

Air Handling Unit eQL

Catalogue July 2012



FlaktWoods

Contents

eQ Family.....	2
Introduction	3
Air handling with technology in the centre.....	4
Fans – the heart of the system.....	5
Highly efficient heat recovery	6
ControlMaster® – control when demands are high	7
A robust casing platform.....	8
Design	9
Unit description.....	10
Dimensions – Quick Selection	26
Quick Selection table	27
Control equipment.....	29
Fan Charts	
LQLR	31
Plenum fan LQLK	39
Description.....	47
Dimensions and Weights.....	56
Index	101

eQ Family

Fläkt Woods offers a full range of Air Handling products covering a wide range of applications and requirements. eQL is a part of the eQ family and is a Air Handling Unit with high air flows.

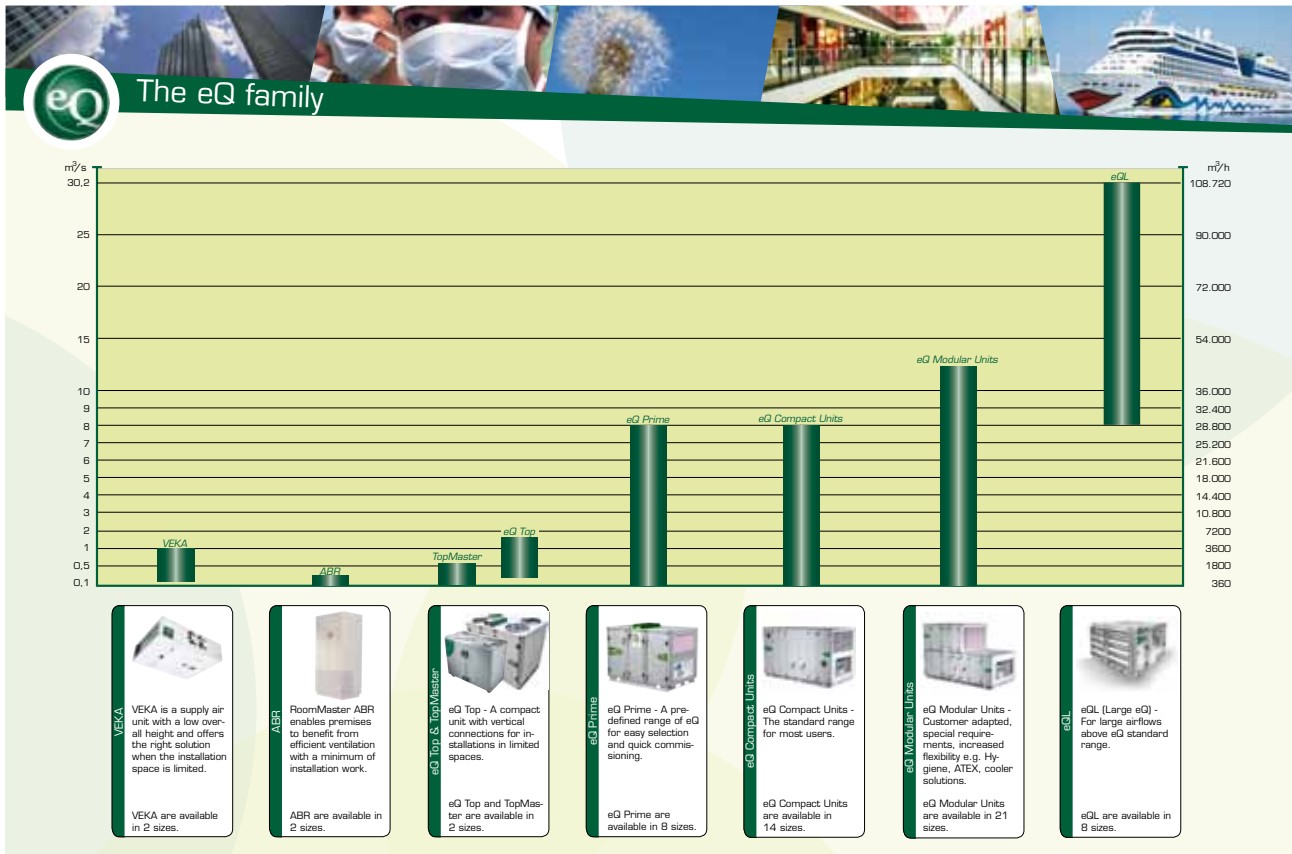

eQL is a air handling unit with high air flows.

eQ is a range of Prime, Compact and Modular units with low energy consumption, and ease of use in focus.

- High efficiency plenum fan.
- Permanent magnet motors.
- Comprehensive range of optimised energy recovery systems to minimize your energy costs and environmental impact.
- Integrated controls packed with features to help you save energy while keeping a high standard of comfort.
- Integrated cooling systems with environmentally friendly latent energy recovery.
- A corrosion protected, well insulated, hygienic and air-tight casing.



Fläkt Woods has extensive knowledge and vast experience. We have produced air handling units since 1937.

The main components are designed and manufactured by Fläkt Woods specifically for our eQL air handling units. We control the quality and the performance. We ensure that the quality and performance are optimized to give best possible performance over the lifetime of the unit.

The air handling units eQL and all components are designed, tested and produced by the Fläkt Woods to applicable standards including ISO 9001 (quality assurance), ISO 14001 and EMAS (environmental management). Technical performance is generally in accordance with CEN standards.



Air handling with technology in the centre

An advanced product selection program makes dimensioning and specifying easier than ever before.

The associated product selection program is an integrated part of the eQL air handling units. It quickly and easily selects the right unit size and type to meet the preferred specifications.

The program gives a complete technical specification with detailed dimensional sketches. Pressure drop, power consumption, efficiency, sound data, SFP-figure and LCC cost calculations are calculated automatically and are presented on screen as well as on a printout. Even a 3D unit drawing can be transferred to AutoCAD.

Laboratory tested components

The Fläkt Woods laboratory is equipped to test the performance of fans, filters, heat recovery units and other components according to applicable standards.

Certification comprises the testing of a standard unit in an independent laboratory chosen by EUROVENT. Measured data must correspond with catalogue data as well as data presented by the product selection program to obtain certification.

The following data is checked:

- Flow, pressure, power consumption
- Sound power to ducts per octave band
- Sound to the surroundings per octave band
- Heating and cooling capacity
- Efficiency of the heat recovery unit
- Pressure drop on the water side

The following is included and tested as a supplement: mechanical strength, heat transfer, filter leakage and sound levels (according to the standard prEN 1886).



The Fläkt Woods laboratory is equipped to test everything from fans and filters to heat recovery units and complete systems.

Fans – the heart of the system

The fan is the heart of the air handling system. As experts in fan design we know how to install fans in air handling units.

The eQL units are equipped with fans manufactured by Fläkt Woods. We offer a wide range of fan models and accessories allowing you to choose the optimal solution for just your installation.

The fans are tested and measured in our pressure chamber to the standard DIN 24166.

Centrifugal fans

The most popular fans are belt driven centrifugal fans with backward curved blades. These fans offer high efficiency and flexible operation. The belt drive means the motor can run synchronously and we can then choose a motor close to the optimal power output.

Centrifugal fans with forward curved blades are the best alternative for small flows as these require very little space.

The belt drive consists of a standard V-belt with appropriate pulleys. Spare parts are readily available and adjustment is easy.

All bearings are designed for a probable average life of at least 22 years at maximum speed and significantly greater at lower speeds. An alternative is a flat

belt drive which gives higher efficiency and a smaller service requirement. The larger bearings give a longer operating life than equivalent V-belt drives. Another advantage of the flat belt drive is that it does not give off any dust.

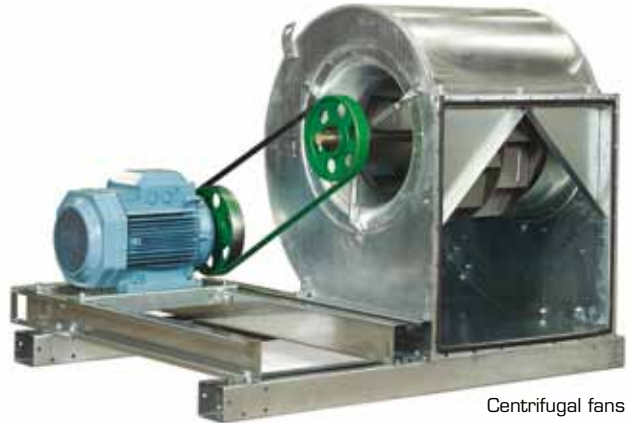

Centrifugal fans

Plug fans

The plug fan has recently become popular. As it is direct driven it requires a minimum of service. It is easy to clean and has a low vibration level.



Low sound level. Fans and units are measured using a sound-level meter in our laboratory.



Centriflow Plus

Many accessories to choose from

Irrespective of which fan you choose you can choose a number of accessories for safety and convenience. A frequency inverter ready connected and installed at the factory is just one example. Flow meter with instrumentation is another good example.

Highly efficient heat recovery



The most suitable alternative is dependent on the conditions in each individual project.

Temperature efficiency is a good measurement to indicate the effectiveness of a heat recovery unit. The greater the efficiency, the more heat recovered. Nevertheless, you should not always aim for maximum efficiency.

Regoterm®

Regoterm® is the heat recovery unit that has the highest temperature efficiency, about 85 % and gives the greatest operating economy savings. It can also recover cold and moisture. A large, effective rotor area gives greater recovery. Laminar air flow gives a low pressure drop and low energy consumption.



Ecoterm®

In installations where the risk of leakage between the supply and exhaust air cannot be tolerated, we can provide the liquid coupled heat exchanger Ecoterm® with a temperature efficiency up to approx. 65 %. As this heat recovery system is based on separate supply and exhaust air units it is only used in our modular eQL unit.

ControlMaster® – control when demands are high

ControlMaster® is a complete integrated control system for Fläkt Woods units. The equipment is supplied installed for complete as well as block divided air handling units.



ControlMaster® is the perfect solution for small systems with basic control equipment as well as for large systems with demands on data communications and an integrated control system. ControlMaster® conforms to eQL:s directives (MD, EMC and LVD) and is CE marked.

Easy selection

ControlMaster® is easy to select using the product selection program. The program automatically selects the control equipment for the unit you have chosen. Shunts are selected for the air heaters or air coolers chosen. Frequency inverters are selected together with the motors, drive systems and fans to give the lowest SFPv-figure. A simple yet effective solution that saves time.

Fast track installation

Not only do you save time during the project design stage but also during installation. ControlMaster® is complete and requires no major on site electrical installation. The control equipment is ready for commissioning as soon as the unit is installed.

A packaged solution

In our workshop great importance is given to test running and the inspection of each control system before delivery, to assure the highest quality.

ControlMaster® is a complete package:

- Air handling unit
- Purpose designed control equipment
- Commissioning of the unit by qualified personnel



A robust casing platform

The double-walled housing elements of aluminum sheet steel, painted galvanized steel or stainless steel plate mounted in a solid frame construction of closed steel profiles and die cast stable corner elements.

When the air handling unit EQL was constructed we put great emphasis on adapting to new opportunities and demands, such as CEN standards and quality assurance in accordance with ISO 9001.

Facilitating service and maintenance was also an important aspect of design.

EQL is an air handling unit range that meets high technology, safety and environmental requirements.

Security on every door

Each door is equipped with a handle and lock as standard. The handle is designed to avoid thermal bridges and leakage.

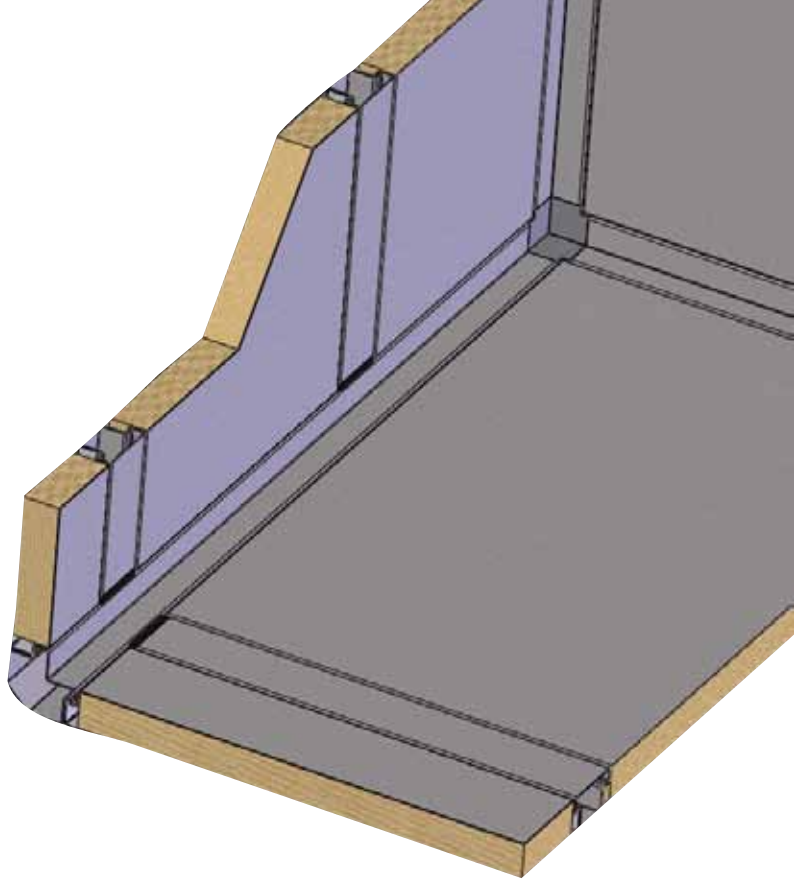

Environmentally safe insulation

The eQL air handling units both use mineral wool as the casing insulation. Mineral wool, which is non-combustible, gives both high-quality acoustic insulation and excellent thermal insulation. The framework is also available with insulation.



Solid frame construction of closed steel profiles and corner of the composite material.



Design

Casing – design and properties

The eQL Air Handling Units

- are modern air handling units. They are designed to meet every conceivable air handling performance requirement and conform to all the pertinent standards in Europe. The units conform to the tightness classes set by CEN and are produced in certificated production facilities both with reference to quality assurance (ISO9001) and workshop environment (ISO14001).
- are based on vast experience. Fläkt Woods has been developing and producing air handling units for more than 50 years. All the main components: dampers, coils, heat exchangers, fans and silencers are made by us.
- offer you flexibility. The large number of standard variants enables us in practice to choose an air handling unit for any space: in the plant room or on the roof of a building.
- cover an air flow range from 0.3m³/s to 38m³/s at pressures up to 2500 Pa.
- offer four heat recovery options including the world leader among rotary heat exchangers.
- are hygienic and are available in a super-hygienic version for clean rooms. The smooth surfaces inside the unit are easy to clean. Simple maintenance and ease of cleaning have been given priority in design of the unit.
- can be supplied as a number of blocks containing an optional number of functional sections. The blocks are joined together by means of internal bolted joints.
- are built on a robust framework of box-section steel. Frame members screwed together with strong corner pieces and clad with 50mm thick panels to create a rigid casing with excellent thermal and sound attenuating characteristics.
- product selection, ordering and production are all computerized. Our product selection computer program helps us offer you products well-suited to your requirements.

Easy configuration of the product selection program ACON

ACON provides clear recommendations and instructions for the unit to meet each standard. Fläkt Woods recommended that the user have good experience of health rated products.

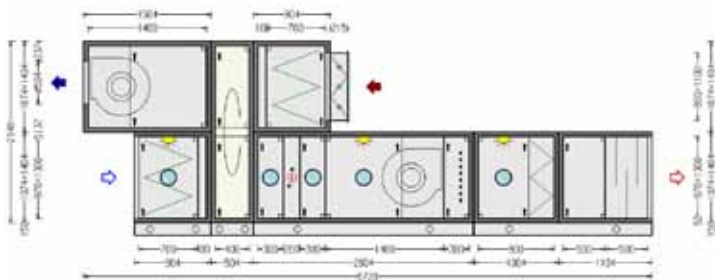

ACON provides all the information and support required for good planning

- Product size
- Audio data
- Efficiency
- LCC
- Delivery
- Dwg and Dxf files can be exported for CAD applications
- Support available for Autodesk i-drop
- Always up to date documentation
- Hygiene Check



Unit description

Casing – design and properties

Technical data

Framework: The framework consists of box-section members made of 1,5 mm thick aluminium-zinc coated sheet steel (size 60-84 1,8 mm).

Corners: rounded corner panels sandwich with two threaded holes in each leg. Frame profiles and corner are screwed together.

Paneler: The panels are of double-skin construction, with 50 mm thick mineral wool insulation sandwiched between sheet steel panels. The density of the insulation is normally standard/m³, but insulation with a density of 55 kg/m³ is also available. The panels are screwed to the frame into a smooth inside and out.

Doors: Doors are fitted with durable rubber seals and are mounted on hinges. The door seals against the frame with a mechanical attached gasket.

Performance: tightness and thermal performance according to CEN Standards.

Outdoor version: the casing is sealed between panels and frame with permanently elastic sealing and provided with hoods and intake sections.

Thermal insulation of the unit: heat transfer coefficient.

Casing thickness	Casing insulation	
	Standard/m ³	55 kg/m ³
0,7 mm	CEN class T3	CEN class T3
0,9 mm	CEN class T3	CEN class T4

Casing tightness

The EU unit conforms to class TB 3 and TB 2 is available on request.

Leakage class

CEN class L2 or L3.

Casing strength

CEN class 1A with 0,7mm panel plate thickness

CEN class 2A with 1,0 mm panel plate thickness

The maximum pressure below and above atmospheric that the casing can withstand without permanent deformation is 2000 Pa.

Sound attenuation in the unit casing: prEN 1886 and ISO 3744-1981

Sheet metall mm	Insulation kg/m ³	Octave bands in accordance with ISO							
		63	125	250	500	1K	2K	4K	8K
0,7	standard	10	10	19	29	31	28	32	33
0,7	55	12	12	22	29	28	26	27	29
0,9	standard	12	12	22	29	28	26	27	29
0,9	55	13	15	23	29	31	29	31	33



Unit description

Casing – design and properties

A unit that meets strict air handling demands

The eQL air handling unit meets the requirements in Accordance with the classification in the CEN standard for air handling units. The components included in the unit are designed and tested in accordance with Swedish and international standards. The eQL air handling unit is produced in 8 sizes covering the air flow range from 8,0 m³/s to 30,2 m³/s. eQ is also available in 21 different sizes with air flow from 0,1 to 12,5 m³/s. Read more about eQ in a separate catalogue. The unit is normally delivered either in multi-function blocks that are easily assembled on site. The unit is available in indoor and outdoor versions, and with a variety of heat recovery alternatives. The air handling unit is certified by EUROVENT. The air handling unit is made by Fläkt Woods which is certified under Quality Standard ISO9001 and environmental standard ISO14001.

- The design of the casing conforms to the provisions of the CEN standard for air handling units.
- Most components are of Fläkt Woods manufacture and the various functions are therefore optimally suited to the eQL unit.
- Sturdy box-section framework contributes to the high strength of the casing.

- The casing panels are of double-skin design with 50 mm thick mineral wool insulation for good thermal and acoustic insulation.
- Mechanically secured cellular rubber sealing strips at the inspection doors reduce the air leakage to a minimum.
- Can be delivered in blocks with one or more functional sections in order to facilitate transport and installation in confined spaces.
- Indoor units can be broken down.
- Totally smooth inside and outside surfaces ensure conformance to strict hygienic demands.
- Wide choice of materials and surface treatment of the unit casing.
- Panels of galvanized sheet steel, and a galvanized frame.
- Panels with internal and external polyester-coated galvanized sheet steel, and a galvanized or stainless steel frame. The external surfaces conform to environmental classM3.
- Panels and frame in stainless steel
- Mineral wool insulation with a density of standard or 55 kg/m³.
- Frame insulation using 140 kg/mv.

Design features

The casing framework consists of box-section frame members joined together sturdy corner pieces. The entire arrangement forms a strong and stable framework.

The panels and inspection doors are of double-skin construction, with 50mm thick mineral wool insulation sandwiched between sheet steel.

The panels can be removed from the unit. In all unit sizes, the inspection doors are hung on adjustable hinges and are equipped with mechanically secured sealing strips. The inspection doors are also available with door locks.

The sandwich construction results in a casing with smooth inside and outside surfaces, which facilitates cleaning and reduces the risk of accumulations of dirt. Since the inside of the unit is completely lined with sheet steel, the risk of fibre entrainment by the air stream is completely eliminated.

The unit is available in an enhanced hygiene version with sealed internal joints. To simplify maintenance and service, many of the unit sections can be fitted with inspection windows.

Framework

The casing is designed for:

- a pressure of 2500 Pa above or below atmospheric
- maximum air temperature of 70 °C.

The framework consists of box-section members made of 1,5 mm thick aluminium-zinc coated sheet steel.

The box-section members are joined together by means of cast aluminium corner pieces. The frame members are normally un-insulated, but can also be supplied with internal insulation. The blocks are joined together by means of internal bolted joints in the corners of the framework.

Double-skin construction of casing panels

The panels are of double-skin construction, with 50 mm thick mineral wool insulation sandwiched between sheet steel panels. The density of the insulation is standard kg/m³, but insulation with a density of 55 kg/m³ is also available. The panels are made of galvanized sheet steel, plastic coated steel or stainless steel.

Unit description

Casing – design and properties

Doors

Doors are fitted with durable rubber seals and are mounted on hinges. All doors fitted with lockable handle.

Thermal insulation of the unit

Heat losses from the casing

The heat transfer coefficient of the unit casing is given in $W/(m^2 \text{ } ^\circ\text{C})$ when the temperature differential between the inside and outside of the casing under steady-state conditions, is $20 \text{ } ^\circ\text{C}$. The size and appearance of the test unit and the test procedure are well defined in the standards. According to CEN standard prEN1886, the heat transfer coefficient $U=W/(m^2 \text{ } ^\circ\text{C})$ of the unit casing is classified in accordance with the following table.

Class T1: $0 < U > 0.5$

T2: $0.5 < U > 1.0$

T3: $1.0 < U > 1.4$ (50 kg/m^3)

T4: $1.4 < U > 2.0$ (140 kg/m^3)

T5: No requirements

The eQL unit conforms to class T4

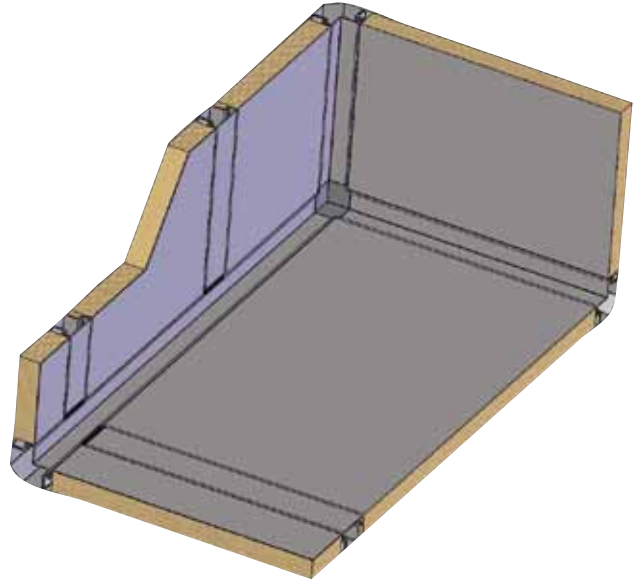

Anti-condensation insulation of the casing

The insulation factor k_b (dimensionless, cold bridge factor) is defined by the following formula:

$k_b = (t_s - t_i) / (t_e - t_i)$ where

t_i = Average temperature of the air in the unit casing

t_e = Average ambient temperature

t_s = Lowest external surface temperature of the unit casing

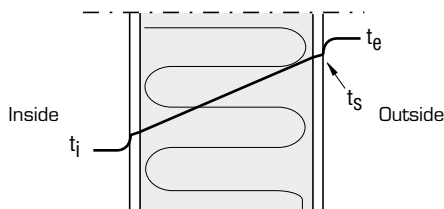

The insulation factor is a value between zero (0) and one (1). The wall elements have an insulation factor which assumes values close one (1), although the values are lower at certain points on the framework.

According to CEN standard prEN 1886, the insulation factor is classified in accordance with the following table.

Class TB 1: $0.75 < k_b > 1.00$

TB 2: $0.60 < k_b > 0.75$

TB 3: $0.45 < k_b > 0.60$

TB 4: $0.30 < k_b > 0.45$

TB 5: No requirements

The lowest value of the insulation factor measured on the outside of the casing determines the insulation class to which the unit casing is assigned.

The eQL unit conforms to class TB

The insulation factor can be used as a guide to whether there is risk of condensation occurring. The lower the value of k_b , the higher the likelihood of condensation occurring on parts of the unit casing in which the air temperature is low. In order to obtain class TB 2/3 for unit divided in blocks an internal insulation of the joint should be ordered.

Unit description

Casing – design and properties

Casing tightness

CEN-standard prEN 1886 classifies leakage rates for air handling units as follows.

Leakage class	Suction -400 Pa Leakage flow max l/s	Pressure +700 Pa Leakage flow m ² max l/s	Highest rec. m ² filter class
L3	1,32	1,90	G1-F7
L2	0,44	0,63	F8-F9
L1	0,15	0,22	over F9

The leakage flow rate for a unit only subjected to suction must not exceed the above tabulated figures at -400Pa. The leakage flow rate for a unit only subjected to pressure must not exceed the above tabulated figures at 700 Pa.

eQL-meets leakage class L3 or L2.

Corrosion resistance/environmental class

Corrosion resistance class BSK99	Panel	Frame work
C3	Galvanized sheet steel Z275	Galvanized sheet steel Z275
C4	Polyester coated galvanized sheet steel	Aluzinc
C5- (I+M)	Stainless steel plate	Stainless steel plate

eQL-meets corrosion resistance class C4 or C5.

Corrosion resistance/environmental class
CEN-standard prEN 1886 classifies casing strength as follows:

Casing class	Max deflection per meter	Meets max. fan pressure
D3	over 10 mm	yes
D2	10 mm	yes
D1	4 mm	yes

Definition

To meet class D1, D2 or D3 the casing shall both not exceed the prescribed deflection and be able to withstand the maximum pressure the fan is capable of without plastic deflection.

The maximum pressure below and above atmospheric that the casing can withstand without permanent deformation is 2500 Pa.

Official test

The classifications of the eQL unit casing have been verified by measurements at the independent RWTUV laboratory in Germany.

Sound attenuation in the unit casing

The casing sound reduction is given for a closed system, measured in accordance with EN1886. The casing offers a 26 dB (A) reduction.

Sound attenuation of the components

The casing sound reduction is given for a closed system, measured in accordance with EN1886.

Unit description

Casing – design and properties

Outdoor version

The outdoor version of the unit is basically the same as the indoor version, and the technical specifications are the same.

The outside of the casing is sealed between panels and Frame with permanently elastic sealing compound to prevent moisture from entering the unit.

Intake sections with grilles designed for an effective barrier against rain and snow are available. The unit is equipped with a curved roof to ensure good water run-off. The roof projects beyond the edge of the unit casing and has a turned-down edge.

The unit should preferably be mounted on longitudinal beams or on supports spaced a maximum of 1,5 m apart. The electrical cubicle and pipe work package should be installed in a warm and easily accessible area indoors.

Hygiene version

Even in its basic version, the eQL unit meets very strict hygienic demands. In each unit module the sides of the casing are perfectly smooth, i.e. there are no level differences between panel surfaces and the closed frame sections. Inspection doors of ample size make it easy to wipe dry the inside surfaces of the unit.

The unit has no threshold what ever. To ensure good drainage of flushing water, it is advisable to install the unit with a slope of about 2° towards the inspection side. This can be done, for instance, by means of a base frame and adjustable feet.

The hygiene version of the casing is sealed internally between panels and frame to allow for washing and to minimize dust pockets.

For collecting the flushing water, the unit can be equipped with a LQWZ-02 drain trough by the inspection doors.

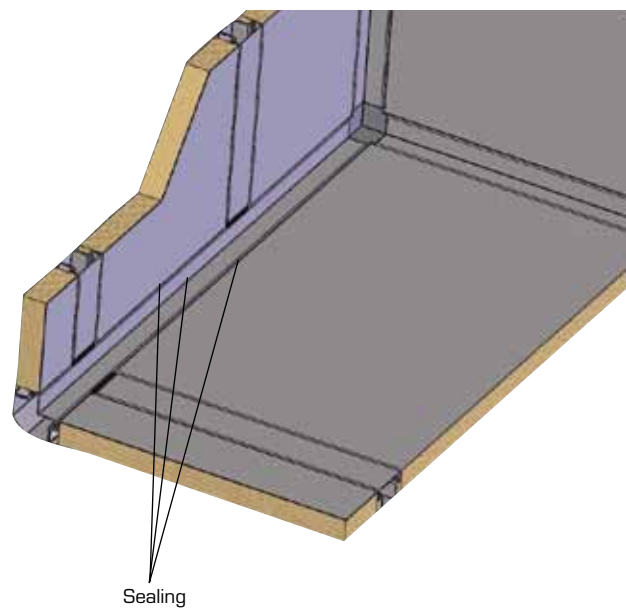

Unit description

Damper sections

Dampers



Counter-rotating damper blades of double-skin design, journalled in bearings made of acetate plastic. Smaller dampers with gearwheels and larger dampers with linkage mechanism.
 Max. permissible pressure differential: 1000 Pa when the damper is closed.
 Material: Galvanized sheet steel / stainless sheet steel.
 Tightness class: CEN 3, CEN 4 (T4/T5).

End connection frame

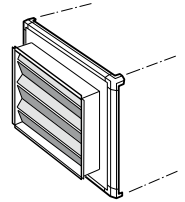
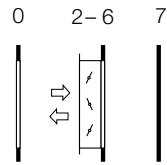

Connection frame section

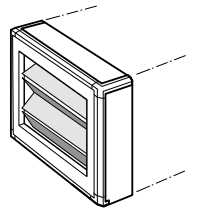
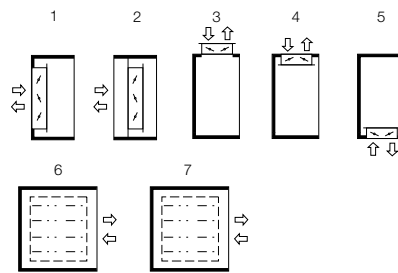

Mixing section

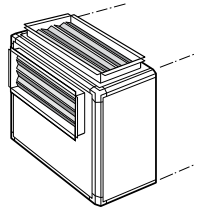
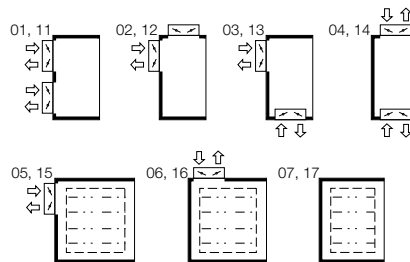

Mixing and extract air section

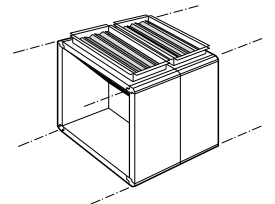
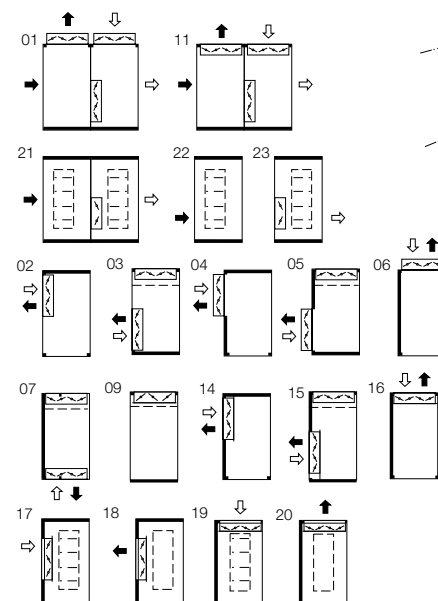

Unit description

Filter sections

Filter, short

Filter cassettes, cleanable or disposable, G2 to G4.



Filter, medium long

Filter cassettes, basic bag filter, G3 – F5 or fine compact filter F6 to F9. For horizontal or downward vertical airflow.

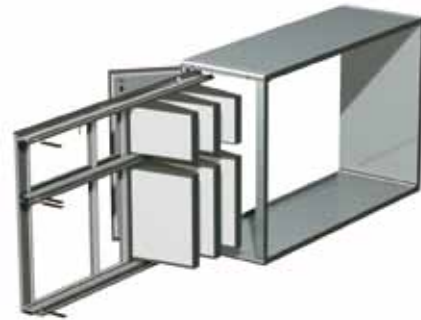

Filter, long

Filter cassettes, basic and fine filter. G3 – F9.
Can also be fitted with class G3 pre-filter.
For horizontal air direction, inlet/outlet.
For horizontal air direction, inlet, vertical outlet.
For vertical inlet, horizontal outlet.

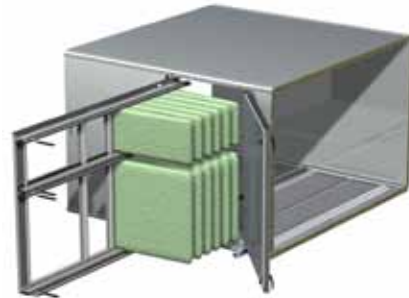

Carbon filter

Filter with activated carbon in cylinders or cassettes.
For horizontal airflow.



Absolute filter

Absolute filter of filter classes H10 to H14 fixed in a mounting frame of patent-pending design.
The filter section shall be ordered together with an inspection section to be fitted down stream of the filter.



Unit description

Air heaters/Air coolers

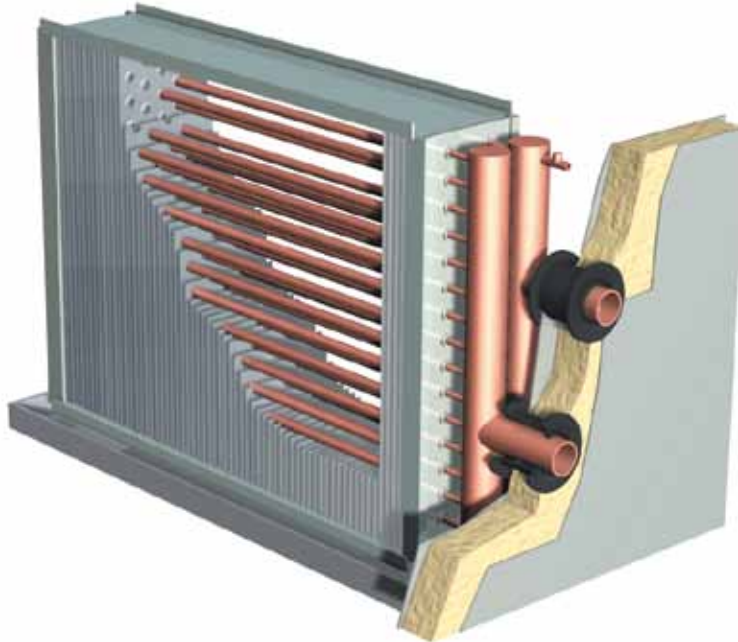

Air heater for hot water
Heat exchanger with aluminium or copper fins and copper tubes.

Material: Galvanized sheet steel; stainless sheet steel.
Tubes / fins: Cu/Al, Cu/Cu, Cu/CuSn, Corroplast.

Max. permissible operating pressure: 10/16 bar.
Max. permissible water temperature: 190/100 °C.

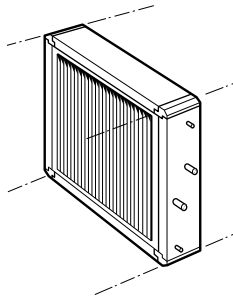

Air heater, electric
Electric air heater of high and low temperature type.

Max. permissible surface temperature: 90 °C (low temp. version.)

Material: Galvanized sheet steel; stainless sheet steel.
Voltage: 3 x 230 / 3 x 400 / 3 x 415V.

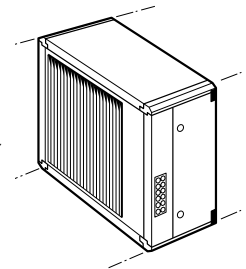

Air heater, steam
Heat exchanger with aluminium or copper fins and copper tubes.

Material: Galvanized sheet steel; stainless sheet steel.
Tubes / fins: Cu/Al, Cu/Cu, Fe/Al.

Max. permissible operating pressure: 10 bar.
Max. permissible water temperature: 185 °C.

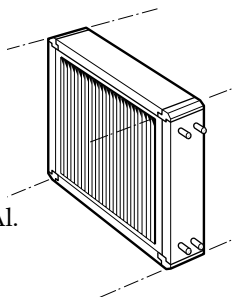

Air cooler for chilled water or direct expansion

Heat exchanger with aluminium or copper fins and copper tubes. Equipped with sloping drain tray made of stainless sheet steel.

If condensation is likely to form and the air velocity exceeds 3 m/s, the coil must be equipped with a droplet eliminator.

Material: Galvanized sheet steel; stainless sheet steel.
Tubes / fins: Cu/Al, Cu/Cu, Cu/CuSn, Corroplast.

Options:

- fin pitch 2, 2.5 and 3 mm
- max. face area
- with drawable droplet eliminator
- with drawable drain tray

Max. permissible operating pressure: 16 bar (14 for DX).

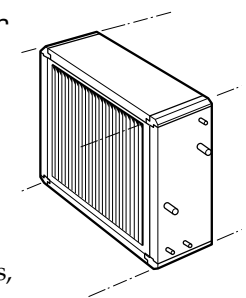

Unit description

Humidifiers/Centrifugal fans/Plug fans

Humidifier (evaporative)

Unit section for steam humidifier

Evaporative humidifier with humidifier fills made of Aluminium or glass fibre.

Once-through water: glass fibre only

Inlet conn: DN15 male thread, outlet conn. DN32 female thread.

Unit section for steam humidifier consists of an empty Section with drain tray made of stainless steel, and a support for installation of steam distribution lances.

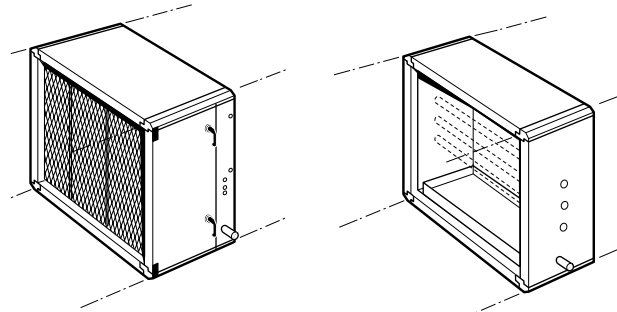

Belt-driven centrifugal fans

Fans with spiral casing and forward or backward curved blades, i.e. type F or B impeller. Type F impeller for the smaller size units if power efficiency isn't of vital importance and type B impeller if high power efficiency is a primary objective.

Material: Galvanized sheet steel/stainless sheet steel (in the stainless version, the fan casing, impeller and belt guard are epoxy-painted).

Options

- with airflow measurement
- spark-proof fans
- with bimetallic/thermist or type thermal relays in the motor
- belt drive with V-belts / flat belt
- rubber / steel spring anti-vibration mountings.

Inlet

- unit cross section / backside / roof / bottom.

Discharge

- forward / upwards / downwards.

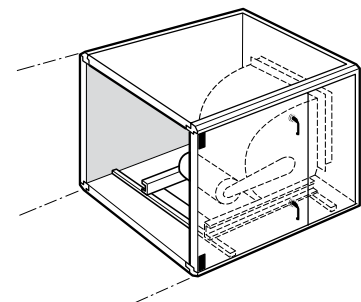

Unit description

Humidifiers/Centrifugal fans/Plug fans

Direct-driven plug fans

Plug fans are especially well-suited for hygienic applications. The lack of fan casing makes the fan simple to clean. Since the fan can be balanced for low vibration levels, it is well-suited for applications in which vibration-free operation is required.

Material

- galvanized sheet, steel/stainless sheet steel
(fan stand and impeller are epoxy-painted)

Options

- with centrifugal diffuser (improves fan efficiency)
- with airflow measurement
- with bimetallic/thermistor type thermal relays in the motor
- rubber/steel spring anti-vibration mountings.

Inlet

- unit cross section

Discharger

- forward/upwards/towards backside

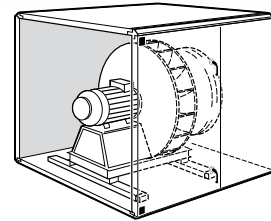

Angle Section/Empty Section/Silencer

Empty section

For inspection and maintenance work or for connection to ducts.

Material: Normal casing material options

Inspection door: with/without

Duct connection alternative: At the top or rear side

Drain tray: With/without.

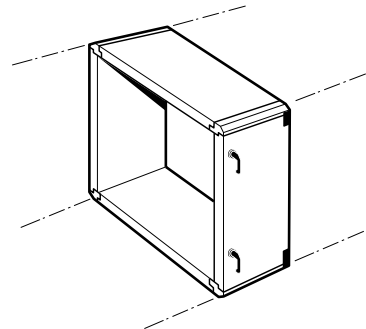

Silencer

Absorption silencer with baffle elements. The baffle elements contain incombustible, sound absorbing mineral wool slabs protected by a woven outer layer which prevents entrainment of wool fibres by the airflow. Baffle elements are available in versions for dry or wet cleaning.

Material: Galvanized sheet steel/stainless sheet steel

Inspection door: with/without

With drawable sound baffles: yes/no

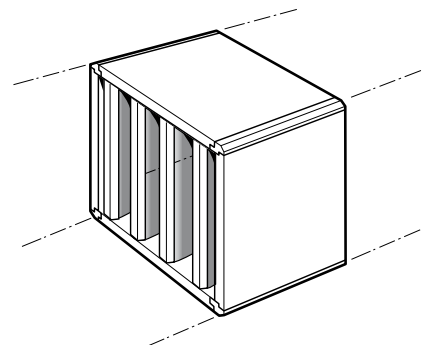

Unit description

Heat Recovery

Rotary heat exchanger REGOTERM

The rotary heat exchanger is used for recovering and transferring heat or cooling energy and, if required, moisture from the extract air to the supply air. The REGOTERM system is especially beneficial for installations, where high temperature and humidification efficiency is desirable.

Material: Galvanized / stainless sheet steel

Rotor: Aluminium

Rotor type: One-piece / sectorised rotor
Non-hygroscopic / hygroscopic
Reinforced edges, without / with
Foil spacing: normal / wider



ECOTERM

Liquid-coupled heat exchangers

The heat exchanger coils, one for supply air and one for extract air, consist of copper tubes and aluminium fins. The extract air coil has a sloping drip tray made of stainless steel. If condensation is likely to form and the air velocity exceeds 3 m/s, the coil must be equipped with a droplet eliminator.

Temperature efficiency up to 70 %.

Application: Heating coil / cooling coil.

Material: galvanized sheet steel / stainless sheet steel
Tubes / fins: Cu / Al, Cu / Cu, Cu / tinned Cu, Corropaint.

Fin pitch: 2 mm / 4 mm

Circuit length: short or long

Max. perm. operating pressure: 16 Bar

Max. perm. operating temp.: 70 °C (inlet temperature in the extract air path)

Variants: – max. face area
– with drawable droplet eliminator

Designed for horizontal airflow direction.

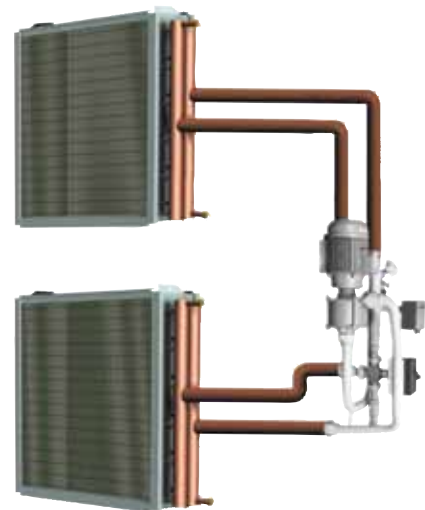

Unit description

Heat Recovery

ECONET®

Liquid-coupled coils

For heat recovery, heating and cooling

The ECONET functional section is unique in that it can completely eliminate the need for additional heating coils and cooling coils. The extra energy necessary for heating/cooling is supplied directly in the energy recovery circuit. High-efficiency heat exchangers make it possible to utilize low-grade heat, often in the form of waste heat. The difference between the supply air temperature desired and the temperature of the incoming medium can also be kept very low.

The two heat exchangers, one for supply air and one for extract air, consist of copper tubes and aluminium fins. Both heat exchangers have sloping drain trays made of stainless steel. If condensation is likely to form on the coil surface and the air velocity exceeds 3m/s, the coil must be equipped with a droplet eliminator.

Temperature efficiency up to 70 %.

Besides the two heat exchangers, the product also includes the following:

– pump unit (1)

The unit consists of a pump, piping components and necessary sensors. The pump is a multi-stage centrifugal pump driven by a controllable variable-speed motor.

The pump casing, impeller and end pieces are made of stainless steel.

– control unit (2)

The unit consists of a controller that controls the liquid circuit. The controller has software specially developed for optimally utilizing the heat exchangers under any conditions that might arise.

Alarm functions that include anti-frost protection are included.

– Frequency inverter for controlling the speed of the pump motor.

Initial adjustment and commissioning at the installation site are always included in the ECONET package.



Unit description

Accessories

Lifting wires

The lifting wires can be secured against the lower corner pieces of the unit.
Max. permissible load with 4 lifting wires: 3000 kg.

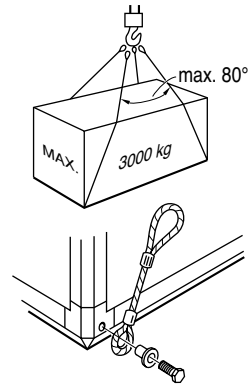

Lifting spreaders

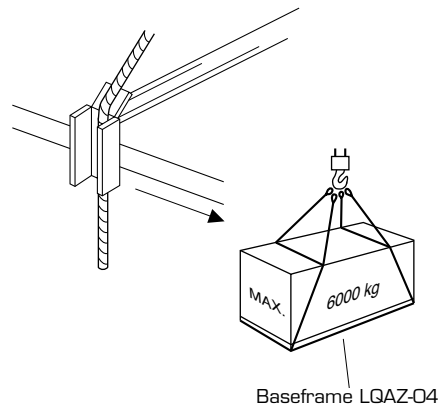

Lifting tubes

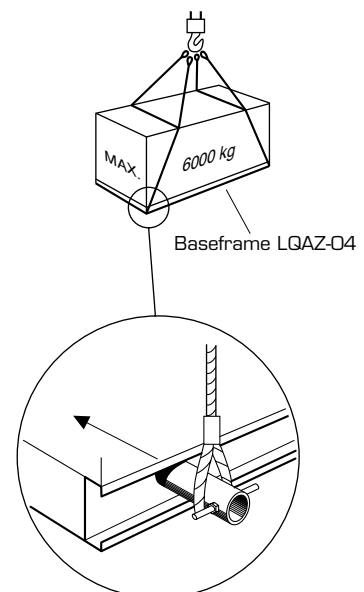

Unit description

Accessories

Inspection Window

With one or two Plexiglas panes.

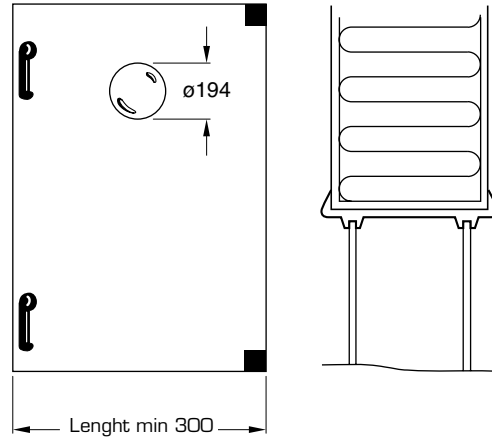

Base frame

A very stable and torsionally rigid base frame, either for the whole unit or for one or several blocks. The frame of the air handling unit is secured to the base frame by means of brackets. The length and width of the base frame shall be selected to suit the size of the air handling unit and the combination of functional sections.

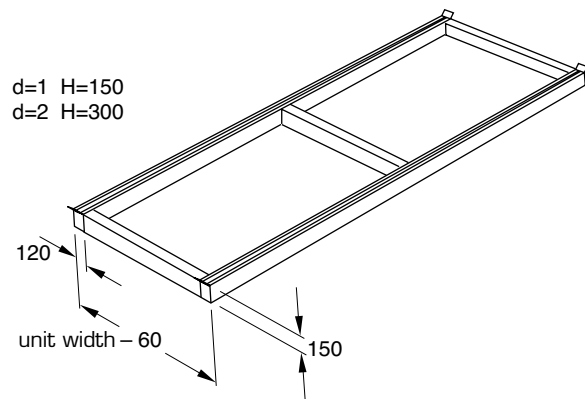

Water trap

Used if the pressure in the unit is sub-atmospheric. Must not be used if the pressure inside the unit is above atmospheric.

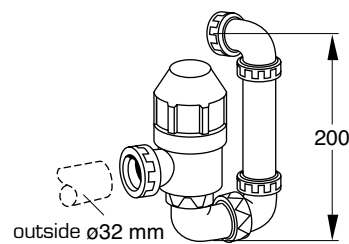

Unit description

Accessories

Lighting fixtures
60 W bulb

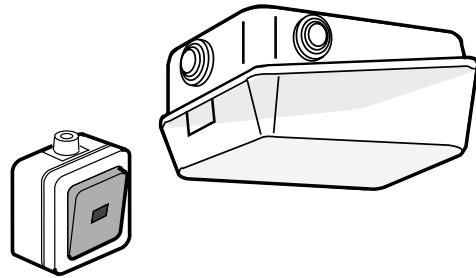

Manometer

For measuring the pressure drop across the filter.

Measurement range: up to 400 Pa

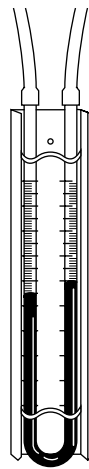

Measurement range: up to 500 Pa.

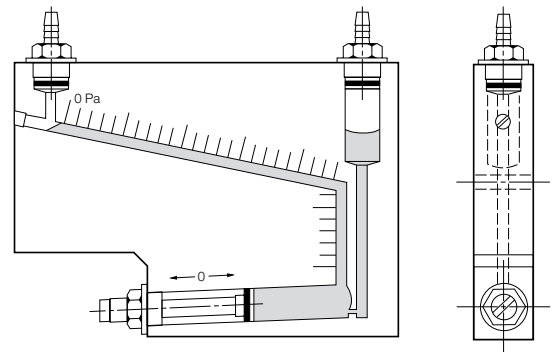

Differential pressure gauge

(Make: Dwyer Magnahelic)

Flush-mounted in the inspection door.

Measurement range: up to 300 Pa.

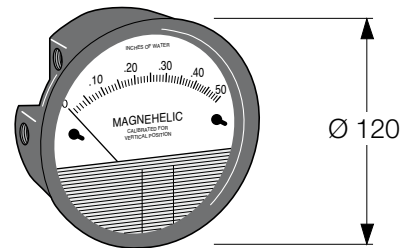

Filter monitor

Electronic remote monitor – indicates if pressure drop across filters exceeds the preset limit (40 – 400 Pa).

Assembly kit and connection parts are included.

Many other accessories are also available, such as duct connection accessories of various design, coil flanges, door locks, etc. For further particulars get in touch with your nearest Fläkt Woods representative.

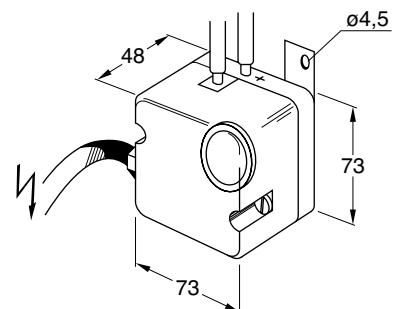

Unit description

Accessories

Connection accessories on the air side

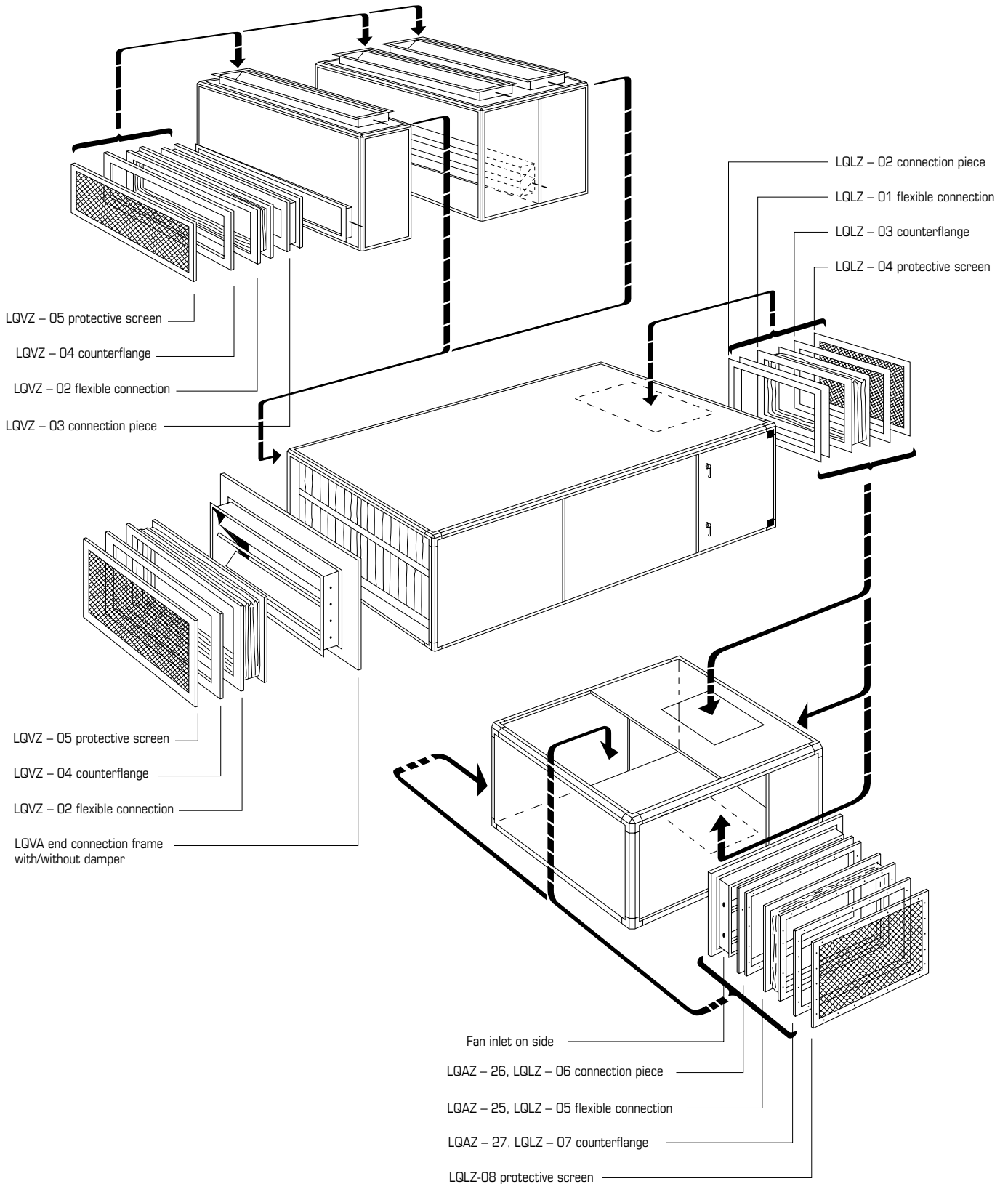

Dimensions – Quick Selection

Using the quick selection tables

- A. Starting on the left hand side, find the column with an appropriate air velocity and then find a suitable unit size for the airflow rate you have.
- B. The width and height of the unit are found in the columns further to the right. Add to 150mm in height if a base frame shall be included
- C. Follow the columns to the right and not the individual lengths and weights of the individual sections needed in the unit. Don't forget inspection sections.
- D. eQL units can be assembled in a number of multi function blocks with a block length to suit conditions on site. For each block, the overall length is determined by summing the individual section lengths together with the casing length.

E. Details of duct connections are to be found on the following page to the right. Outdoor functions such as intake sections are to be found on the last page.

Basic rules for multi-function blocks:







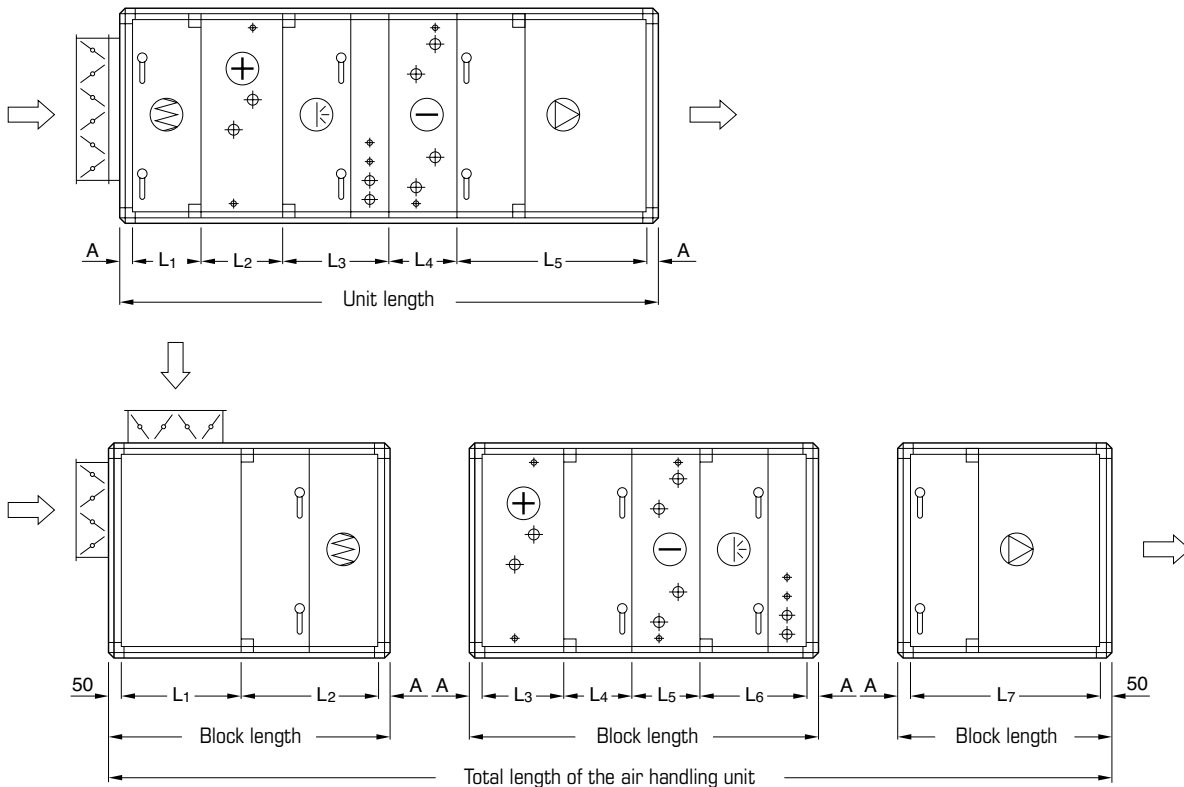

- 1. Check that the length does not exceed the maximum given in the table below.
- 2. Rotary and plate heat exchangers, Coolers and some other items are always delivered as individual blocks.
- 3. Make sure that it is possible to access the block joints during site assembly so that the jointing bolts can be fitted.

Size	Max. block length
60, 62, 71, 80	6000
64, 73, 82, 84	3000

Example:



Quick selection table







Unit size	Air flow rate m ³ /s (m ³ /h)					Filter modules			Unit Cross section	
	Maximum	Cooling coil (LQNN) face velocity, m/s			LQHN	Filter cassettes	Cassette arrangement	Filter face area m ²	Unit width, mm Normal Rotor	Unit height mm
		2,0 m/s	2,5 m/s	3,0 m/s	2,5 m/s					
60	13 47952	6.66 23976	8.33 29970	9.99 35964	- -	9		3.24	2050 3400	2050
62	18 63504	8.82 31752	11.03 39690	13.23 47628	- -	12		4.32	2650 3660	2050
64	22 79056	10.98 39528	13.73 49410	16.47 59292	- -	15		5.4	3250 4000	2050
71	20 73030	10.14 36515	12.68 45644	15.21 54772	- -	14		5.04	2650 4000	2350
73	25 90914	12.63 45457	15.78 56822	18.94 68186	- -	17.5		6.3	3250 4500	2350
80	24 84672	11.76 42336	14.70 52920	17.64 63504	- -	16		5.76	2650 4500	2650
82	29 105408	14.64 52704	18.30 65880	21.96 79056	- -	20		7.2	3250 4500	2650
84	36 131328	18.24 65664	22.80 82080	27.36 98496	- -	24		8.64	4000 4900	2650



Funktionsdelarnas – Längd, mm. Vikt, kg.

Unit size	Centrifugal fan			Plenum fan				Intake damper	Connection section			Mixing section			Mixing and Exhaust		
	Fan size			Fan size					end	top	side	end	top	side	end	top	side
	1	2	3	1	2	3	4										
60	2000 680	2250 790	2450 1030	1450 420	1550 433	1650 468	- -	240 80	350 195	1000 320	1400 400	1000 330	1000 330	1400 415	2000 470	1000 235	1000 230
62	1800 800	1800 950	2850 1240	1450 455	1550 468	1350 669	- -	240 115	350 245	1000 390	1600 520	1000 400	1000 400	1600 535	2000 550	1000 265	1000 260
64	1800 1000	2050 1030	2250 1260	1650 531	1350 699	1450 710	1550 737	240 135	350 280	1000 430	1800 630	1000 450	1800 450	1000 640	2000 620	1000 305	1000 300
71	1800 990	2900 1350	3100 1450	1650 520	1350 687	- -	- -	240 145	350 285	1000 435	1600 590	1000 440	1000 440	1600 600	2000 720	1000 285	1000 285
73	2050 1240	2250 1340	2500 1550	1650 649	1350 718	1450 729	1550 756	240 180	350 335	1000 495	1800 720	1000 505	1000 505	1800 725	2000 810	1000 320	1000 315
80	1800 1030	2900 1390	3100 1500	1650 538	1350 706	- -	- -	240 175	350 320	1200 530	1600 640	1200 535	1200 535	1600 655	2400 770	1200 360	1200 350
82	2050 1230	2250 1400	2500 1600	1350 737	1450 748	1550 775	- -	240 205	350 365	1200 595	1800 770	1200 600	1200 600	1800 790	2400 870	1200 410	1200 400
84	2250 1500	2500 1750	2900 2200	1450 792	1550 819	1650 895	- -	240 255	350 435	1200 685	2050 945	1200 700	1200 700	2050 890	2400 990	1200 460	1200 450

Quick selection table

Functional sections - Length, mm, Weight, kg.

Unit size	Outdoor Unit			Filter						Battery		
	Intake 	Outlet 	Mix 	Panel filters	Short bag filters	Long bag filters	Filter with prefilter	Carbon filter	Absolute filter	Air heater for hot water 	Air heater electric 	Air coolers 
60	350 190	350 160	1200 350	650 175	- -	750 195	750 220	650 620	1800 420	350 240	500 305	650 510
62	350 245	350 205	1200 430	650 205	- -	750 230	750 260	650 780	1800 500	350 290	500 385	650 640
64	350 285	350 235	1200 485	650 250	- -	750 260	750 300	650 960	1800 600	350 330	500 465	650 770
71	350 285	350 240	1200 480	650 235	- -	750 255	750 295	650 900	1800 600	350 340	500 440	650 750
73	350 345	350 290	1200 560	650 275	- -	750 290	750 335	650 1100	1800 700	350 395	500 530	650 900
80	350 325	350 275	1400 580	650 250	- -	750 270	750 310	650 1015	1800 650	350 380	500 490	650 830
82	350 385	350 320	1400 660	650 290	- -	750 305	750 350	650 1255	1800 700	350 435	- -	650 -
84	350 460	350 385	1400 770	650 330	- -	750 350	750 410	650 1490	1800 850	350 510	- -	650 -

Unit size	Heat recovery							Humidifier Evaporative
	Regoterm 	Econet 	Ecoterm 	Length				
				500	900	1300	1700	
60	450 1350	750 670	650 580	- 230	- 310	- 380	- 545	1000 333
62	450 1450	750 850	650 730	- 280	- 370	- 460	- 660	1000 400
64	450 1700	750 1030	650 880	- 325	- 430	- 535	- 770	1000 444
71	450 1700	750 1000	650 860	- 310	- 410	- 510	- 735	1000 433
73	450 2025	750 1200	650 1030	- 360	- 480	- 600	- 860	1000 500
80	450 2025	750 1120	650 960	- 340	- 450	- 560	- 810	1000 478
82	450 2025	750 1360	650 1160	- 400	- 525	- 660	- 940	1000 567
84	450 2750	750 1620	650 1400	- 460	- 610	- 760	- 1090	1000 656

Control equipment

ControlMaster®, Description, General



ControlMaster for eQL

ControlMaster is a complete, integrated control equipment package for air handling units from Flakt Woods. The equipment is supplied incorporated into both one piece air handling units and units divided into blocks. ControlMaster is a perfect solution for both small ventilation systems with simple control equipment needs, and for large ventilation systems that require data Communication and integrated control systems. ControlMaster complies with EU Directives (MD, EMC and LVD), and is CE marked.

Simple to engineer

ControlMaster is simple to engineer using the ACON product selection software. The same computer program can be used for both the air handling unit and for ControlMaster, and automatically sizes the control equipment to match the air handling unit selected. The pipe work packages are sized for the air heaters or air coolers selected. Frequency inverters are sized together with motors, drive systems and fans for the lowest possible SFP_v.

Quick installation

Besides saving time when you engineer the equipment, You also in time when you install it. ControlMaster is a complete control package integrated into the air handling unit and doesn't require any major electrical installation work at the building site. The control equipment is installed and operational on the same day the air handling unit is installed, ready to commission!

Pre-delivery inspection

In our workshop, we place utmost importance on trial testing and checking the performance of every set of control equipment before it is delivered, to ensure the highest quality.

High quality

Installing control equipment to achieve top quality in an air handling unit requires experience and know-how about how the controls will affect the distribution of air to the premises. ControlMaster is an air handling unit control equipment package for practically every conceivable ventilation system.

Simplicity

ControlMaster is all that is needed for the small ventilation system with one single or just a few air handling units. There's no need to engage a control installation engineer.



Control equipment

Description, General

Clear lines of responsibility

Fläkt Woods supplies a ready-to-use package with warranty and client support for the air handling unit as well as the control equipment. ControlMaster is a total solution for which full responsibility is assumed by one partner up on whom you can rely trust.

Supply options

ControlMaster for the eQL air handling units is supplied incorporated into the air handling unit or in a cubicle for wall mounting.

Built-in controls in the eQL air handling unit

The eQL air handling unit can be supplied with a built-in control system, tested and configured from the factory. To minimize the time required for installation and to reduce the need for a qualified electrician, many of the functions and field components are supplied with quick fit connectors, where this is possible. The runs of external cables are then protected by galvanized steel conduits or protective tubes made of plastic.

eQL unit can be supplied with an integrated control system that is tested and configured at the factory. To reduce installation time and reduce the need for qualified electricians, many functions and field components are delivered with quick-fit connectors where it is possible.



A typical quick-fit connection for a damper motor.

Description, Electrical Design

The standard electrical equipment is supplied for a 400V, 3-phase, 50Hz, 5-wire system. For Norway: 230V, 3-phase, 50Hz, 4-wire system



The equipment cubicle contains the following components wherever applicable:

- Main switch
- Automatic circuit breaker for control voltage
- Contactors for fans and pumps
- Transformer for 24VAC
- Motor protection switch with thermal and magnetic tripping
- Operating mode selector switch
- Time switch with 24-hour / weekly function with running reserve (included in the controller)
- Terminal blocks for sensors and actuators inside and outside the air handling unit
- Terminal blocks for external group alarm
- Terminal blocks for extended operation
- Documentation
- Drawing pocket
- List of fuse groups

Testing

Each cubicle is subjected to isolation and functional testing prior to delivery. As many parameters as possible are also preset.

Environmental demands

Operating temperature : 0 – 50 °C, max. permissible humidity: < 85 % RF.

The equipment cubicle can be equipped with a heater if the ambient temperature is likely to drop below 0 °C. Please specify this when ordering.

Power supply

The electrical cubicle is available for the supply voltages listed below. An external safety isolating switch must be incorporated into the power supply cable.
230 ±10 % VAC, 3-phase (Norway)
400 ±10 % VAC, 3-phase.

Standards

The cubicle with control equipment complies with the following standards and regulations:
Machinery Directive 98 / 37 / EEC, Electrical Equipment In Machinery, EN60204-1.
EMC Directive 89 / 336 / EEC, EN61800-3 (emissions) EN61000-6-3:2001 and immunity EN61000-6-2:2001
Low Voltage Directive 72 / 23 / EEC[DF2], (EN50178).

Electrical connections

Electrical wiring is run via a flange in the top panel of the air handling unit. If electric air heaters and COOLERS that consume more than 25A are included in the ventilation system, an extra electrical supply must be added for these components (see Cooler catalogue).

Fan Charts

LQLR - Description

LQLR-60-1 (10)

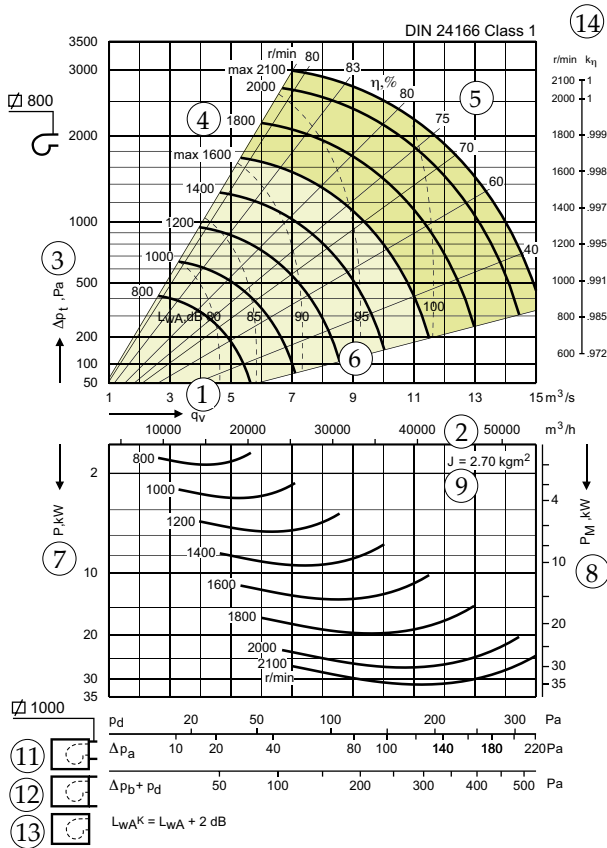

Bearing losses are included in the fan's power demand and affect efficiency

In fan charts, the fan's power demand is defined as the power demand at the fan shaft, which means that its bearing losses are included. The efficiency figures shown on the chart are valid for maximum speed, and are a few percentage points lower than they would be if the bearing losses were ignored. As the speed drops, the fan power falls in proportion to the third power of the speed, while the bearing losses fall only linearly proportionally to the speed. This means that, at lower speeds, the bearing losses become a higher proportion of the total losses while the efficiency becomes correspondingly lower.

Fan charts for fans with backward-curved impellers include a scale for k_η which shows the drop in efficiency at lower speeds.

The scale provides high accuracy of determination of k_η over the normal working range, where the fan's power demand at a given speed is largely independent of the air flow.

The eQL fan charts on the pages that follow are applicable to air with a density of 1.2 kg/m^3 .

- ① = Air flow, m^3/s (x-axel)
- ② = Air flow, m^3/h (x-axel)
- ③ = Total pressure rise, Δp_t Pa (y-axel)
- ④ = Fan speed, r/min
- ⑤ = Fan efficiency η , %
- ⑥ = Sound power level L_{wA} (dB), (dotted)
- ⑦ = Fan shaft power, P (kW)
- ⑧ = Min. recommended motor rating for direct on-line starting, P_M (kW)
- ⑨ = Mass moment of inertia J (kg m^2)
- ⑩ = Unit size and fan size
- ⑪ = Pressure losses to the standardized outlet duct, Δp_a (Pa)
- ⑫ = Pressure losses through distributor section, $\Delta p_b + p_d$ (Pa)
- ⑬ = $L_{wA}^K = L_{wA} + 2$ dB
- ⑭ = Correction factor for efficiency, k_η

- = Recommended working range of the fan.
- = Reduced air flow operation is allowable in the light blue area.
- = Working range for reinforced fan.

Fan Charts

LQLR-60-1

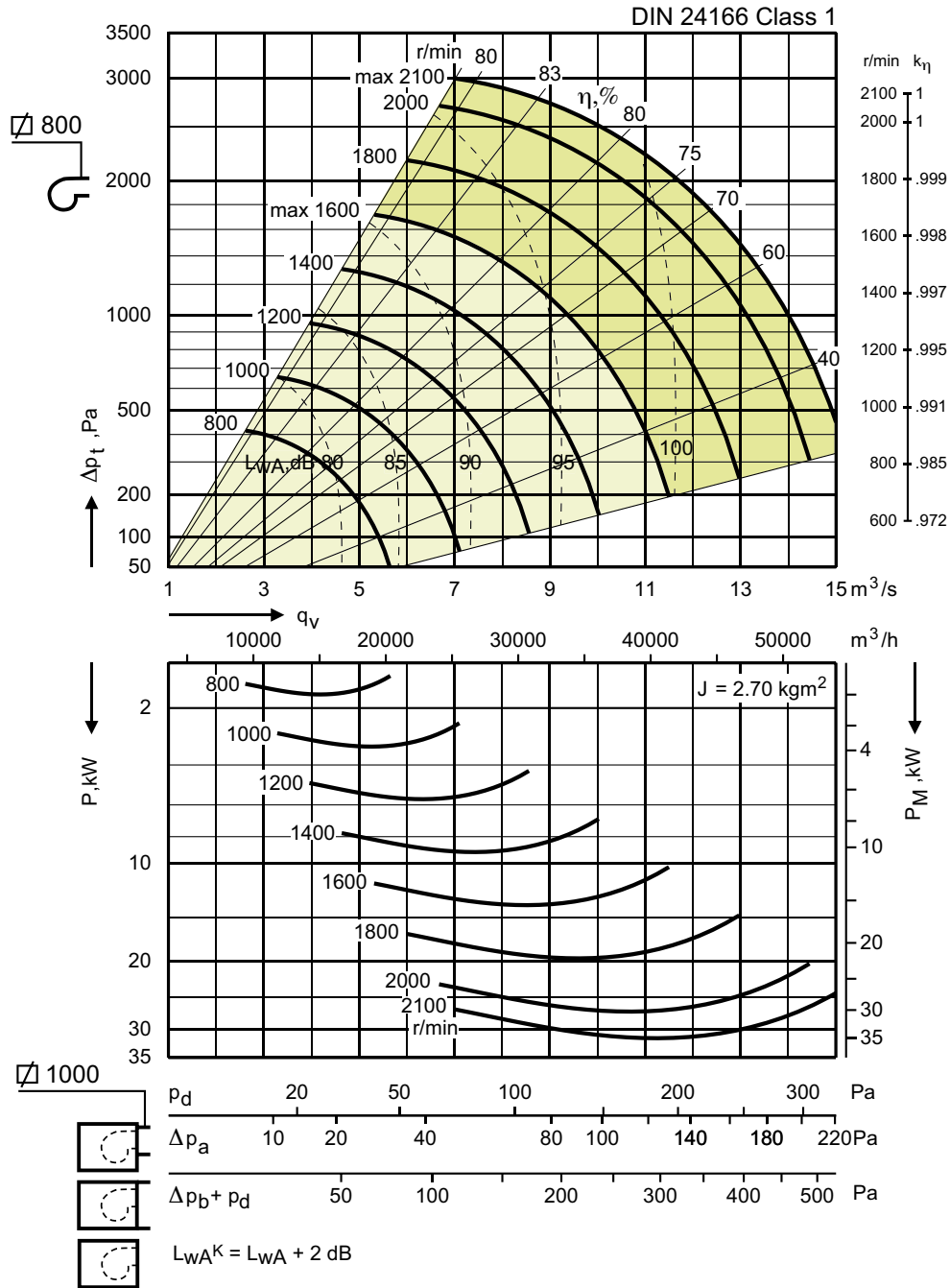

For embedded losses see the product selection tool ACON

Fan Charts

LQLR-60-2/62-1

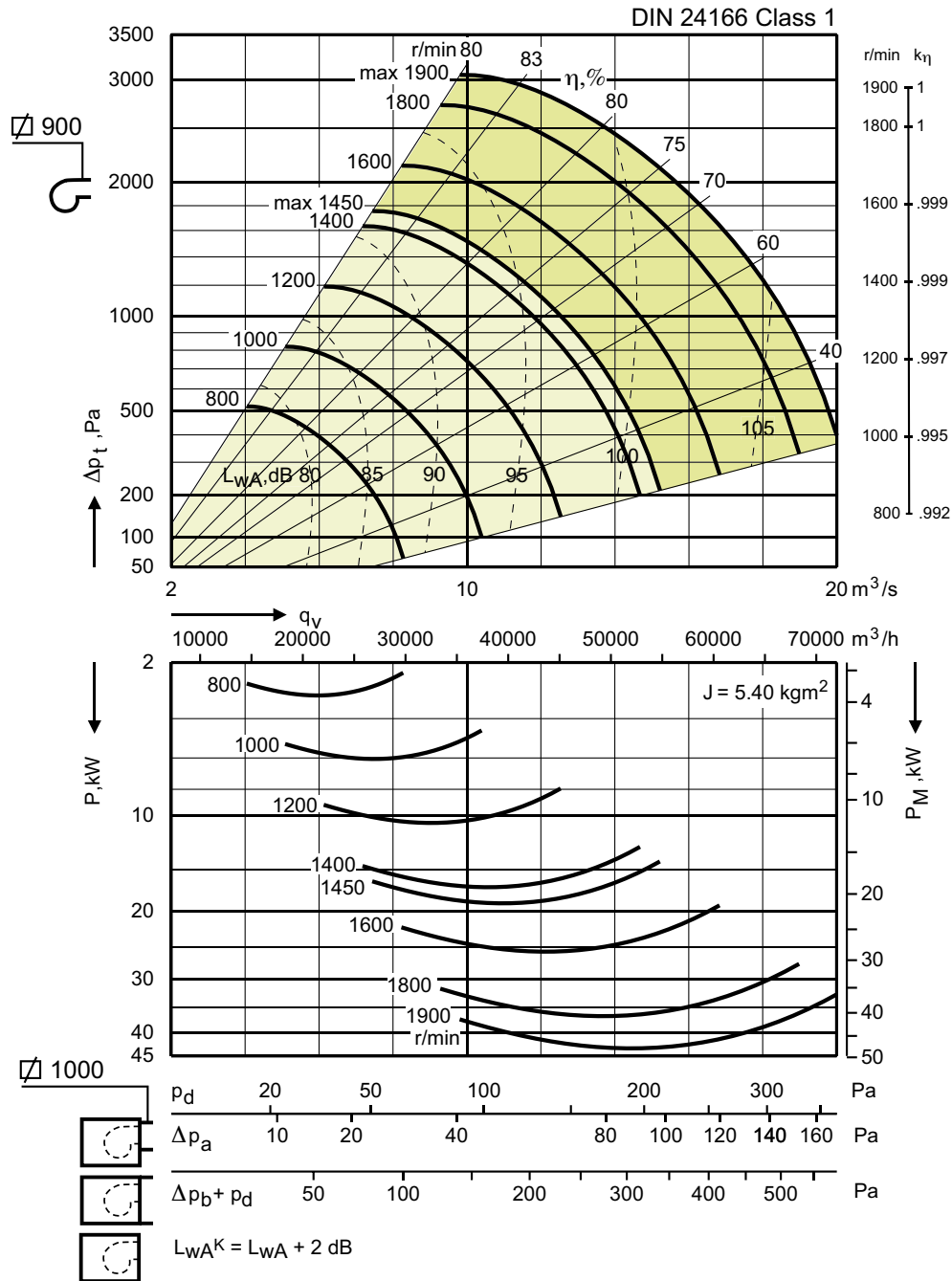

For embedded losses see the product selection tool ACON

Fan Charts

LQLR-60-3/62-2/64-1/71-1/80-1

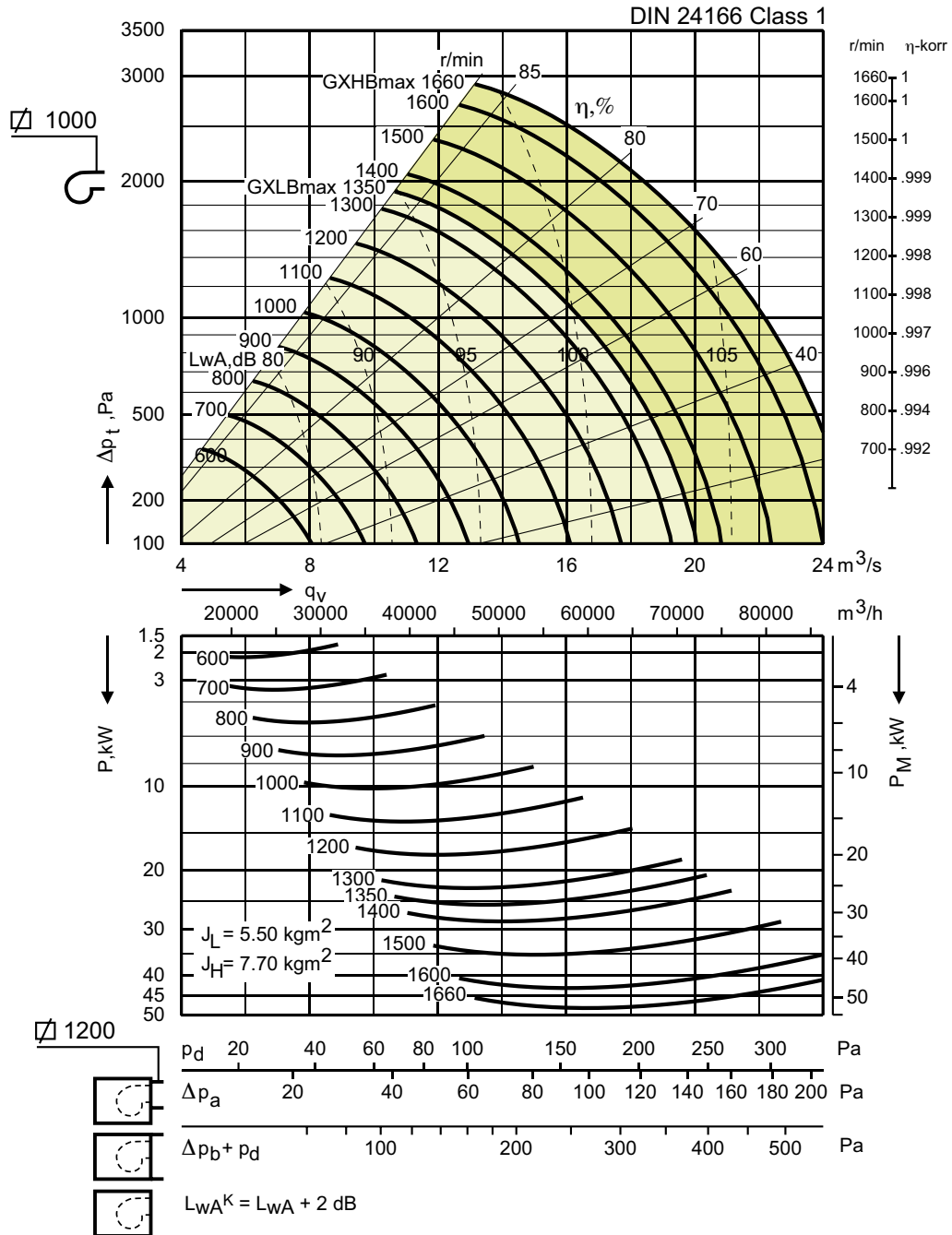

For embedded losses see the product selection tool ACON

Fan Charts

LQLR-62-3/64-2/71-2/73-1/80-2/82-1

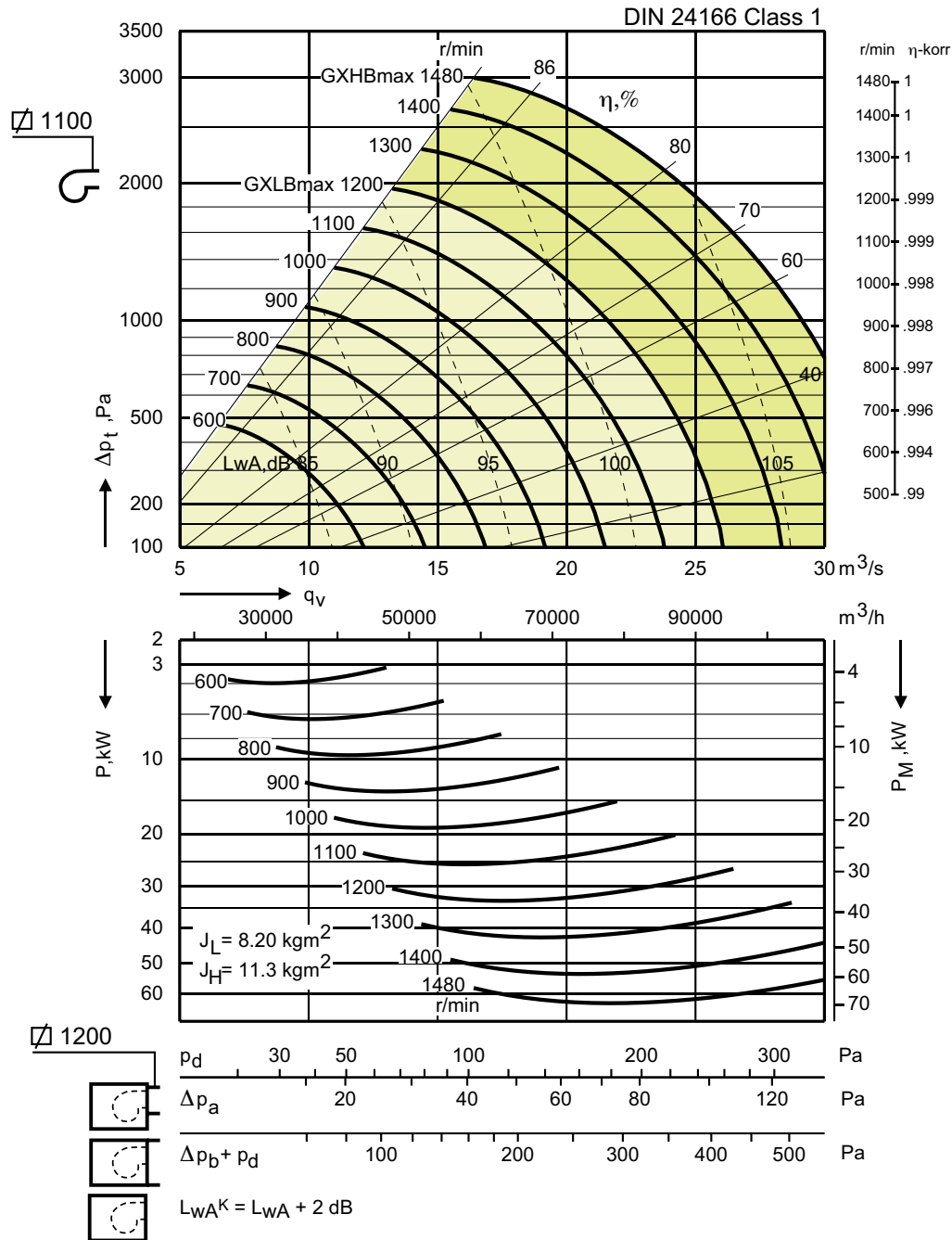

For embedded losses see the product selection tool ACON

Fan Charts

LQLR-64-3/71-3/73-2/80-3/82-2/84-1

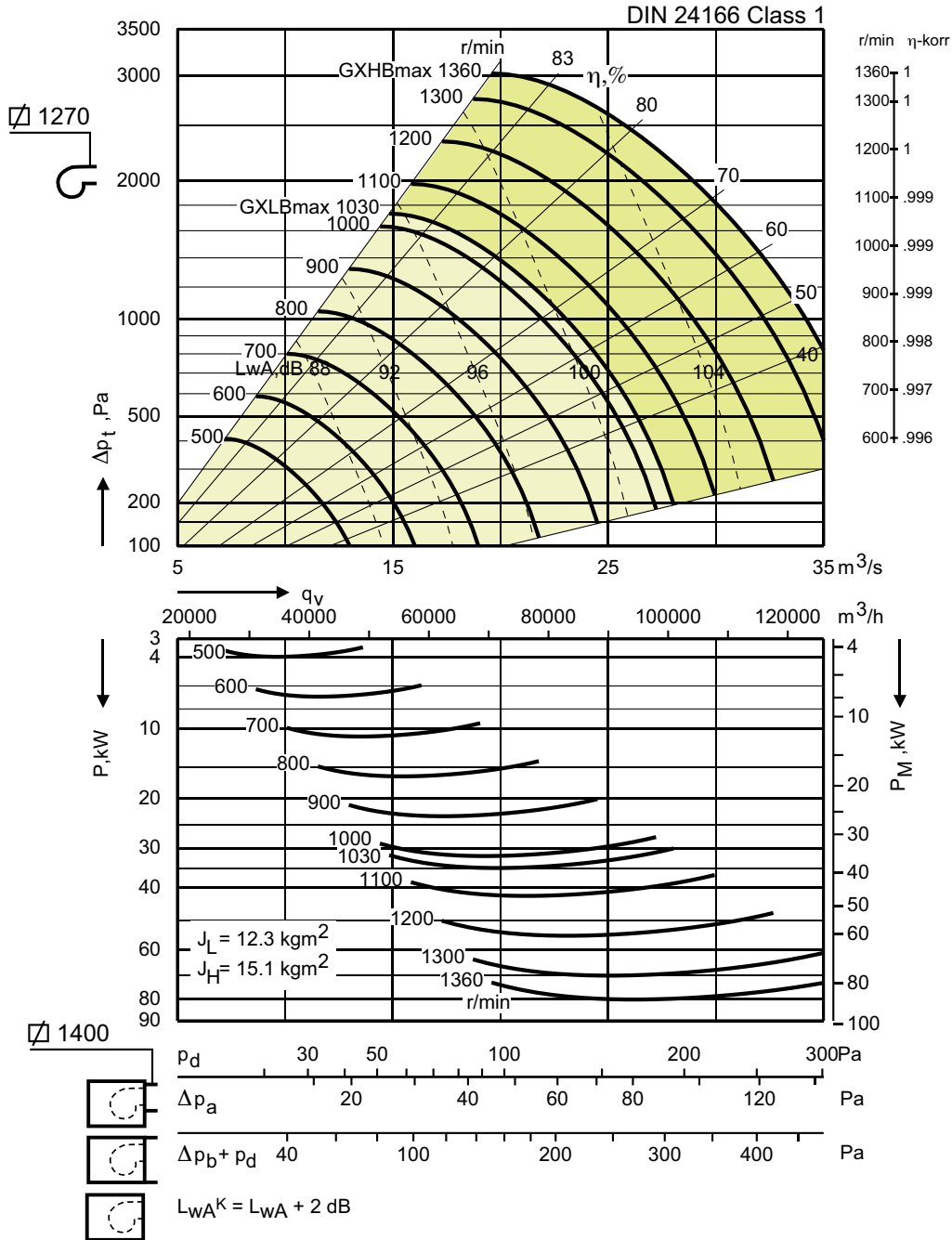

For embedded losses see the product selection tool ACON

Fan Charts

LQLR-73-3/82-3/84-2

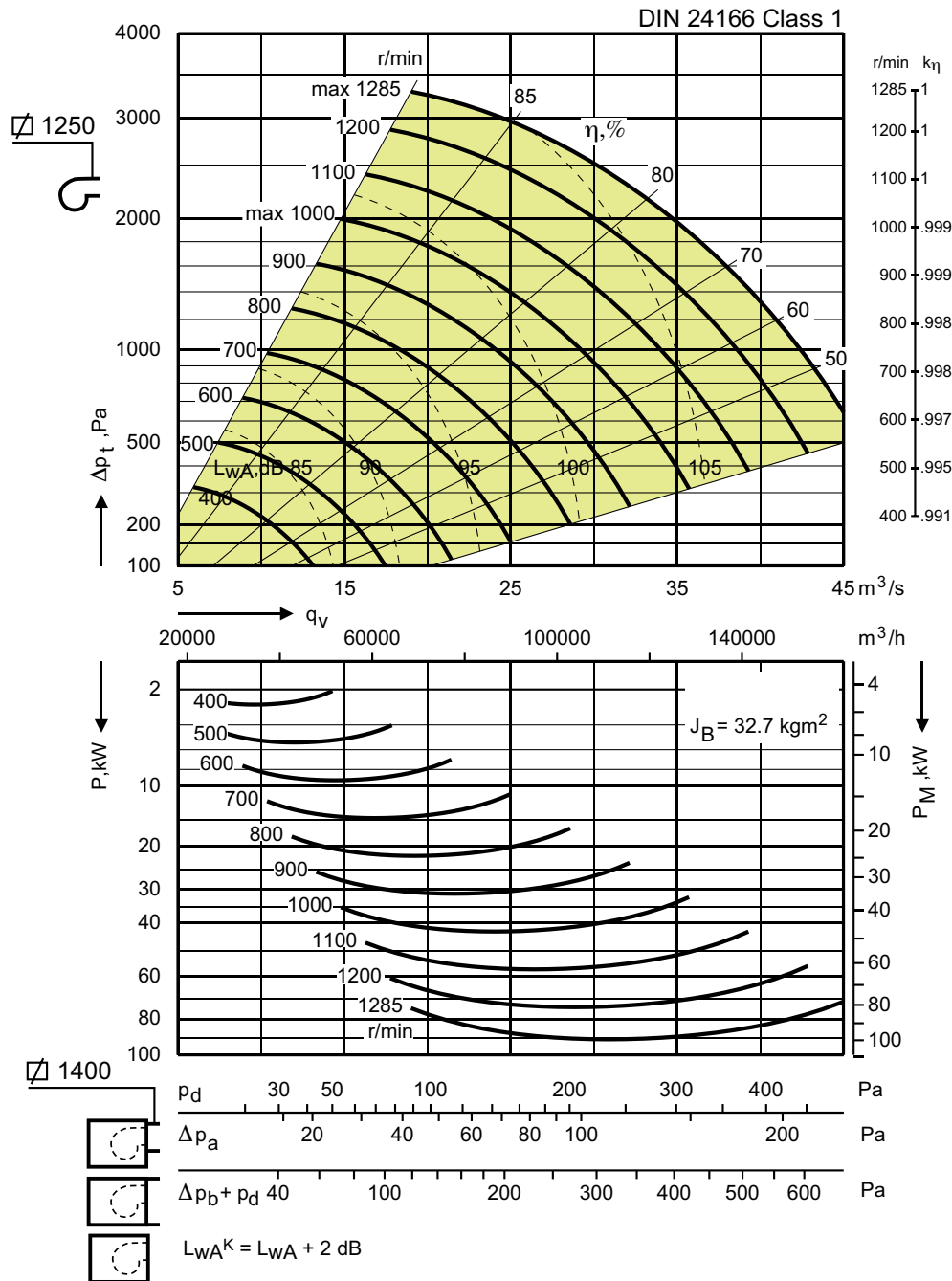

For embedded losses see the product selection tool ACON

Fan Charts

LQLR-84-3

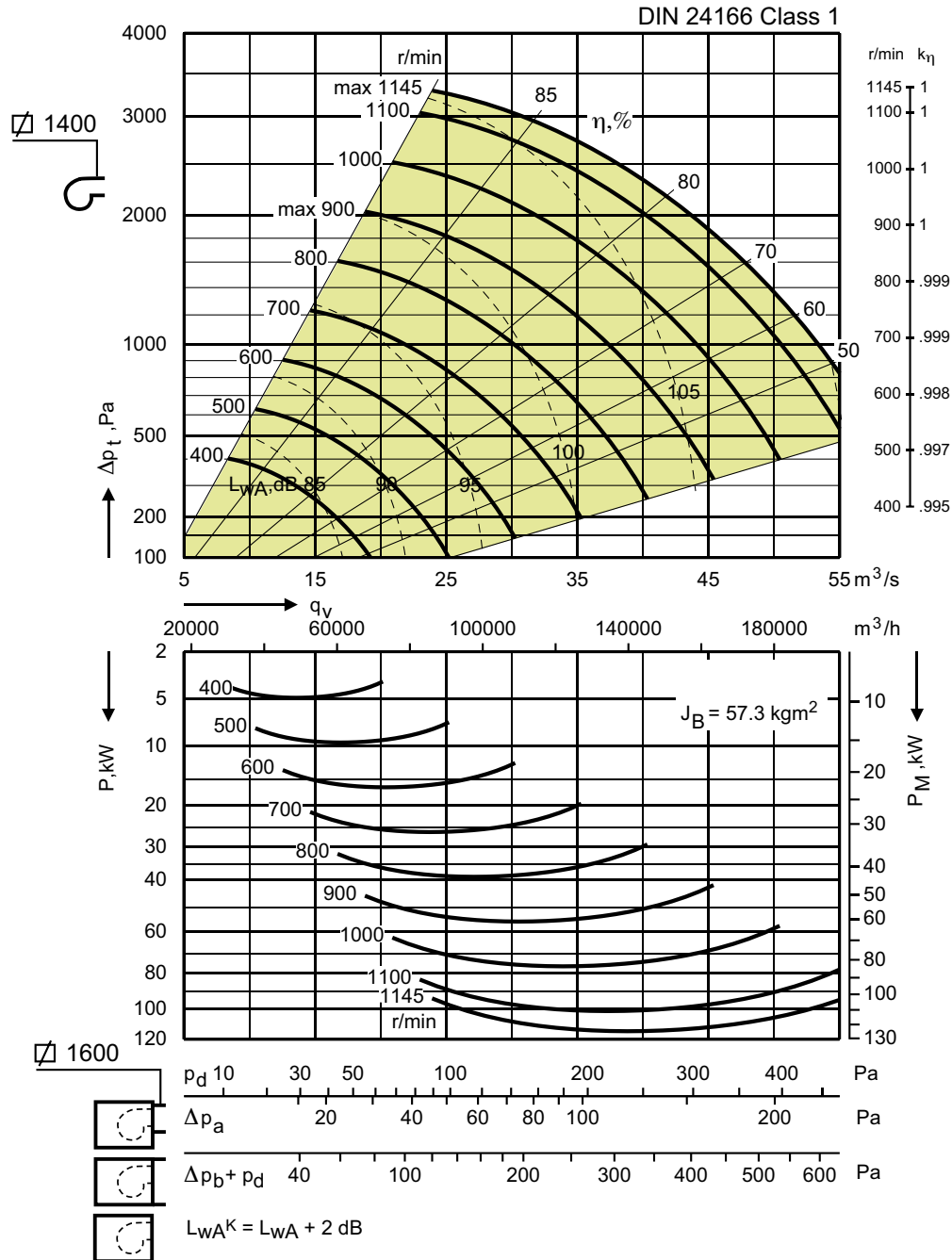

For embedded losses see the product selection tool ACON

Fan Charts

LQLK Plenum fan – Description

LQLK-55-1760-1/62-1

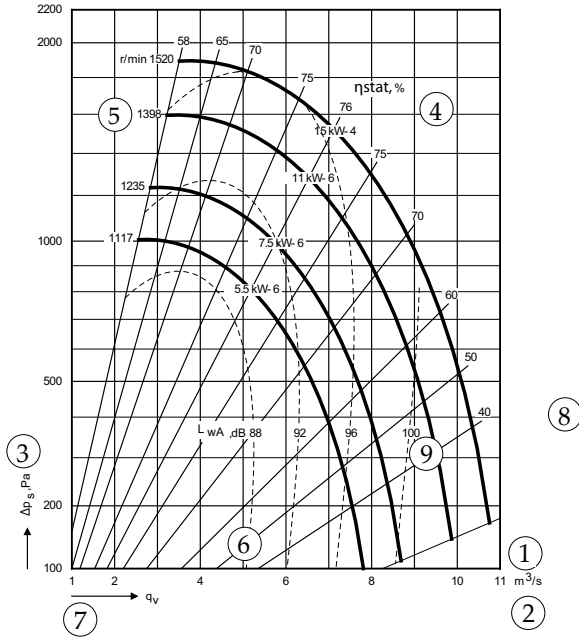

The fan charts on the pages that follow are applicable to a "naked" fan and to air with a density of $1,2 \text{ kg/m}^3$. An incorporation loss, Δp_1 , arises in the LQLK unit section when it has been incorporated into the air handling unit.

- ① = Air flow, m^3/s (x-axis)
- ② = Air flow, m^3/h (x-axis)
- ③ = Static pressure increase, Δp_s Pa (y-axis)
- ④ = Fan efficiency, η , %
- ⑤ = Max speed of each motor, kW – number of motor poles
- ⑥ = Total sound power level LwA (dB), broken line
- ⑦ = Incorporation loss Δp_1 Pa
- ⑧ = Unit size and fan size

Fan Charts

LQLK-55-1/60-1/62-1

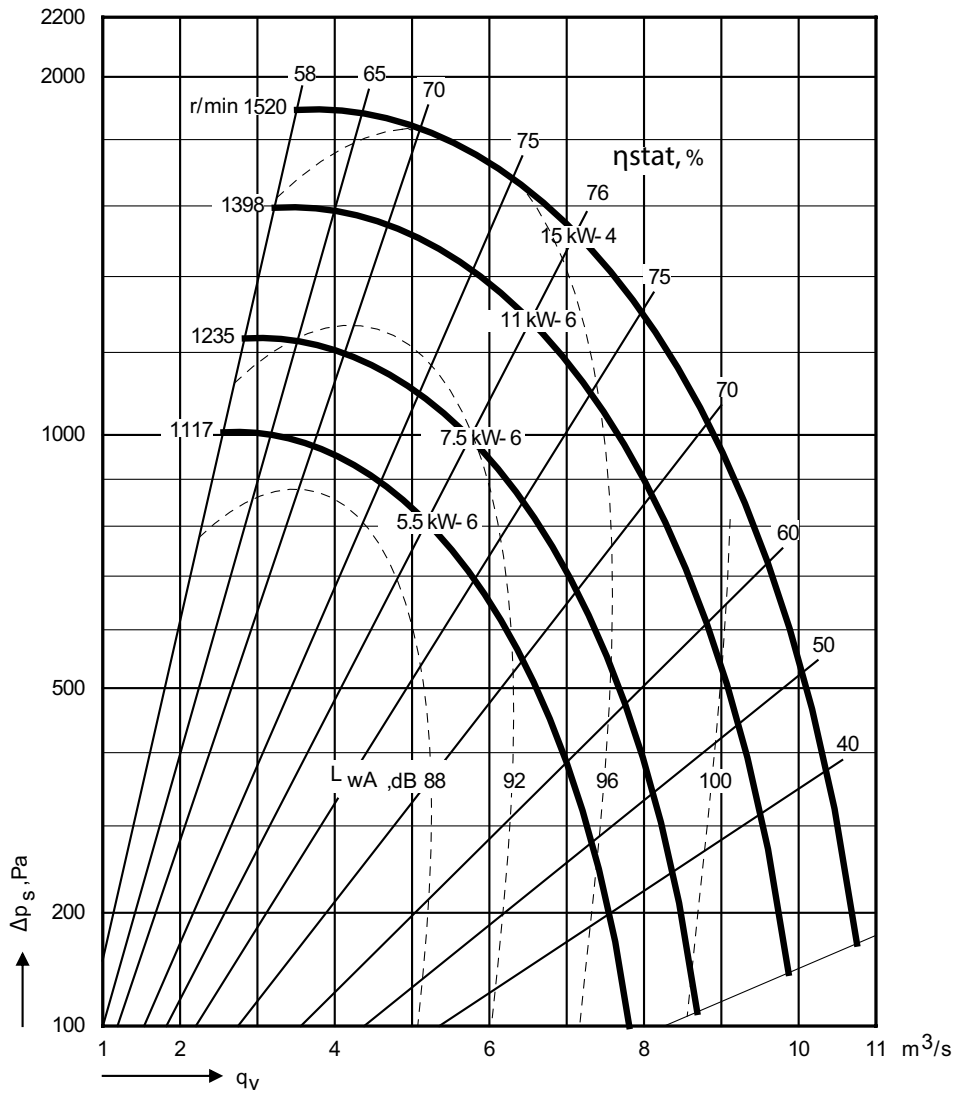

For embedded losses see the product selection tool ACON

Fan Charts

LQLK-55-2/60-2/62-2

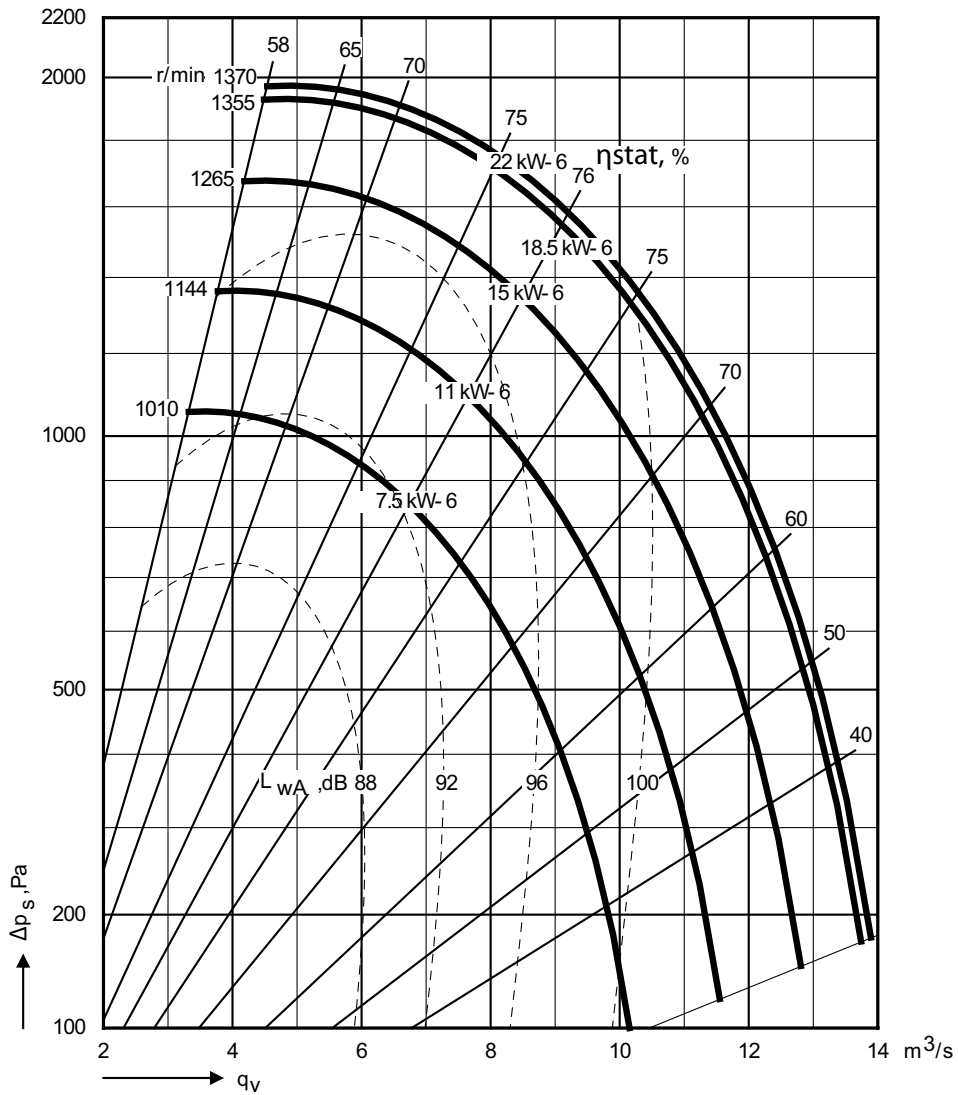

For embedded losses see the product selection tool ACON

Fan Charts

LQLK-55-8/62-3/64-2/66-2/71-2/73-2/75-1/80-2/82-1

Note! Two fans

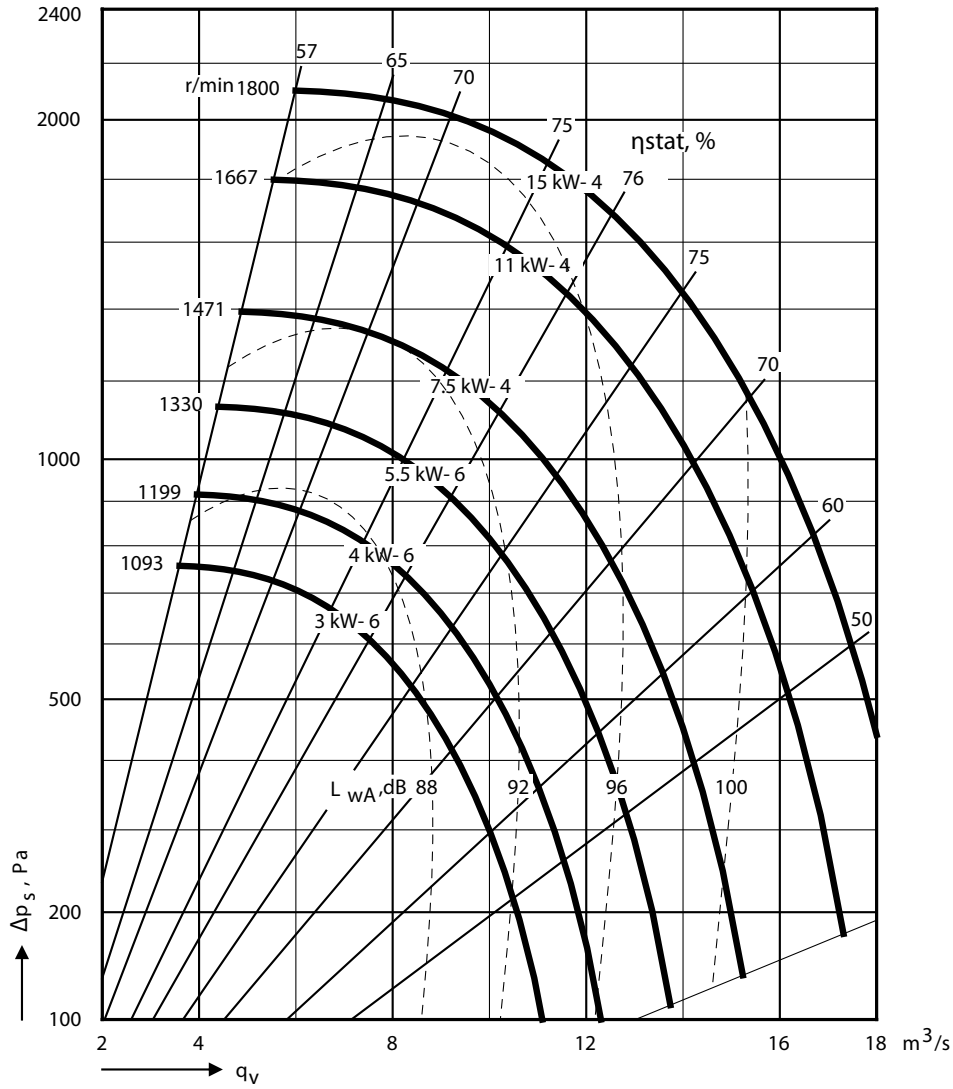

For embedded losses see the product selection tool ACON

Fan Charts

LQLK-60-3/64-1/66-1/71-1/73-1/80-1

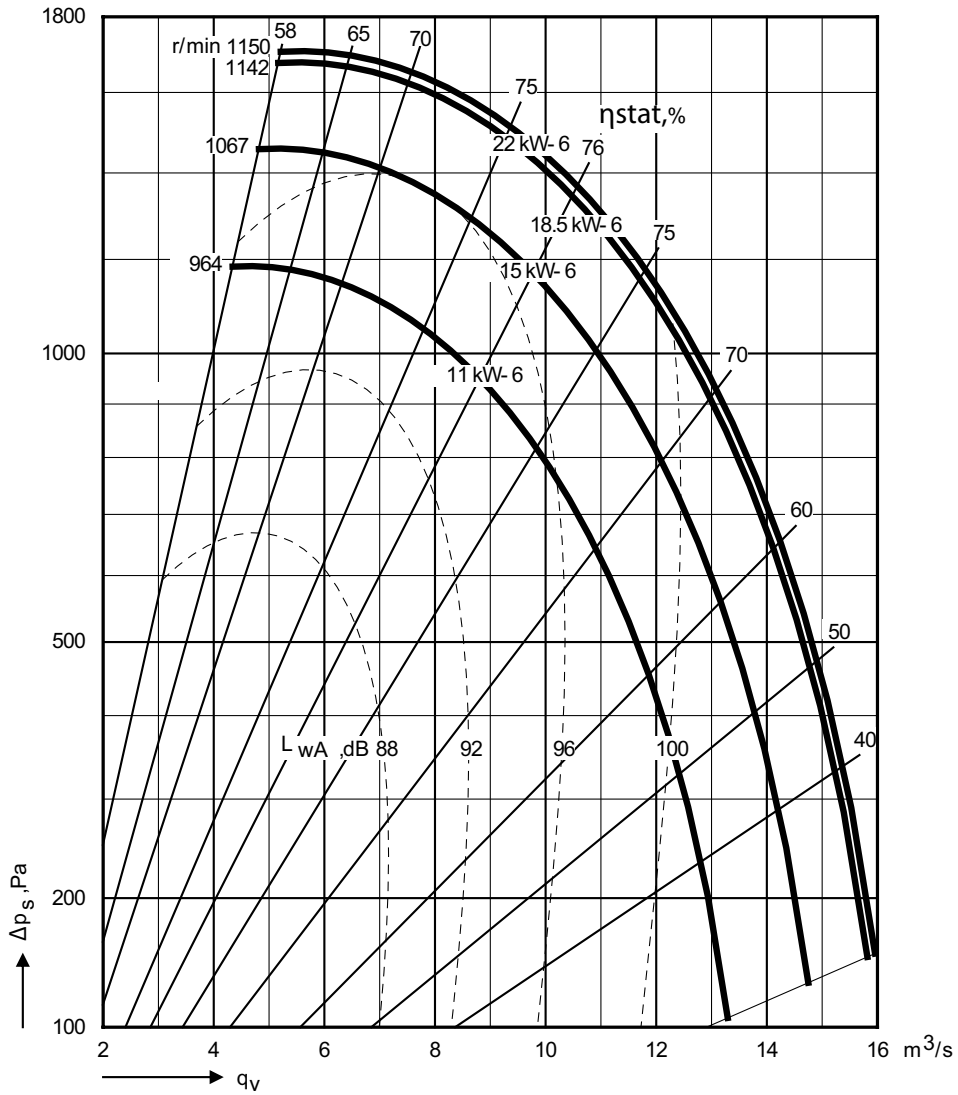

For embedded losses see the product selection tool ACON

Fan Charts

LQLK-64-3/66-3/73-3/75-2/82-2/84-1

Note! Two fans

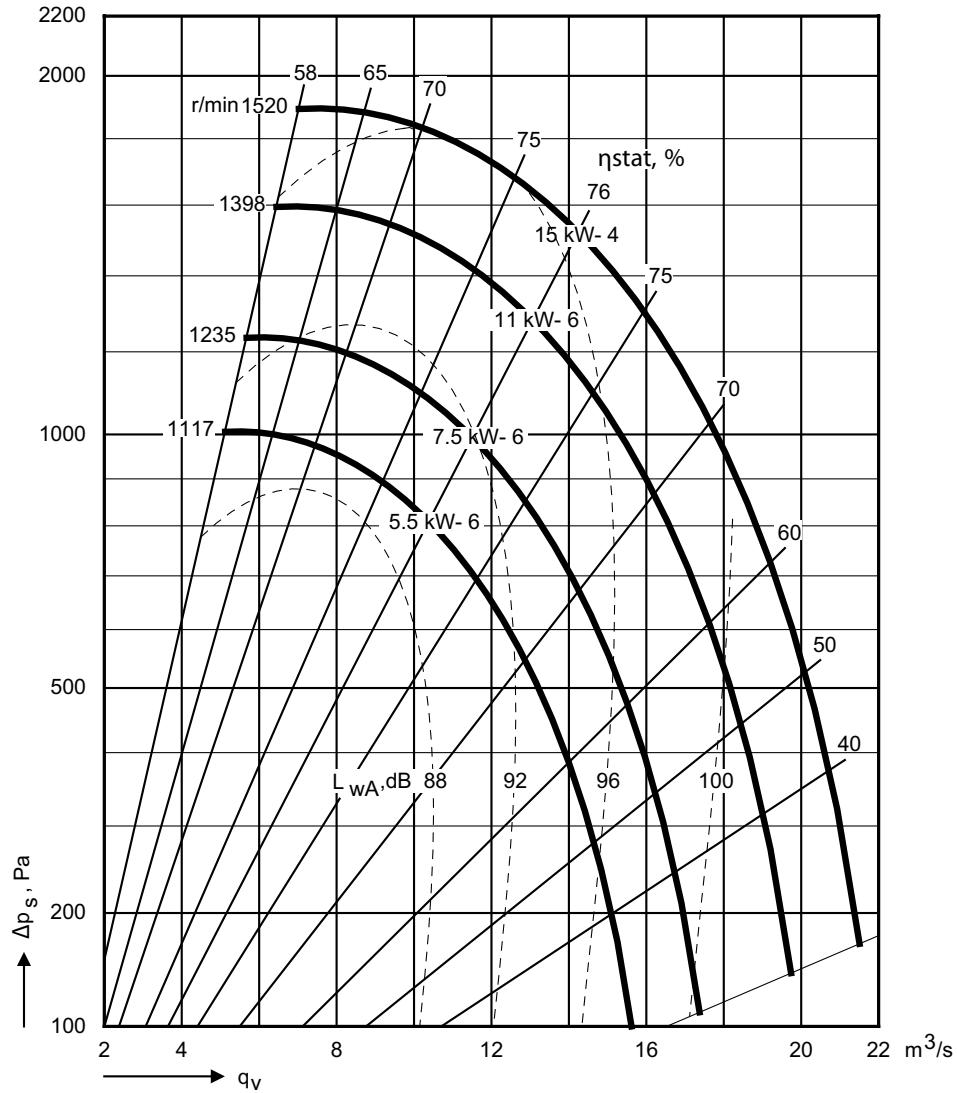

For embedded losses see the product selection tool ACON

Fan Charts

LQLK-64-4/66-4/73-4/75-3/82-3/84-2

Note! Two fans

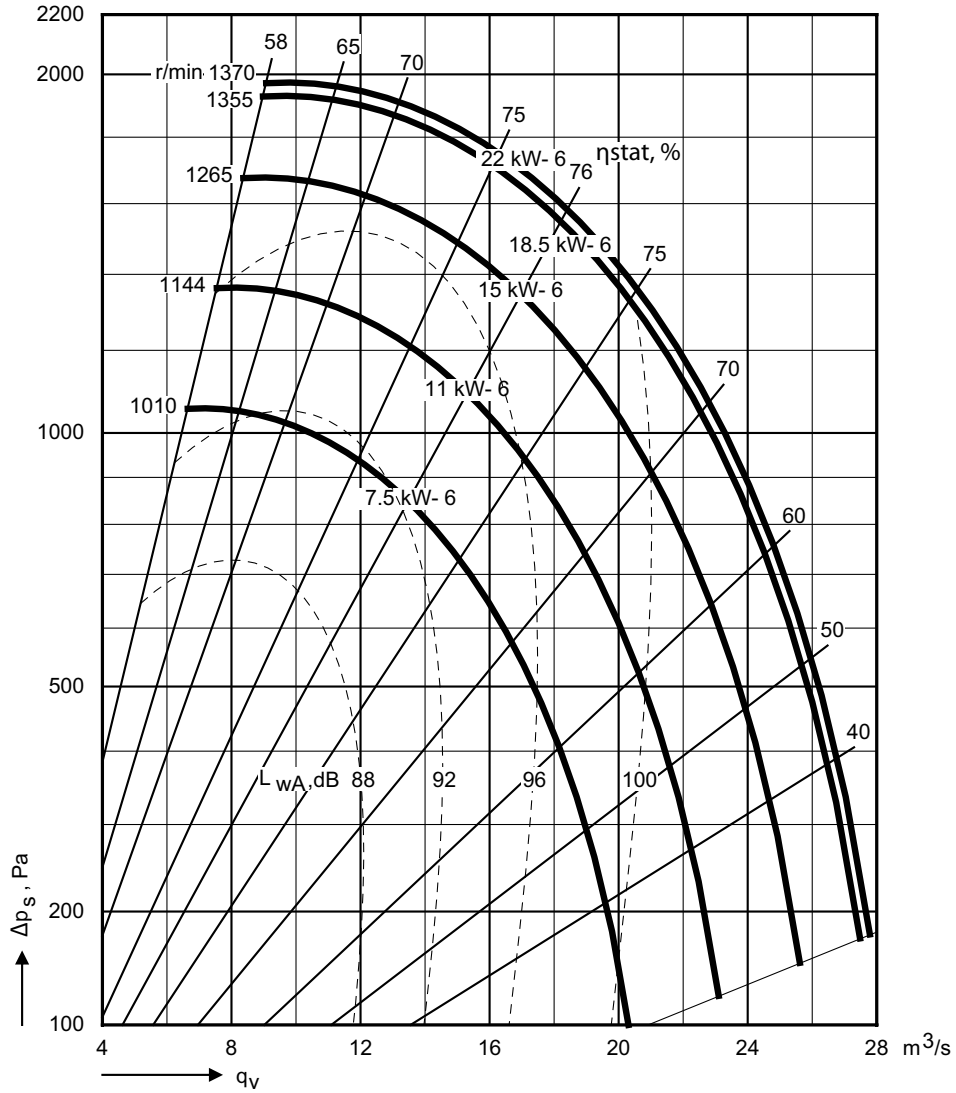

For embedded losses see the product selection tool ACON

Fan Charts

LQLK-75-4/84-3

Note! Two fans

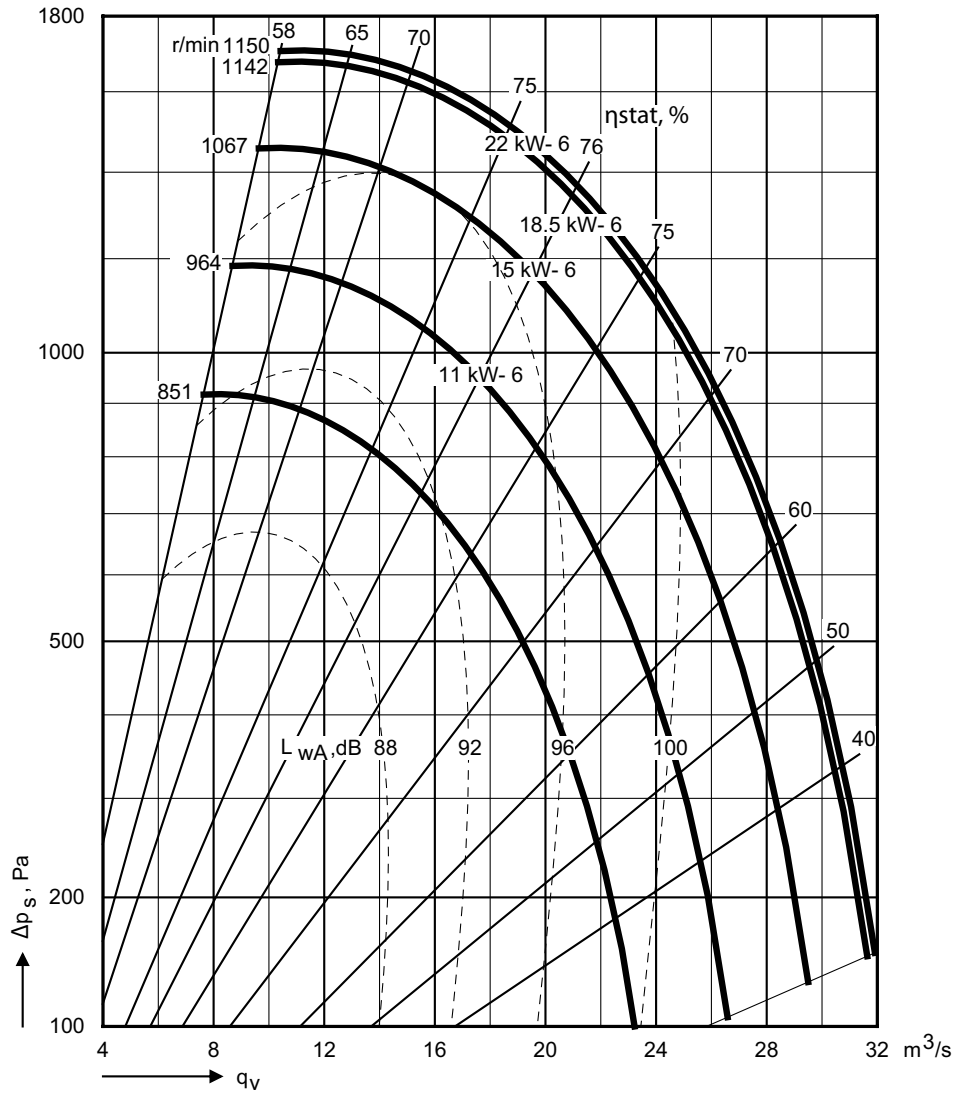

For embedded losses see the product selection tool ACON

Descriptive Texts

Introduction

The following descriptive texts are intended for use by consultants, engineers and planners to assist them in the specification of the eQL air handling units from Fläkt Woods.

The texts describe the units in the standard version along with various options such as different materials, capacity variants and extra functions, etc.

Accessories of various types are also described under each functional section.

Versions that differ from our standard units can be offered

after contact with our product sales organisation.

The specification should also include input data:

a diagrammatic drawing showing the arrangement of the unit's functional sections in relation to one another.

All these details including a detailed dimension print can be obtained from our product selection software for the eQL.

Since we are constantly involved in improving and renewing our air handling units, we reserve the right to make design changes without prior notice.



Descriptive Texts

Unit Design

The air handling unit shall consist of a framework to which panels are secured. The framework shall consist of closed, box-section members made of aluminium-zinc plated steel with a metal thickness of 1.5 mm (1.8 mm on the larger units, eQL 60 – 84).

The frame members shall be secured to corner pieces by means of two bolts at each leg.

The panels shall be of double-skin design with intervening incombustible mineral wool with a density of 50 or 140 kg / m³. All the panels shall be removable by removing the fixing screws from outside the framework. All the inspection doors shall have mechanically fastened sealing strips.

It shall be possible to sectionalize the air handling unit and later reassemble it at the building site.

The panels and frame members shall be designed with smooth interior and exterior surfaces without sharp edges and without pockets where dirt can collect.

The casing shall have a heat transfer coefficient that conforms to Class CEN T3 and tightness that conforms to CEN A or CEN B Standard.

The attenuation of the casing has been tested to EN 188b and ISO 3744-19.

Sheet metal mm	Insulation kg/m ³	Oktave band to ISO							
		63	125	250	500	1K	2K	4K	8K
0,7	50	10	10	19	29	31	28	32	33
0,7	140	12	12	22	29	28	26	27	29
1,0	50	12	12	22	29	28	26	27	29
1,0	140	13	15	23	29	31	29	31	33

The air handling unit shall be manufactured in a production facility that has a certified Quality Assurance. System defined by ISO 9001 (BS 5750 Section 1) and a certified Environmental .

Material in the panels:

0,7 mm thick galvanized sheet steel

1,0 mm thick galvanized sheet steel

1,0 mm thick galvanized sheet steel with polyester-coated surfaces (C4 for external surfaces, C4 for internal surfaces as well if components are selected in stainless version)

0,7 mm thick stainless sheet steel, AISI 304 or ISO 2333

0,7 mm thick stainless sheet steel, AISI 316 or ISO 2343.

Material in frame work:

1,8 mm thick aluminium-zinc plated steel profiled sections (eQL 60 – 84).

1,8 mm thick epoxy-painted, aluminium-zinc plated steel profiled sections (eQL 60 – 84).

Outdoor version

The air handling unit in the outdoor version shall be sealed on the outside of the casing with permanently elastic sealing compound and shall be equipped with a roof and a 150 mm high base frame. The outdoor air intake shall have an air intake grille with vertical labyrinth-shaped vanes that prevent snow and rain from entering the unit with the air. Outlet opening equipped with a cowl and a protective screen. In other respects, this version is the same as the indoor version.

Hygienic version

(This version is described as a normal indoor version plus extra features.)

The panels shall be made of galvanized sheet steel / stainless sheet steel. The internal joints at the bottom, rear side panel shall be sealed with jointing compound. Special jointing compound requirements?

Optional:

A drain trough shall be mounted along the inspection side as a simple means of collecting and carrying off washing liquid.

Descriptive Texts

Inspection

The inspection sections shall be available for selection where required to enable inspection and service. The coils, heat exchanger, filters and fans shall be withdrawable. The inspection, filter and fan sections shall have inspection doors with adjustable hinges. The doors shall be equipped with lock plates and robust handles.

The air handling units, which can be entered, shall have door handles inside and reinforced non-slip floors.

Optional:

The inspection sections shall be equipped with a light fitting and the inspection doors with a window. The inspection doors shall be removable, without hinges, with at least 4 handles.

Duct Connections

The inlet and outlet openings shall be equipped with connection frames for PG slip-clamp joints or with flange, or with flexible connection for PG slip-clamp or

flange jointing. The fitter shall make sure that the ducts are properly fitted so that the flexible connection will not be deformed in any way.

Dampers

The dampers shall conform to Tightness Class CEN T4 or T5 and have contra-rotating blades made of galvanized or stainless sheet steel.

The edges of the damper blades shall be fitted with seals. The damper shafts shall be supported in permanently lubricated bearings.

Mixing Section

The dampers shall conform to Tightness Class CEN T4 or T5 and have contra-rotating blades made of galvanized or stainless sheet steel. The edges of the damper blades shall be fitted with seals.

The damper shafts shall be supported in permanently lubricated bearings. The air intake sections shall be equipped with connection frames with flexible connection for PG slip clamp or flanged joints.

Descriptive Texts

Filter Sections

The filter cassettes shall be sealed against the mounting rails by means of an eccentric locking device and gaskets with permanent elasticity for tightness that conforms to the relevant filter class. Pressure measurement tappings shall be integrated into the frame member to enable the connection of a manometer or filter pressure monitors. The filter material shall be fire-resistant, incombustible, odourless and environmentally compatible.

Accessories:

Filter manometer, analogue or digital
Filter monitor
Differential pressure gauge built into the panel.

Panel filters

The filters shall be pleated to obtain a large, effective surface and shall be supported by a wire mesh mat and a sheet metal frame. Washable or disposable filter medium.

The filter cassettes shall be with drawables from the side via an inspection door. Class G2, G3 or G4 filters conforming to EN779 shall be selection options.

Bag filter, medium long

The filter shall be 360 mm deep, made of synthetic material or a compact filter. Class F3, F4 or F5 filters conforming to EN779 shall be selection options.

Optional:

The filter sections shall be equipped with a trough.

Bag filters, long

The filters shall be 550–630 mm deep made of synthetic material or of glass fibre.

Class G3, G4 or F5, F6, F7, F8, F9 filters conforming to EN779 shall be selection options.

Absolute filters

The filter sections shall consist of a fully-welded stainless filter wall mounted between two modules designed to make air leakage past the filters impossible. The filter section shall be a separate module with an inspection door upstream of the filter, to enable filter changes from the fouled side of the filter medium. An inspection section with door shall be situated downstream of the filter.

The filter shall be 300 mm deep and shall be of Camfil manufacture. Class H10, H12, H13, H14. H13 and H14 filters conforming to EN779 shall be selection options and H14 shall be scanned.

Carbon filters

The carbon filters for activated carbon shall be of cylinder type for connection to a mounting plate by means of a bayonet fitting.

Descriptive Texts

Air heaters, for hot water

The air heating coils shall be fabricated of copper tubes that have been expanded against aluminium fins. The headers are made of copper or corrosion-resistant steel. Assembly parts are made of galvanized / stainless sheet steel. The coil body shall be mounted on slide rails to be withdrawable.

The coil connections shall protrude out through the side panel of the air handling unit and shall be adequately sealed to prevent air leakage. The coil shall be equipped with connections for venting or drainage. All connections shall be labelled with out / in labels.

Electric air heaters

Electric air heaters for 3 x 230 V or 3 x 400 V. The heating elements shall be of high / low temperature type and shall be equipped with overheat protection. The air heater shall not contain asbestos.

The air heater output shall be broken down into a number or power steps so that each of them will not change the outlet temperature more than 1.5 degrees. The air heater shall have degree of protection IP43 to IEC 529.

Air coolers, for chilled water

The air cooling coils shall be fabricated of copper tubes that have been expanded against aluminium fins. The headers are made of copper or corrosion-resistant steel. Assembly parts are made of galvanized / stainless sheet steel. The coil shall stand on a sloping, stainless drip tray with drain connection on the inspection side of the air handling unit. The drip tray shall prevent condensate from remaining in the air handling unit and shall prevent condensate from spreading further in the air handling unit. The fitter shall see to it that the condensate discharge pipework is connected across a water trap and run to a floor gully.

Air coolers having a height of more than 1200 mm shall be equipped with a sloping intermediate tray made of stainless steel.

The coils connections shall protrude out through the side panel of the air handling unit and shall be effectively sealed against the inner and outer casing skins to prevent leakage. The coil shall be equipped with connections for venting or drainage. All connections shall be labelled with out / in labels.

Optional:

Droplet eliminator made of plastic, fixed or with drawable. The drip tray shall be with drawable.

Accessory:

Water trap

Descriptive Texts

Air coolers, direct expansion (dx)

The air cooling coils shall be fabricated of copper tubes that have been expanded against aluminium fins. The headers and distributor tubes are made of copper or corrosion-resistant steel. Assembly parts are made of galvanized / stainless sheet steel. The coil body shall be mounted on slide rails to be with drawable. The coil shall stand on a sloping, stainless drip tray with drain connection on the outside of the air handling unit.

The drip tray shall prevent condensate from remaining in the air handling unit and prevent condensate from spreading further in the air handling unit. The fitter shall see to it that the condensate discharge pipework is connected across a water trap and run to a floor gully. The coils shall be hydrostatically tested, dried and filled with nitrogen. The connections shall be sealed off by brazing. All connections shall be labelled with out / in labels.

Air cooler (incl. compressors, evaporators and condensers)

The cooling unit shall be a complete functional section ready to be connected to the air handling unit. Supply air / extract air shall be in the bottom / top deck. The supply air shall be cooled by an air cooler, which transfers heat to the condenser in the extract air. The cooling unit shall be controlled by a 0 – 10 V external control signal. The cooling unit shall be equipped with an operating thermostat, which in the event of a temporary extreme cooling load, stops one compressor

to prevent a shut down yet enables the unit to generate 2/3 of its cooling capacity. The operating thermostat shall reset itself automatically.

Optional:

Water-cooled condenser. Shall be used when the extract air flow is too low for the air-cooled condenser only and / or in the event of extremely high outdoor air temperature conditions.

Humidifier, evaporative

The air humidifier shall consist of an unheated fill, PLUSFILL® of corrugated, hygroscopic aluminium fins. A corrosion-resistant distribution system complete with pump shall be included. The water tray is made of stainless sheet steel and shall slop towards the drain connection to facilitate cleaning and to prevent water from remaining in the tray during periods when the humidifier is not being used. The water bleed-off system shall minimise both water consumption and the concentration of salts. The humidifier shall be equipped with a control unit that automatically empties the drip tray if the unit is not used during a longer period and enables adjustment

of the intervals between emptying. The humidifier shall be equipped with an extra outlet to enable the tray to be emptied regularly. The humidifier shall have a droplet eliminator that prevents droplet entrainment by the air to other sections in the air handling unit.

Optional:

The humidifier shall be supplied for once-through water.

Accessory:

Water trap

Humidifier, steam

The humidification part shall contain a stainless drip tray and shall have provision for subsequent installation of a humidifier steam lance at the building site.

Descriptive Texts

Rotary heat exchanger, REGOTERM

The rotary heat exchanger shall be installed in the same type of casing as the other air handling unit sections. This functional section may, however, be wider than the other sections of the air handling unit. The rotor shall be made of thin aluminium foil. The heat exchanger shall be mounted in a stable casing with an inspection door equipped with a door lock. The rotor shall have a water-resistant, adjustable seal that prevents peripheral air leakage. The bearings shall be of permanently lubricated type. The rotor shall be driven by a variable/constant speed drive motor. A speed detection unit shall be included for regulating the speed of the rotor.

The rotary heat exchanger shall be designed for sensible heat transfer only and be of non-hygroscopic type

or

The rotary heat exchanger shall be designed for both sensible and latent heat transfer and be of hygroscopic type.

Optional:

The edges of the rotor foil shall be corrosion resistant, i.e. have so-called edge reinforcement.

Plate heat exchanger, RECUTERM

Heat exchanger of cross-flow type made of thin aluminium plates. It shall be equipped with a by-pass damper. The heat exchanger shall have a stainless drip tray on both the supply air and extract air side. If the extract air flows downward through the cube, a droplet eliminator

must be fitted downstream of the cube. The casing shall have inspection covers.

The heat exchanger shall have sectionalised defrosting or defrosting according to the "cold corner" principle.

Liquid-coupled heat exchangers, ECOTERM

The heat exchangers shall consist of finned-tube coils arranged in the supply and extract air handling units respectively. The coil on the supply air side corresponds to the description of the heating coils for hot water and

the coil on the extract air side corresponds to the description of the cooling coils for chilled water.

The plumbing work, pumps and control unit are neither supplied nor installed by Fläkt Woods.

Liquid-coupled heat exchangers, external energy, ECONET

The heat exchangers shall consist of finned-tube coils arranged in the supply and extract air handling units respectively. The coils correspond to the description of the cooling coils for chilled water.

The liquid circuit shall have connections for externally supplied energy: heating/cooling energy. A pump unit including pipe fittings and a frequency inverter for controlling the speed of the pump motor shall be supplied for the liquid circuit.

A control unit shall be included in the supply for the liquid circuit control function. The controller in the control unit cubicle shall be equipped with software that optimises the circulation flow in the circuit for

every operating condition as well as performance monitoring and frost protection. The pressure and temperature sensors required for the control function shall be included.

The liquid circuit shall include tapping's for measuring the circulation flow rate. Gauges for measuring the temperature and pump pressure shall be included.

Adjustments/commissioning at the installation site shall be included.

Plumbing work and electrical installation between the components of the heat exchanger are not included in Fan Wood's supply.

Descriptive Texts

Belt-driven centrifugal fans

The fans shall be of belt-driven design with spiral casing and have fan impellers with forward-curved/backward-curved blades.

The base beams of the fan unit shall be effectively isolated from the air handling unit casing by means of anti-vibration mountings and a flexible connection.

Recommendation:

Fans with forward-curved blades, for smaller air handling units and if optimal fan-power efficiency is not vitally important.

Fans with backward-curved blades, if optimal fan-power efficiency is paramount.

The air intake of the fans shall be via the cross section/rear/roof/bottom of the unit casing.

The fan outlet shall be arranged forward/upward/downward.

The fan material shall be galvanized sheet steel / stainless sheet steel (fan casing, impeller, belt guard have an epoxy painted finish)

Optional:

- frequency inverter
- adjustable guide vanes
- air flow measurement
- spark-proof version
- with single-speed motor / two-speed motor (1:2, 1:1, 5) two single-speed motors
- bimetallic / thermistor type temperature monitor in motor
- belt drive with V belt / flat belt
- belt drive guard / protective screen behind door
- light fitting
- motor and belt drive, internal / external
- Anti-vibration mountings, rubber mountings / steel springs.

Direct-driven axial-flow fans

Direct-driven axial-flow fans with the impeller mounted directly on the motor shaft. The impeller shall have blades that are adjustable while the fan is operating to meet the pressure needs of the system.

The fan shall have stable pressure / flow characteristics to eliminate risk of surging.

Are selected for plants in which low vibration levels and large air flows are required.

The fan inlet and outlet via the air handling unit cross section.

The fan material shall be galvanized sheet steel / stainless sheet steel (epoxy-painted fan).

Alternatives:

- number of blades / hub diameter / blade angle for optimizing the fan for every need
- 4-pole / 6-pole foot motor
- pneumatic / electro-mechanical control.

Descriptive Texts

Direct-driven plenum fans

The fans shall be direct-driven, single-inlet centrifugal fans without spiral casing, so-called plenum fans. The impeller shall have backward-curved blades and shall be mounted directly on the shaft of a single-speed motor. The fan shall be isolated from the air handling unit casing by means of anti-vibration mountings and a flexible connection.

Recommendation:

The lack of spiral casing makes the fan impeller easily accessible for cleaning. The plenum fan is therefore specially well-suited for use in hygienic applications and in applications in which low vibration levels are required.

The fan shall always be combined with frequency in-

verter so that the fan speed can be adjusted to meet the pressure needs of the system.

The fan inlet via air handling unit cross section.

The fan outlet shall be arranged forward / upward / towards the rear of the unit.

The fan material shall be galvanized sheet steel / stainless sheet steel (epoxy-painted fan stand and fan impellers).

Optional:

- bimetallic / thermistor type temperature monitor in motor
- radial diffuser (for improving the efficiency)
- air flow measurement
- anti-vibration mountings, rubber mountings / steel springs.

Silencers

The silencers shall be fabricated in the same type of casing as the other air handling unit sections and contain vertical sound baffle elements. The sound-absorbing material shall be covered by woven fabric, dry / wet cleanable, which prevents fibres from migrating from the baffle elements. The insulating material shall be incombustible.

Optional:

The baffles shall be withdrawable.

Base frame

The base frame shall be made of robust galvanized sheet steel, 150 / 300 mm high, and be secured to the air handling unit at the factory

or

The base frame shall be delivered separately broken down into small parts to be assembled at the building site.

Optional:

The base frame shall be equipped with adjustable feet.

Accessories

The coils shall be equipped with flanges / counter-flanges
Spare filters are supplied with the unit
Spare belts for the belt drive are supplied with the unit.

Manufacture:

The air handling unit shall be of type eQL manufactured and designed by Fläkt Woods AB, Jönköping, Sweden.

Dimensions and weights

Unit casing

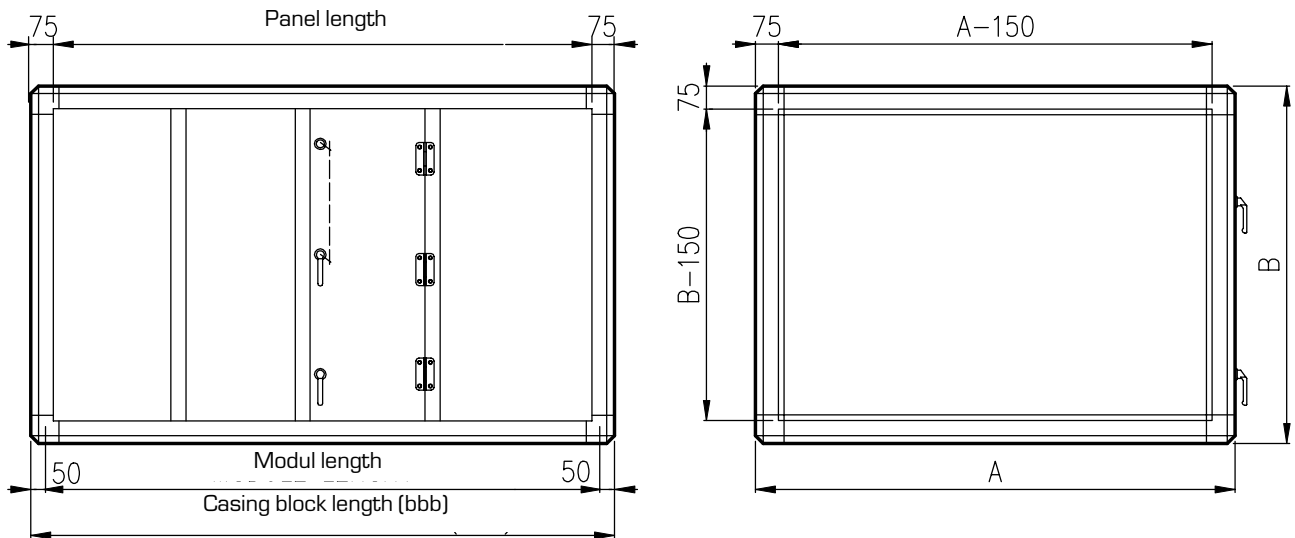

Size	A	B	Q ₁ Weight, kg/m	Q ₂ Weight, kg	Q ₃ Weight, kg	(Q ₄) Weight, kg	(Q ₅) Weight, kg
60	2050	2050	197	91	51	22	73
62	2650	2050	225	103	57	30	103
64	3250	2050	248	115	64	37	119
71	2650	2350	239	109	61	33	132
73	3250	2350	262	121	68	42	164
80	2650	2650	253	115	65	38	158
82	3250	2650	276	126	72	47	186
84	4000	2650	309	309	81	59	231

Possible casing lengths L (bbb), mm					
Size 60 – 84			Size 60,62,71,80		
350	1350	2200	3050	4050	5050
450	1400	2250	3100	4100	5100
550	1450	2300	3150	4150	5150
650	1500	2350	3200	4200	5200
700	1550	2400	3250	4250	5250
750	1600	2450	3300	4300	5300
800	1650	2500	3350	4350	5350
850	1700	2550	3400	4400	5400
900	1750	2600	3450	4450	5450
950	1800	2650	3500	4500	5500
1000	1850	2700	3550	4550	5550
1050	1900	2750	3600	4600	5600
1100	1950	2800	3650	4650	5650
1150	2000	2850	3700	4700	5700
1200	2050	2900	3750	4750	5750
1250	2100	2950	3800	4800	5800
1300	2150	3000	3850	4850	5850
			3900	4900	5900
			3950	4950	5950
			4000	5000	6000

Dimensions and weights

Stacked units

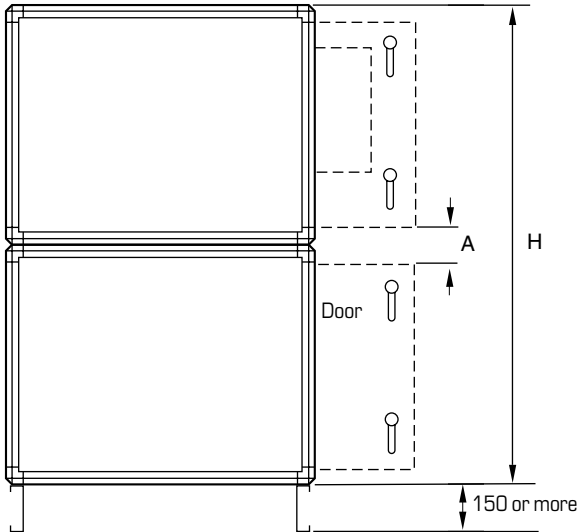

Note: Suitable provision must be made to provide safe working conditions during servicing. Remember that the upper unit will be well above the normal reach of most people!

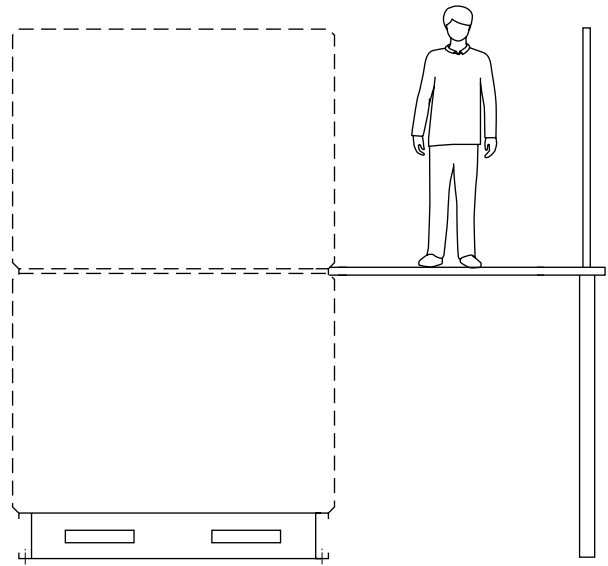

Size	H	A
60-64	4100	
71-73	4700	150
80-84	5300	

Inspection door

Standard

Pressure over

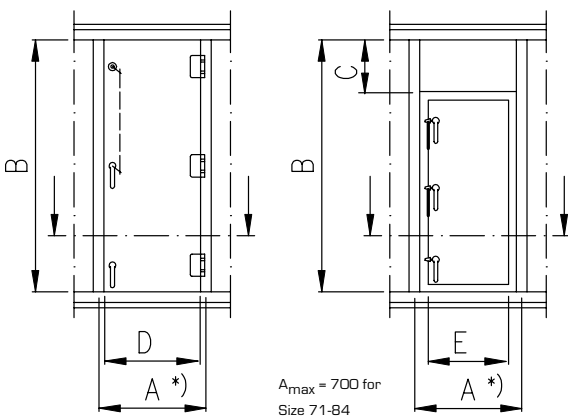

A_{max} = 700 for Size 71-84

Standard inspection door

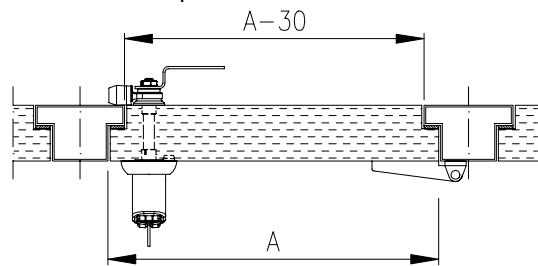

Inward opening inspection door for LQTC

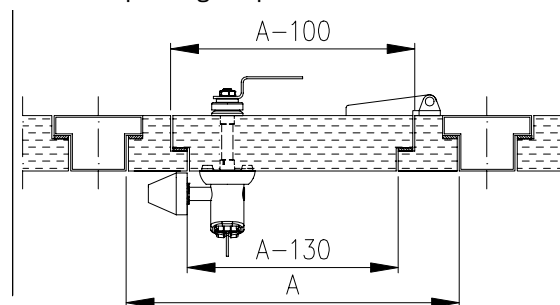

Size	B	C	Length A	250	350	450	550	650	750	900	1000
60-64	1900	-	Door D	200	300	400	500	600	700	600	600
71-73	2200	300	Door E	-	-	-	400	500	600	500	500
82-84	2500	600	Dimensions D, E designed for LQTC								

Dimensions and weights

Joining frame between modules of different size LQVH

Fitted to the larger block

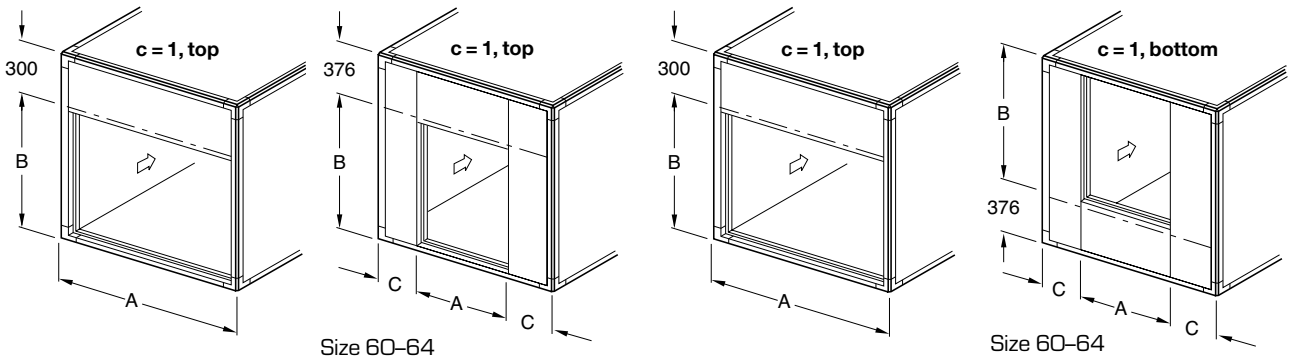

Size aa - bb	A	B	C	Weight, kg	
				Q ₁	Q ₂
71 - 62	2650	2050	-	24	4
73 - 64	3250	2050	-	30	5
80 - 71	2650	2350	-	24	4
82 - 73	3250	2350	-	30	5

Q₁ Weight, kg for 1 mm steel sheet and standard insulation. For panels with 0.7 mm sheet = x0, 7.

Q₂ Additional weight for casing with insulation (140 kg/m³).

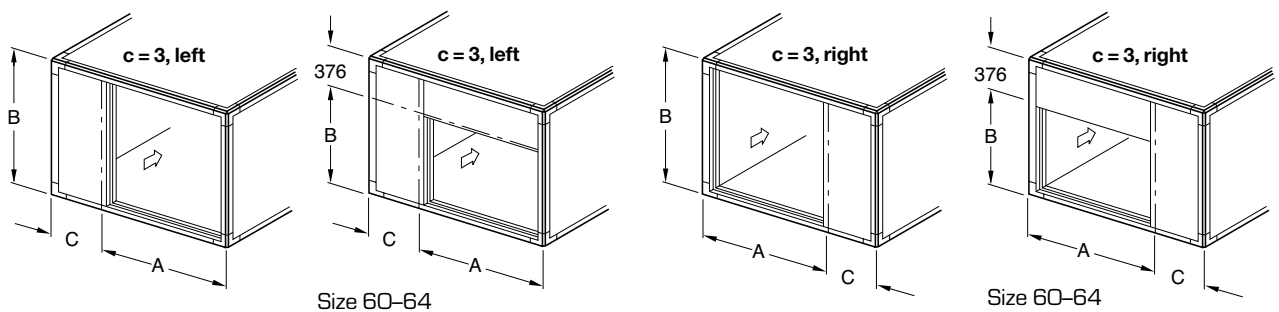

Size aa - bb	A	B	C	Weight, kg	
				Q ₁	Q ₂
62 - 60	2050	2050	600	30	6
64 - 62	2650	2050	600	30	6
82 - 80	2650	2650	600	39	9

Dimensions and weights

Base frame LQAZ-04

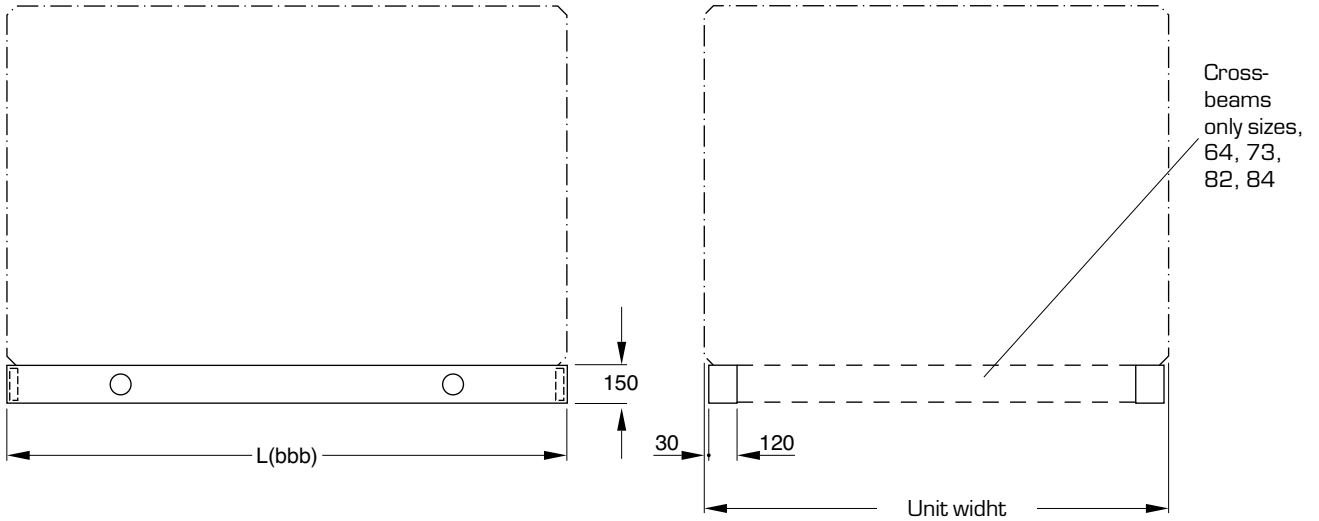

Length, L	350	450	550	650	700	750	800	850	900	950	1000	1050	1100
Code suffix (ccc)	035	045	055	065	070	075	080	085	090	095	100	105	110
Weight, kg	8	10	12	14	16	17	18	19	20	21	22	23	24
Length, L	1150	1200	1250	1300	1350	1400	1450	1500	1550	1600	1650	1700	1750
Code suffix (ccc)	115	120	125	130	135	140	145	150	155	160	165	170	175
Weight, kg	26	27	28	29	30	31	32	33	34	35	36	37	38
Length, L	1800	1850	1900	1950	2000	2050	2100	2150	2200	2250	2300	2350	2400
Code suffix (ccc)	180	185	190	195	200	205	210	215	220	225	230	235	240
Weight, kg	40	41	42	43	44	45	46	54	55	56	57	58	59
Length, L	2450	2500	2550	2600	2650	2700	2750	2800	2850	2900	2950	3000	3050
Code suffix (ccc)	245	250	255	260	265	270	275	280	285	290	295	300	305
Weight, kg	61	62	63	64	65	66	67	68	69	71	72	73	74
Length, L	3100	3150	3200	3250	3300	3350	3400	3450	3500	3550	3600	3650	3700
Code suffix (ccc)	310	315	320	325	330	335	340	345	350	355	360	365	370
Weight, kg	75	76	77	79	80	81	82	83	84	85	86	88	89
Length, L	3750	3800	3850	3900	3950	4000	4050	4100	4150	4200	4250	4300	4350
Code suffix (ccc)	375	380	385	390	395	400	405	410	415	420	425	430	435
Weight, kg	90	91	92	93	94	95	96	97	98	99	108	109	110
Length, L	4400	4450	4500	4550	4600	4650	4700	4750	4800	4850	4900	4950	5000
Code suffix (ccc)	440	445	450	455	460	465	470	475	480	485	490	495	500
Weight, kg	111	112	113	114	115	116	118	119	120	121	122	123	124
Length, L	5050	5100	5150	5200	5250	5300	5350	5400	5450	5500	5550	5600	5650
Code suffix (ccc)	505	510	515	520	525	530	535	540	545	550	555	560	565
Weight, kg	125	126	128	129	130	131	132	133	134	135	136	137	138
Length, L	5700	5750	5800	5850	5900	5950	6000						
Code suffix (ccc)	570	575	580	585	590	595	600						
Weight, kg	140	141	142	143	144	145	146						

Additional weight for cross beams				
Size	60	62,71,80	64,73,82	84
Weight, kg	-	-	30	38
Max.Length	600		300	
Code suffix (ccc)				

Dimensions and weights

Roof LQBZ-01

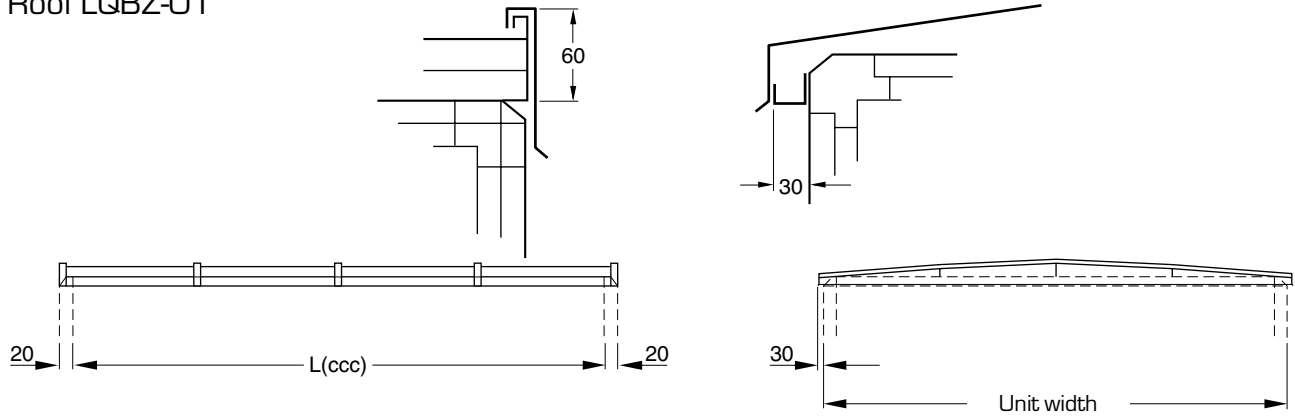

Length, L Code suffix (ccc)	Weight, kg 1)				Length, L Code suffix (ccc)	Weight, kg 1)				Length, L Code suffix (ccc)	Weight, kg 1)			
	60	62 71 80	64 73 82	84		60	62 71 80	64 73 82	84		60	62 71 80	64 73 82	84
035	25	30	36	44	235	79	93	110	134	420	135	161	187	220
045	27	33	40	48	240	81	95	112	136	425	136	162	189	222
055	30	36	43	52	245	82	96	113	138	430	138	164	191	225
065	32	39	46	56	250	83	98	115	140	435	139	165	192	227
070	34	41	48	58	255	85	99	117	142	440	140	167	194	229
075	35	42	50	60	260	86	101	119	144	445	141	169	196	231
080	37	46	54	65	265	87	102	120	146	450	143	171	198	233
085	38	47	56	67	270	88	104	122	148	455	144	172	200	235
090	40	49	58	69	275	89	106	124	150	460	146	174	203	240
095	41	50	59	71	280	91	109	126	152	465	147	175	205	242
100	42	52	61	73	285	92	110	128	154	470	148	177	207	244
105	43	53	62	74	290	93	112	131	156	475	149	178	209	246
110	45	55	64	77	295	94	113	133	158	480	151	180	211	248
115	46	56	66	79	300	96	115	135	160	485	152	181	212	250
120	47	58	68	81	305	98	117	137	162	490	154	183	214	253
125	48	59	69	83	310	100	120	141	167	495	155	184	216	255
130	50	61	71	85	315	101	121	142	169	500	156	186	218	257
135	51	62	73	87	320	102	123	144	171	505	157	188	220	259
140	52	64	75	90	325	103	124	146	173	510	159	190	222	261
145	53	65	76	92	330	105	126	148	175	515	160	191	224	263
150	55	67	78	94	335	106	127	149	177	520	162	193	226	265
155	57	69	80	96	340	107	129	151	179	525	163	194	228	268
160	59	71	84	100	345	108	130	153	181	530	164	196	231	272
165	60	72	86	102	350	110	131	155	183	535	166	198	233	274
170	61	74	88	104	355	111	133	156	185	540	168	200	235	276
175	62	75	89	106	360	112	135	158	187	545	169	201	237	278
180	64	77	91	108	365	113	136	160	189	550	170	202	239	281
185	65	78	93	110	370	115	138	162	191	555	171	203	240	283
190	66	80	95	113	375	117	140	164	193	560	172	205	242	285
195	67	81	96	115	380	119	143	167	198	565	173	206	244	287
200	69	83	98	117	385	120	144	169	200	570	175	208	246	289
205	70	84	100	119	390	121	146	171	202	575	176	210	248	291
210	72	86	102	121	395	122	147	172	204	580	177	212	250	293
215	73	87	103	123	400	124	149	174	206	585	178	213	251	295
220	74	89	105	125	405	126	152	178	208	590	180	215	253	298
225	76	90	107	127	410	130	156	183	216	595	181	216	255	300
230	78	92	109	132	415	133	159	185	218	600	183	218	257	302

1) Weight for 1 mm sheet
0,7 mm stainless = x 0,7.

= To be assembled on site

Dimensions and weights

End connection frame LQVA

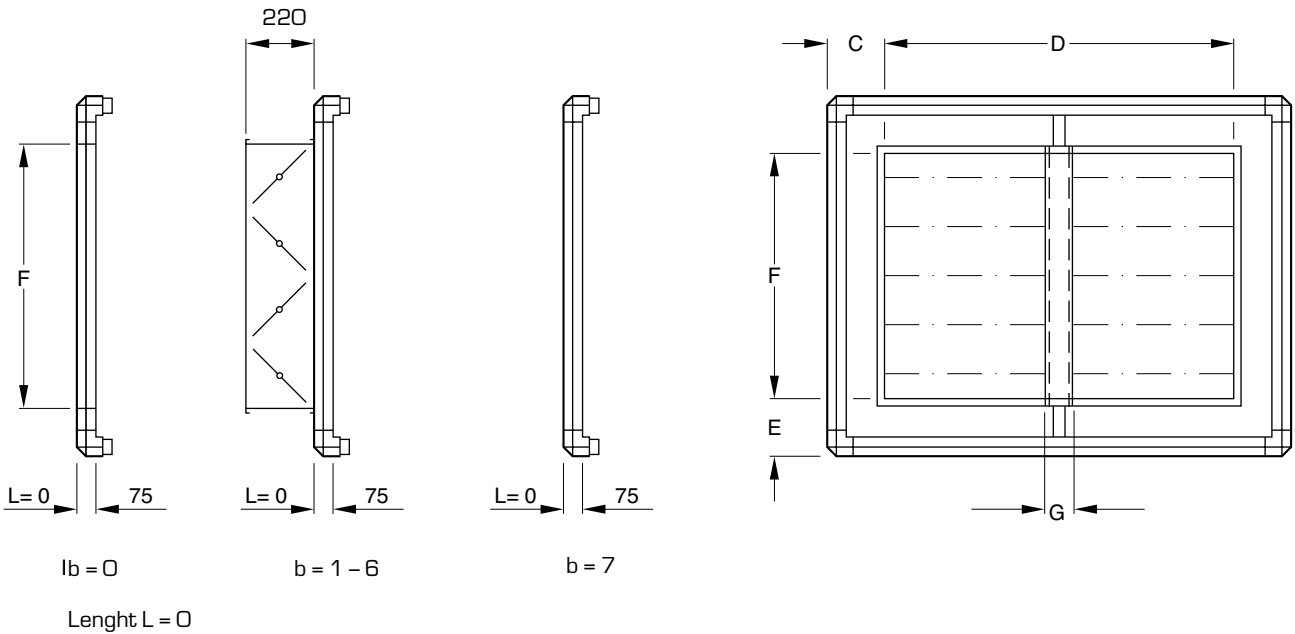

Size	C	D	E	F	G	Damper	Weight, kg		
							b = 0	b = 1-6	b = 7
60	225	1600	225	1600	-	1600 x 1600	25	80	75
62	225	2200	225	1600	200	2 x 1000 x 1600	40	115	105
64	225	2800	225	1600	200	2 x 1300 x 1600	40	135	120
71	225	2200	275	1800	200	2 x 1000 x 1800	60	145	130
73	225	2800	275	1800	200	2 x 1300 x 1800	75	180	170
80	225	2200	325	2000	200	2 x 1000 x 2000	80	175	160
82	225	2800	325	2000	200	2 x 1300 x 2000	85	205	185
84	300	3400	325	2000	200	2 x 1600 x 2000	105	255	230

Note: Sizes 62-84 have two dampers mounted side by side.

Dimensions and weights

Intake air section LQVB

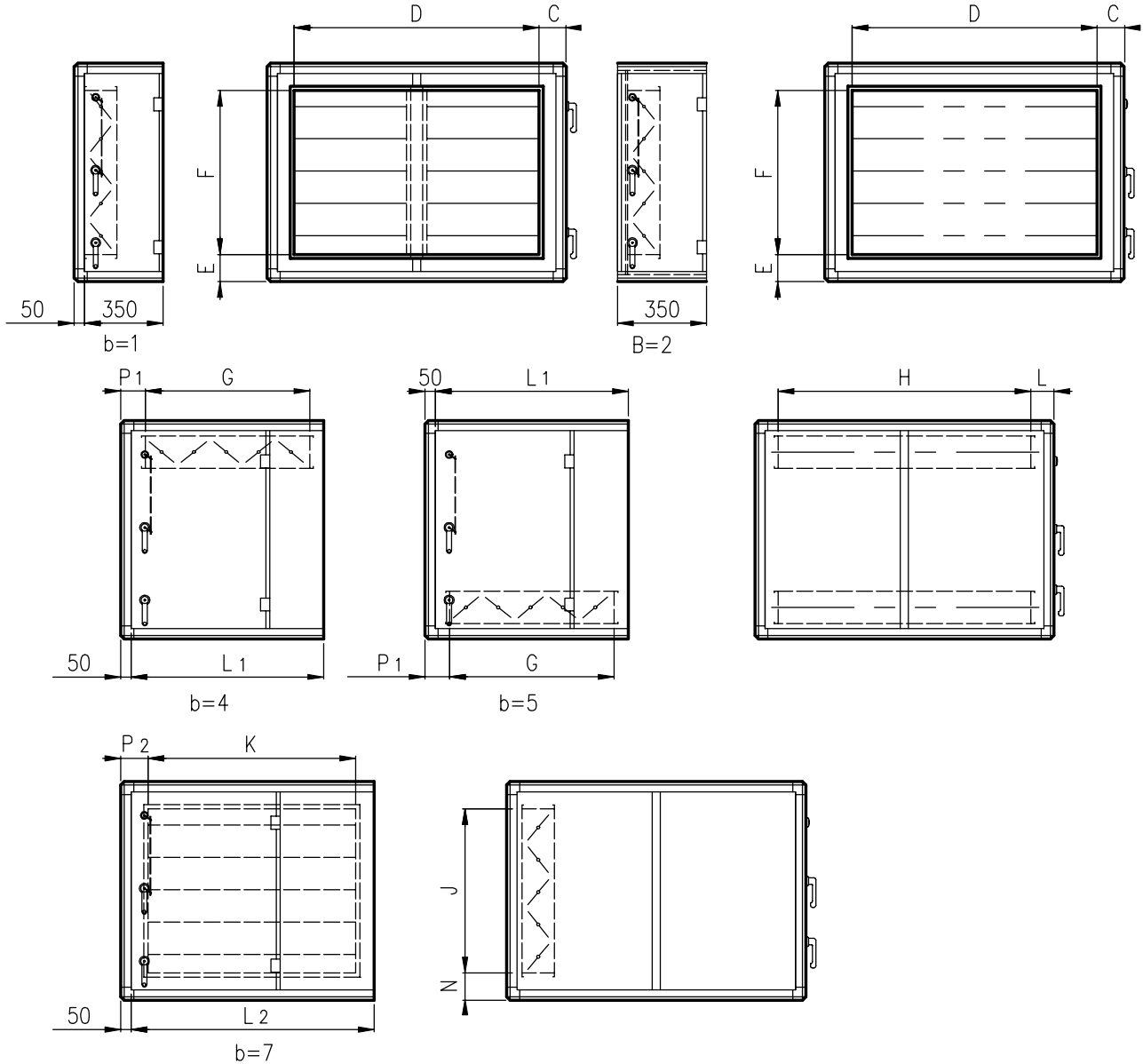

Size	C	D	E	F	G	H	L	J	K	N	L1	L2	P1	P2	Weight b=1	Weight b=2	Weight b=4,5	Weight b=7
60	225	1600	225	1600	700	1600	225	1200	1000	425	1000	1400	200	250	195	150	320	400
62	225	2200	225	1600	700	2000	325	1200	1200	425	1000	1600	200	250	245	185	390	520
64	225	2800	225	1600	700	2800	225	1200	1400	425	1000	1800	200	250	280	215	430	630
71	225	2200	275	1800	800	2000	325	1600	1200	375	1000	1600	150	250	285	205	435	590
73	225	2800	275	1800	800	2800	225	1600	1400	375	1000	1800	150	250	335	240	495	720
80	225	2200	325	2000	1000	2000	325	1800	1200	425	1200	1600	150	250	320	220	530	640
82	225	2800	325	2000	1000	2800	225	1800	1400	425	1200	1800	150	250	365	265	595	770
84	300	3400	325	2000	1000	3400	300	1800	1600	425	1200	2050	150	275	435	310	685	945

Dimensions and weights

Mixing section LQVC

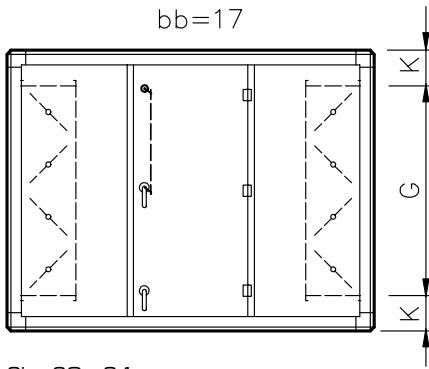

Size 60 - 84

Size	G	H	PG. J	FL. J	K	L	Weight kg
60	1200	1000	-	-	425	1400	415
62	1200	1200	-	-	425	1600	535
64	1200	1400	-	-	425	1800	640
71	1600	1200	-	-	375	1600	600
73	1600	1400	-	-	375	1800	725
80	1800	1200	-	-	425	1600	655
82	1800	1400	-	-	425	1800	790
84	1800	1600	-	-	425	2050	890

Dimensions and weights

Mixing section LQVC

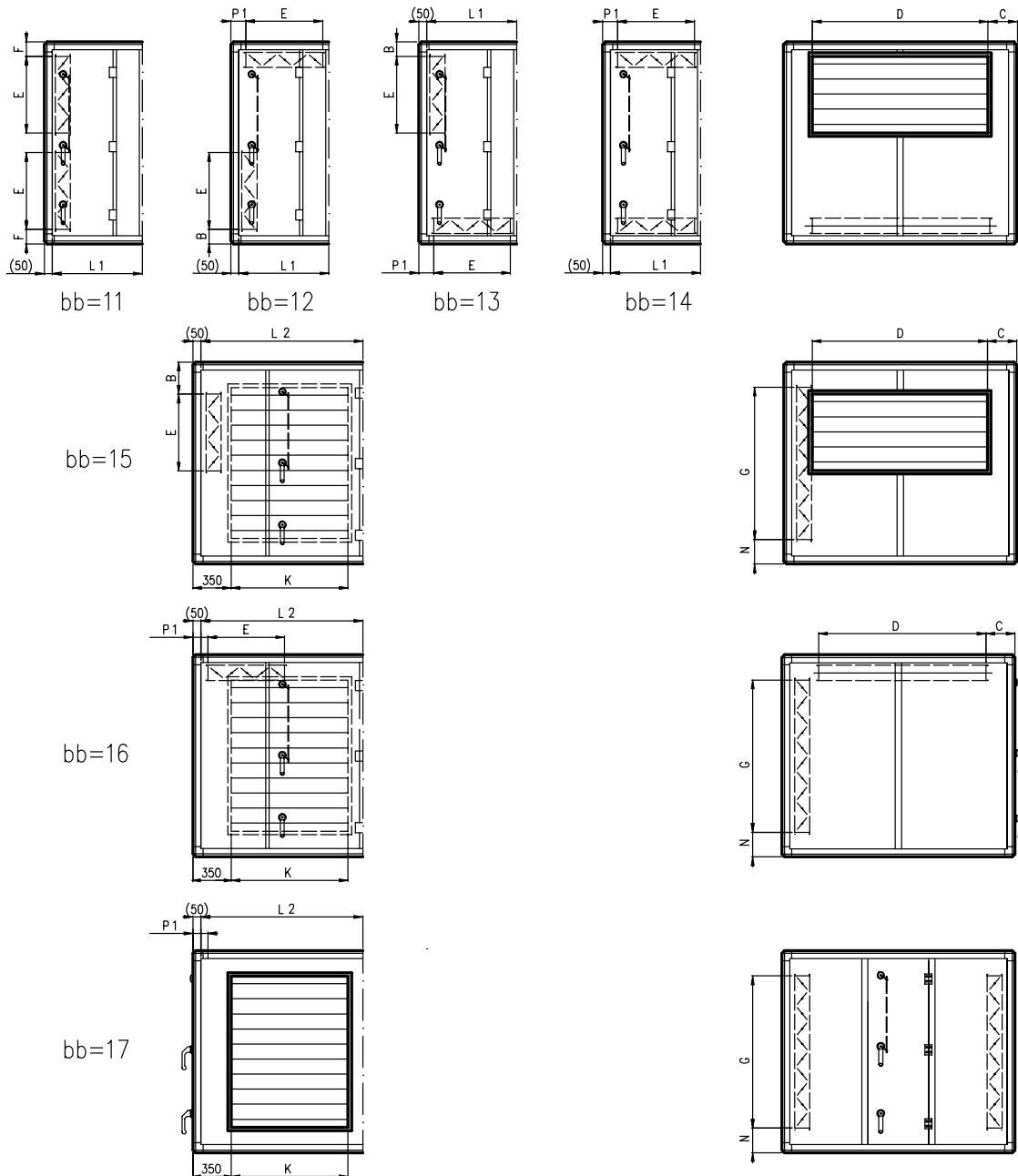

Size	B	C	D	E	F	G	K	N	L 1	L 2	P 1	Weight bb=11-14	Weight bb=15-17
60	150	225	1600	700	225	1200	1000	425	1000	1400	200	330	415
62	150	325	2000	700	225	1200	1200	425	1000	1600	200	400	535
64	150	225	2800	700	225	1200	1400	425	1000	1800	200	450	640
71	275	325	2000	800	275	1600	1200	375	1000	1600	150	440	600
73	275	225	2800	800	275	1600	1400	375	1000	1800	150	505	725
80	225	325	2000	1000	225	1800	1200	425	1200	1600	150	535	655
82	225	225	2800	1000	225	1800	1400	425	1200	1800	150	600	790
84	225	300	3400	1000	225	1800	1600	425	1200	2050	150	700	890

Dimensions and weights

Mixing and exhaust air section LQVD

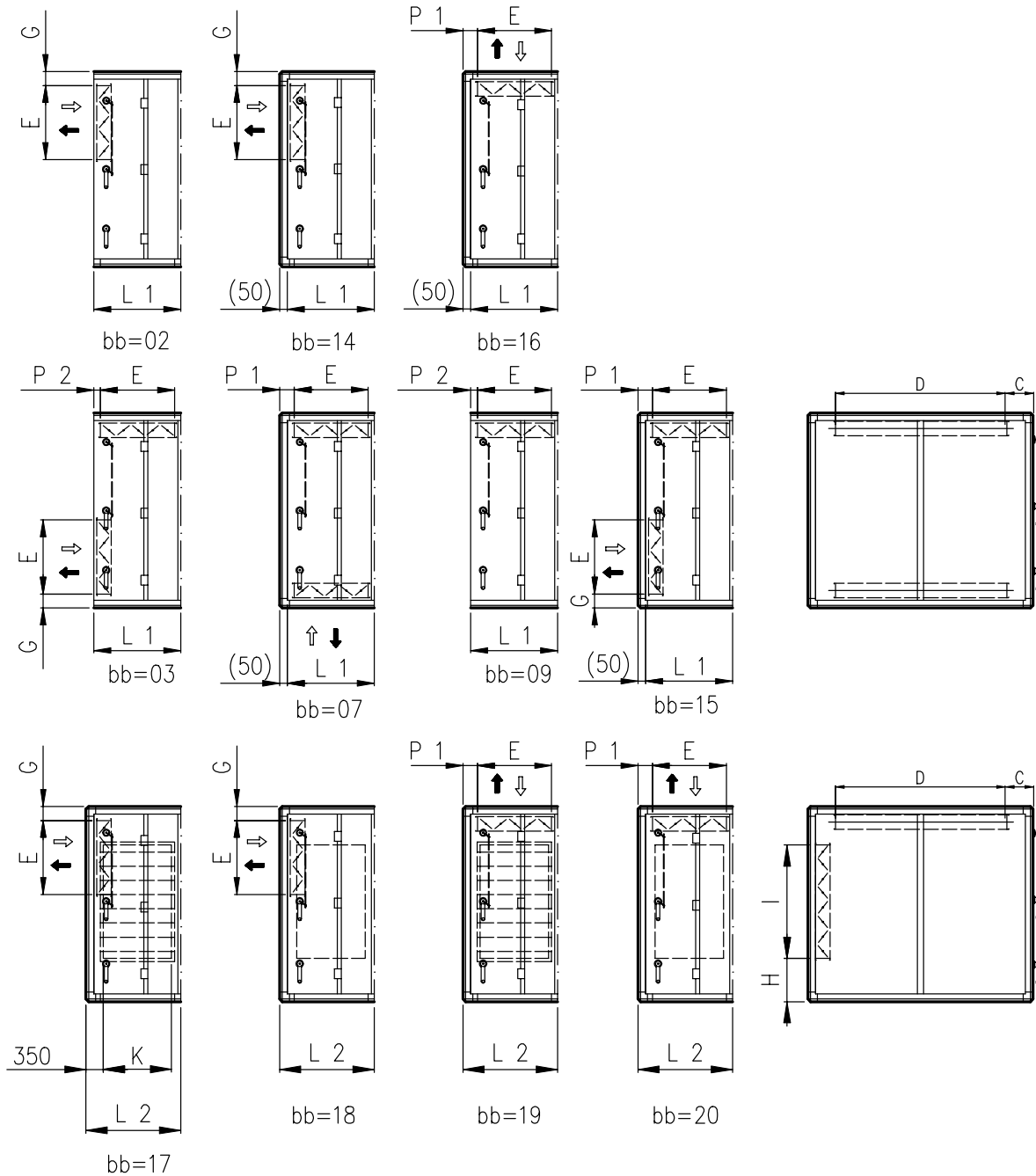

Size	C	D	E	G	H	L	K	L1	L2	P1	P2	Weight bb=0,2,09	Weight bb=14,16	Weight bb=07,15	Weight bb=03	Weight bb=17,19	Weight bb=18,20
60	225	1600	700	150	425	1200	1000	1000	1400	200	150	225	325	325	225	415	380
62	325	2000	700	150	425	1200	1200	1000	1600	200	150	255	390	390	255	535	495
64	225	2800	700	150	425	1200	1400	1000	1800	200	150	290	420	440	310	640	605
71	325	2000	800	275	375	1600	1200	1000	1600	150	100	275	430	430	275	600	555
73	225	2800	800	275	375	1600	1400	1000	1800	150	100	310	490	490	310	725	670
80	325	2000	1000	225	425	1800	1200	1200	1600	150	100	360	540	540	360	655	605
82	225	2800	1000	225	425	1800	1400	1200	1800	150	100	405	605	605	405	790	730
84	300	3400	1000	225	425	1800	1600	1200	2050	150	100	450	620	700	530	890	825

Dimensions and weights

Mixing and exhaust air section LQVD

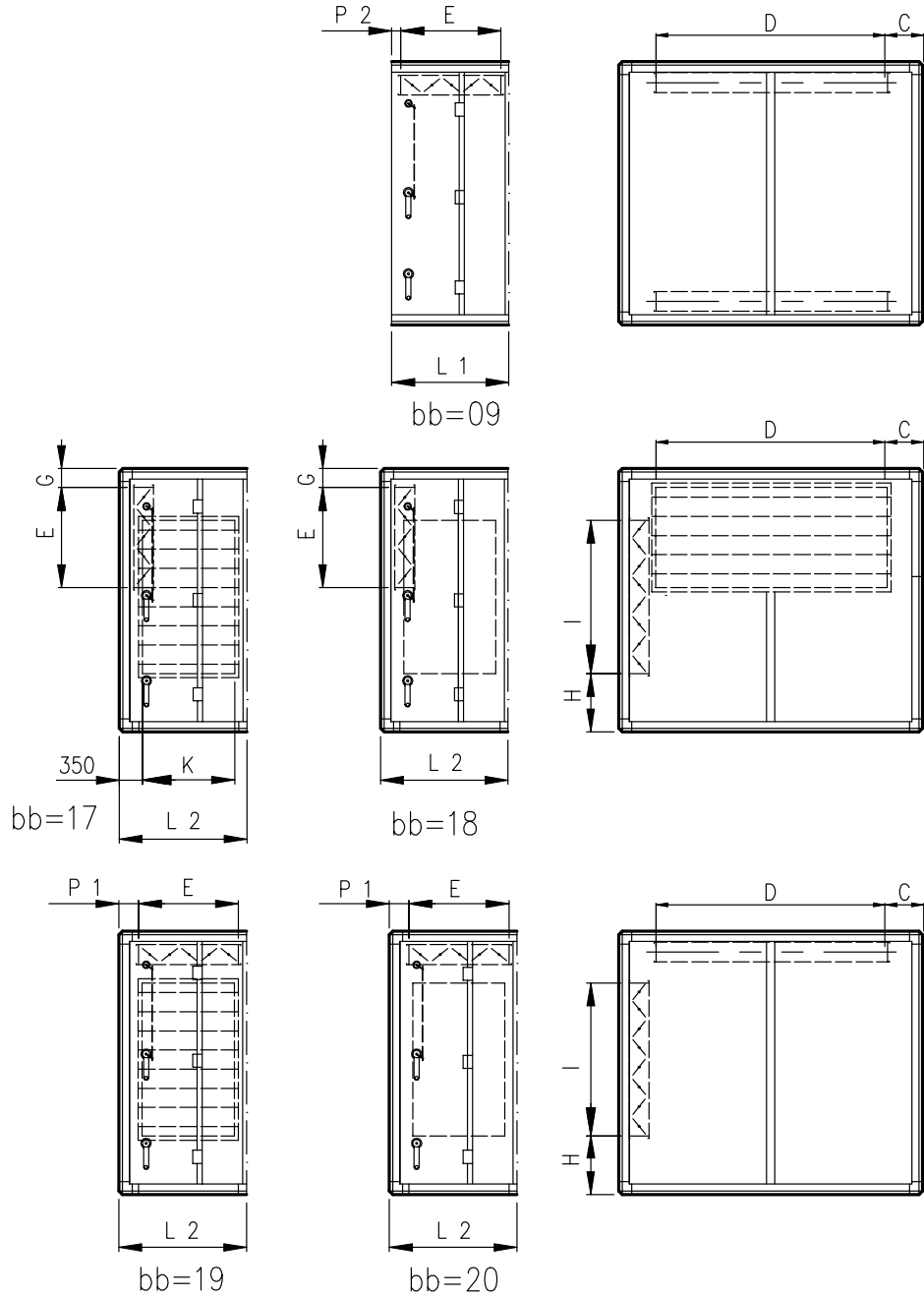

Size	C	D	E	G	H	I	K	L 1	L 2	P 1	P 2	Weight bb=09	Weight bb=17,19	Weight bb=18,20
60	225	1600	700	150	425	1200	1000	1000	1400	200	150	225	415	380
62	325	2000	700	150	425	1200	1200	1000	1600	200	150	255	535	495
64	225	2800	700	150	425	1200	1400	1000	1800	200	150	290	640	605
71	325	2000	800	275	375	1600	1200	1000	1600	150	100	275	600	555
73	225	2800	800	275	375	1600	1400	1000	1800	150	100	310	725	670
80	325	2000	1000	225	425	1800	1200	1200	1600	150	100	360	655	605
82	225	2800	1000	225	425	1800	1400	1200	1800	150	100	405	790	730
84	300	3400	1000	225	425	1800	1600	1200	2050	150	100	450	890	825

Dimensions and weights

Mixing and exhaust air section LQVD

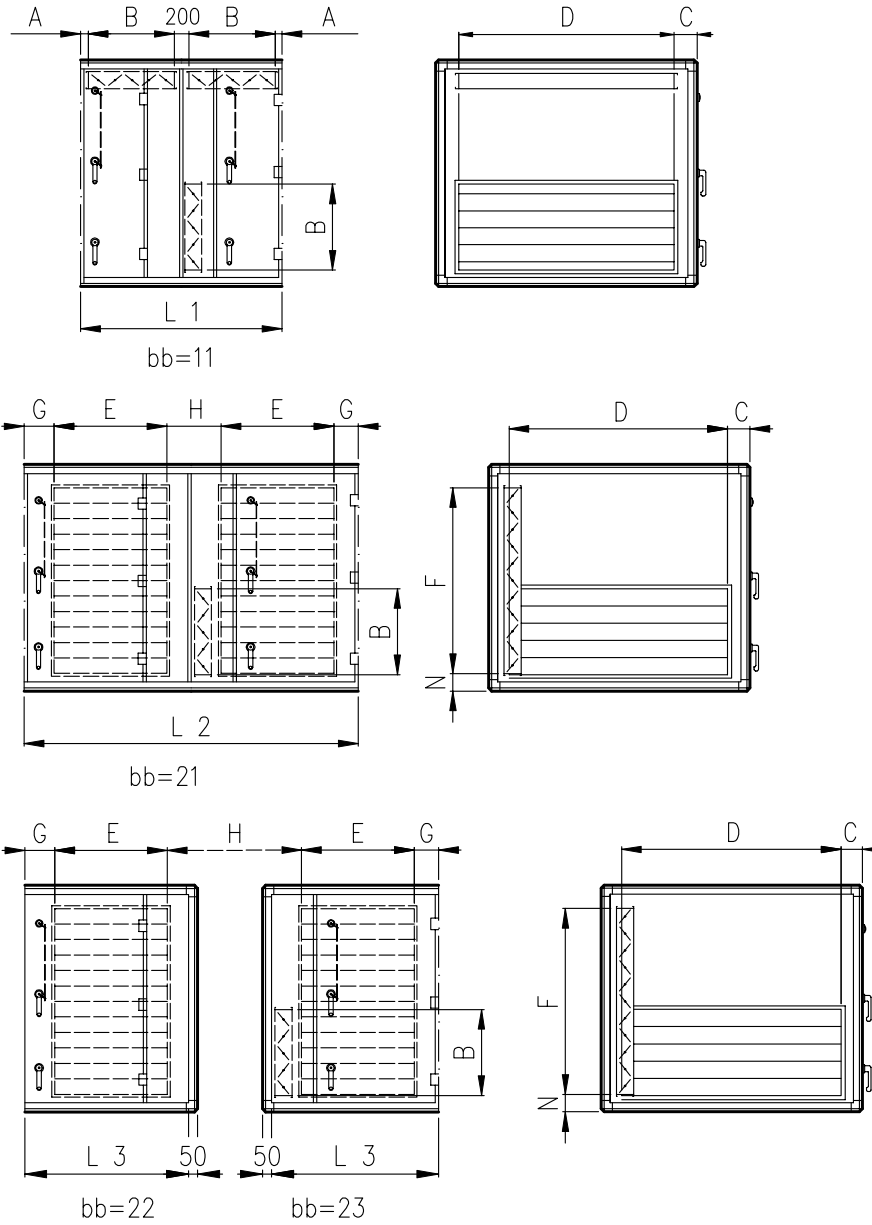

Size	A	B	C	D	E	F	G	H	N	L 1	L 2	L 3	Weight bb=11	Weight bb=21	Weight bb=22	Weight bb=23
60	200	700	225	1600	1000	1200	100	600	425	2000	2800	-	470	650	-	-
62	200	700	325	2000	1200	1200	100	600	425	2000	3200	-	550	850	-	-
64	200	700	225	2800	1400	1200	100	700	425	2000	-	1800	620	-	570	580
71	100	800	325	2000	1200	1600	100	600	375	2000	3200	-	720	930	-	-
73	100	800	225	2800	1400	1600	100	700	375	2000	-	1800	810	-	620	630
80	100	1000	325	2000	1200	1800	100	600	425	2400	3200	-	770	1000	-	-
82	100	1000	225	2800	1400	1800	100	700	425	2400	-	1800	870	-	650	660
84	100	1000	300	3400	1600	1800	150	700	425	2400	-	2050	990	-	790	800

Dimensions and weights

Intake/exhaust section LQVE (Outdoor unit)

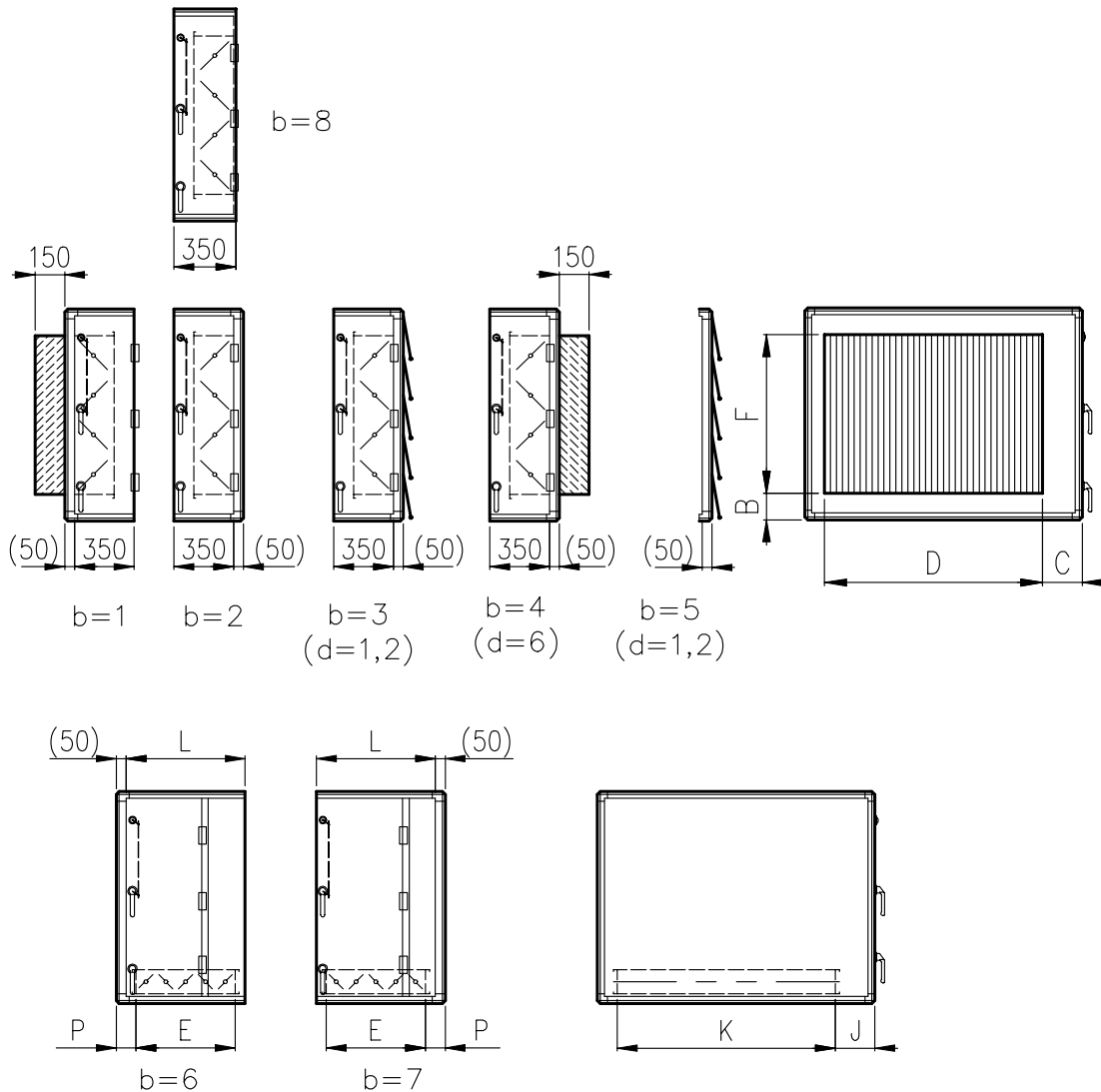

Size	B	C	D	E	F	J	K	L	p	Weight b=2,3,8	Weight b=1,4	Weight b=6,7	Weight b=5
60	225	225	1600	700	1600	225	1600	1000	200	160	190	275	30
62	325	225	2200	700	1600	325	2000	1000	200	205	245	335	40
64	225	225	2800	700	1600	225	2800	1000	200	235	285	375	55
71	275	225	2200	800	1800	325	2000	1000	150	240	285	380	60
73	275	225	2800	800	1800	225	2800	1000	150	290	345	435	85
80	325	225	2200	1000	2000	325	2000	1200	150	275	325	470	80
82	325	225	2800	1000	2000	225	2800	1200	150	320	385	530	105
84	325	300	3400	1000	2000	300	3400	1200	150	385	460	615	120

Dimensions and weights

Mixing section LQVF (Outdoor unit)

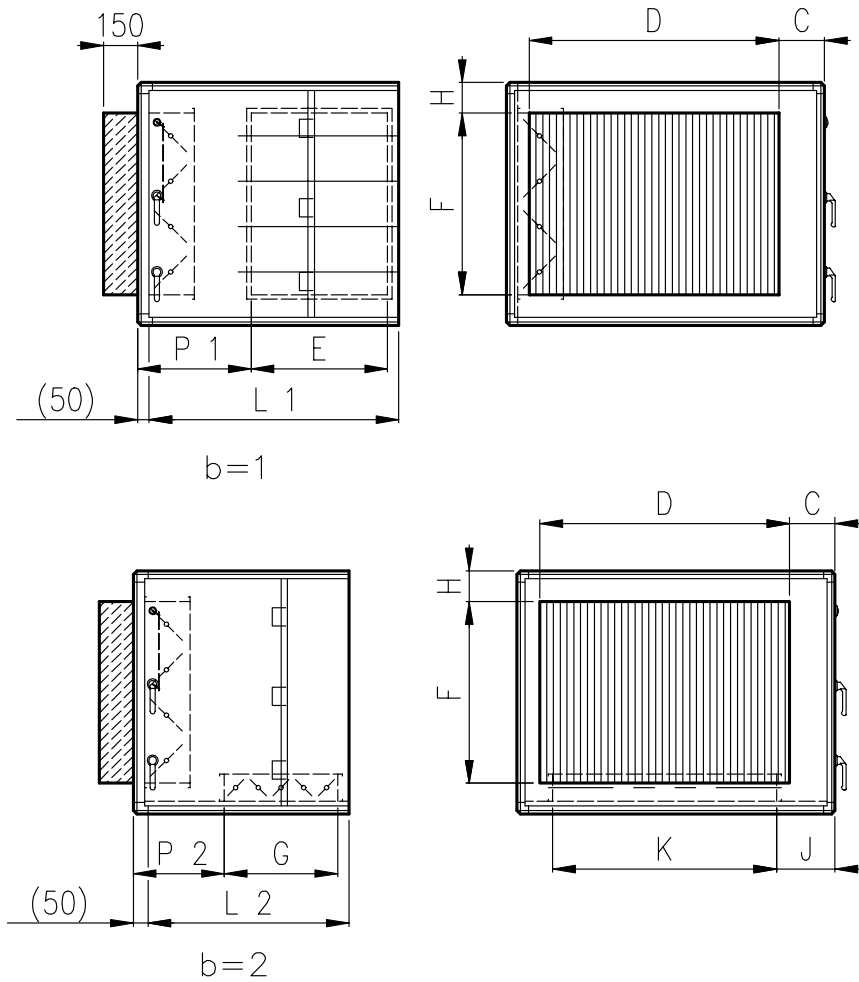

Size	A	D	E	F	G	H	J	K	L 1	L 2	P 1	P 2	Weight b=1	Weight b=2
60	225	1600	1000	1600	700	225	225	1600	1400	1200	350	425	390	350
62	225	2200	1200	1600	700	225	325	2000	1600	1200	350	425	520	430
64	225	2800	1400	1600	700	225	225	2800	1800	1200	350	425	635	485
71	225	2200	1200	1800	800	275	325	2000	1600	1200	375	325	580	480
73	225	2800	1400	1800	800	275	225	2800	1800	1200	375	325	720	560
80	225	2200	1200	2000	1000	325	325	2000	1600	1400	375	325	635	580
82	225	2800	1400	2000	1000	225	225	2800	1800	1400	375	325	775	660
84	300	3400	1600	2000	1000	325	300	3400	2050	1400	375	325	970	770

Dimensions and weights

Blandnings- och frånluftsdel LQVG (Utomhusutförande)

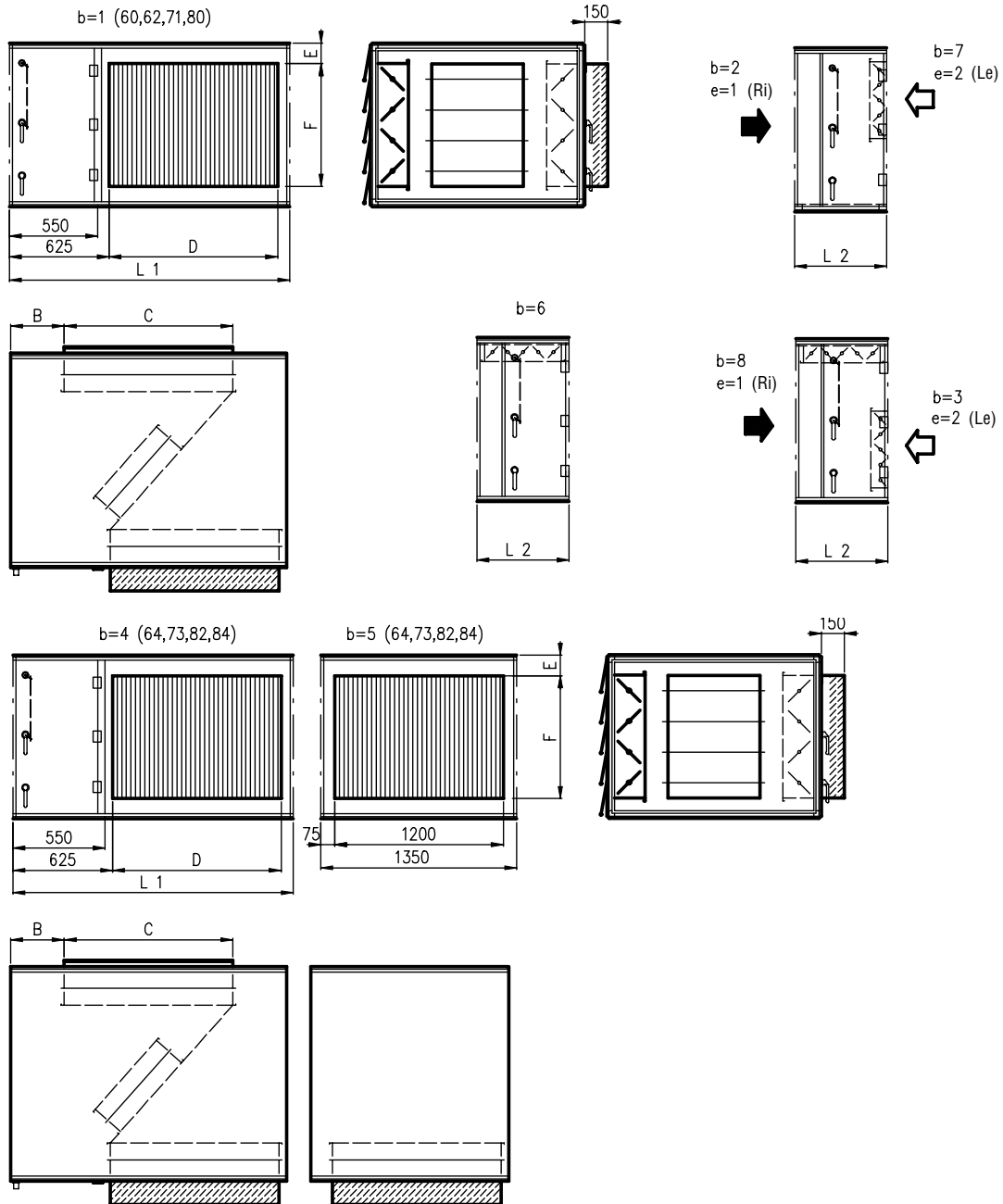

Size	B	C	D	E	F	L 1	L 2	Weight b=1	Weight b=2,7	Weight b=3,8	Weight b=5	Weight b=5	Weight b=5
60	650	1000	1600	225	1600	2300	1000	520	210	235	-	-	225
62	850	1200	2200	225	1600	2900	1000	735	240	275	-	-	255
64	450	1400	1600	225	1600	2300	1000	-	260	305	625	360	290
71	850	1200	2200	275	1800	2900	1000	785	260	305	-	-	275
73	450	1400	1600	275	1800	2300	1000	-	275	325	665	385	310
80	850	1200	2200	325	2000	2900	1200	835	315	365	-	-	290
82	450	1400	1600	325	2000	2300	1200	-	350	430	705	405	325
84	650	1600	2200	325	2000	2900	1200	-	360	440	985	450	370

Dimensions and weights

Filter section LQP(A,C)

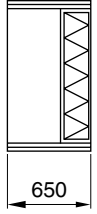
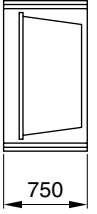
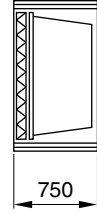
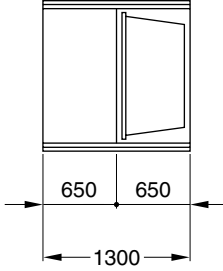
	LQPA	LQPC d = 0 f = 1 Without Prefilter	LQPC d = 1 f = 1 With Prefilter	LQPC d = 0 f = 4, 5 Without Prefilter
				
	650	750	750	650 650 1300
Size	Weight, kg	Weight, kg	Weight, kg	Weight, kg e = 1
60	175	195	220	305
62	205	230	260	355
64	250	260	300	395
71	235	255	295	385
73	275	290	335	435
80	250	270	310	405
82	290	305	350	460
84	330	350	410	520

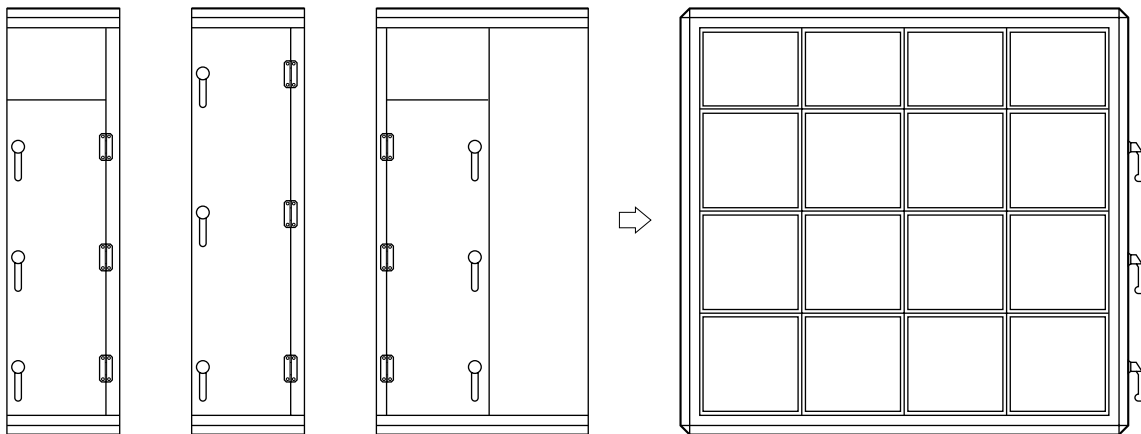

LQPA

LQPC
f = 1

LQPC
f = 4, (positive pressure)
f = 5, (negative pressure), d = 0

Dimensions and weights

Absolute filter LQPF

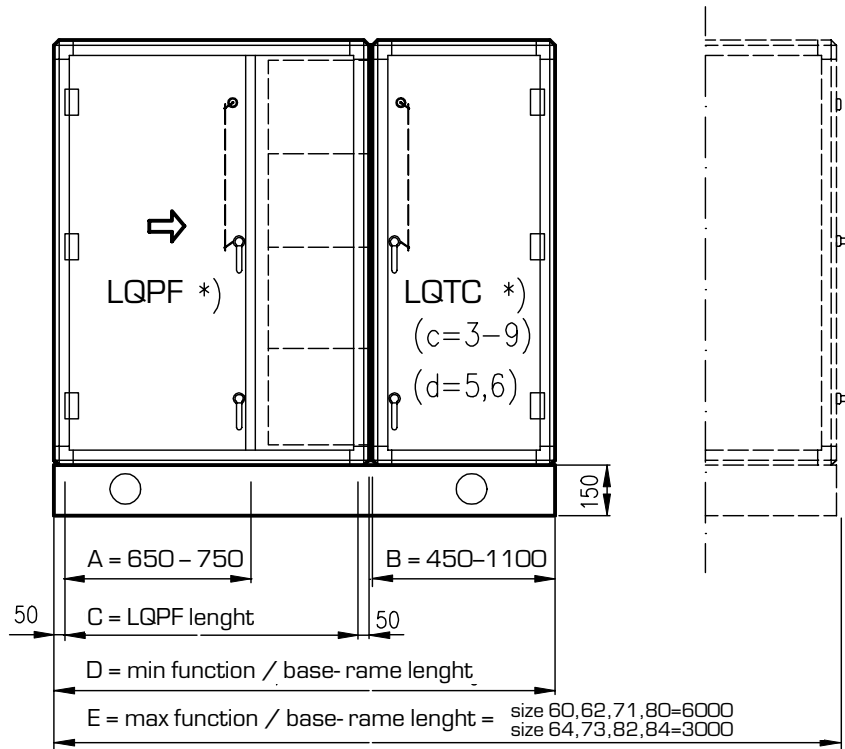

LQPF Size	bb=09	bb=10	bb=11	bb=12
	A=650 C=900 Wgt. kg	A=750 C=1000 Wgt. kg	A=750 C=1100 Wgt. kg	A=750 C=1200 Wgt. kg
60	357	377	397	417
62	439	462	484	507
64	514	539	563	588
71	498	522	546	570
73	582	608	634	660
80	541	566	591	617
82	632	659	687	715
84	749	780	811	842

Pos. pressure (c=1) Lenght D	Neg. pressure (c=1) Lenght D
1658 - 2408	1458 - 2408

Filter set LQPZ-24 Size bb	Weight, kg
60	165
62	220
64	260
71	270
73	300
80	280
82	325
84	395

Dimensions and weights

Carbon filter LQPK

Size 60 – 84

Size	Weight, kg b=0	Weight, kg b=1
60	180	620
62	215	780
64	235	960
71	225	900
73	250	1100
80	245	1015
82	275	1255
84	320	1490

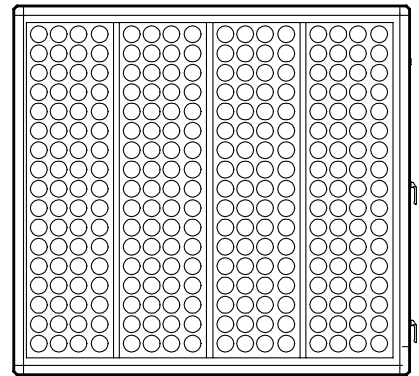
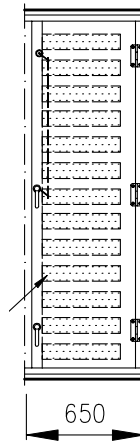

Dimensions and weights

Air heater LQE(E,V) (e = 4)

Size 60-64 (b = 1-4, d = 1), Size 60-73 (b = 5, d = 1)

Conn. No. (1/4" BSP) female pipe thread

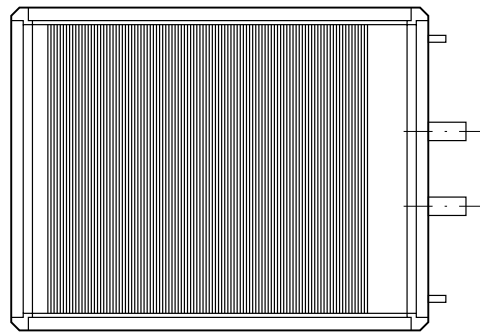
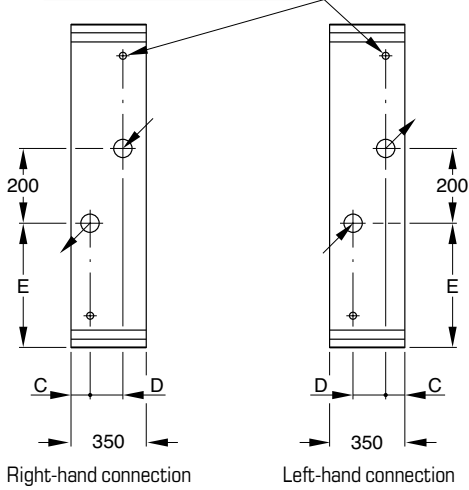

Single coil version shown.

Connections have male threads. See accessories for details of flanges. Connection tolerance is ± 4 mm.

Storlek 60 - 84 (d = 2), storlek 80 - 84 (b = 5)

Ansl. nr. (1/4" BSP) inv. rörgänga

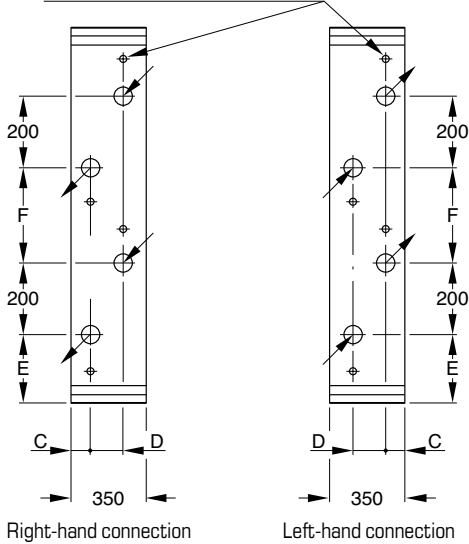

Size	Weight, kg Cu/Al Output variant			Weight, kg Cu/Cu Output variant		
	1,2	3,4	5	1,2	3,4	5
60	170	205	235	205	275	340
62	235	250	295	250	340	425
64	235	295	350	300	410	510
71	215	265	315	270	370	465
73	250	310	375	315	440	555
80	235	295	355	300	420	535
82	270	350	420	355	500	640
84	320	415	505	420	600	775

Size	Output variant 1, 2							
	C	D	Volume, L	One coil		Splitted coil		
				E	Ansl. nr	E	F	Nom. Pipe
60	130	68	19	925	50	525	605	50
62	130	68	23	925	50	525	605	50
64	130	68	27	925	50	525	605	50
71	130	68	26	1075	50	625	705	50
73	130	68	30	1075	50	625	705	50
80	130	68	32	1225	50	675	905	50
82	130	68	37	1225	50	675	905	50
84	130	68	43	1225	50	675	905	50

Size	Output variant 3, 4										Output variant 5									
	C	Volume, L	D	One coil			Splitted coil				C	Volume, L	D	One coil			Splitted coil			
				E	Nom. Pipe	D	E	F	Nom. Pipe	E				F	Nom. Pipe.	D	E	F	Nom. Pipe	
LQEE 60	130	31	68	925	50	68	525	605	50	130	42	94	925	-	80	68	525	605	50	
LQEV 60	130	41	94	925	80	68	525	605	50	130	52	94	925	-	80	94	525	605	80	
62	130	38	94	925	80	68	525	605	50	130	63	94	925	-	80	94	525	605	80	
64	130	46	94	925	80	68	525	605	50	130	75	94	925	-	80	94	525	605	80	
71	130	54	94	1075	80	68	625	705	50	130	71	94	1075	-	80	94	625	705	80	
73	130	63	94	1075	80	68	625	705	50	130	84	94	1075	-	80	94	625	705	80	
80	130	66	94	1225	80	94	625	905	80	130	88	94	675	900	2x80	94	675	905	80	
82	130	77	94	1225	80	94	625	905	80	130	104	94	675	900	2x80	94	675	905	80	
84	130	90	94	1225	80	94	625	905	80	130	125	94	675	900	2x80	94	675	905	80	

Dimensions and weights

Frost coil LQEG

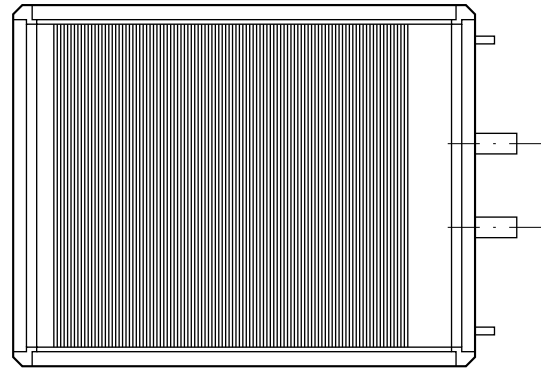
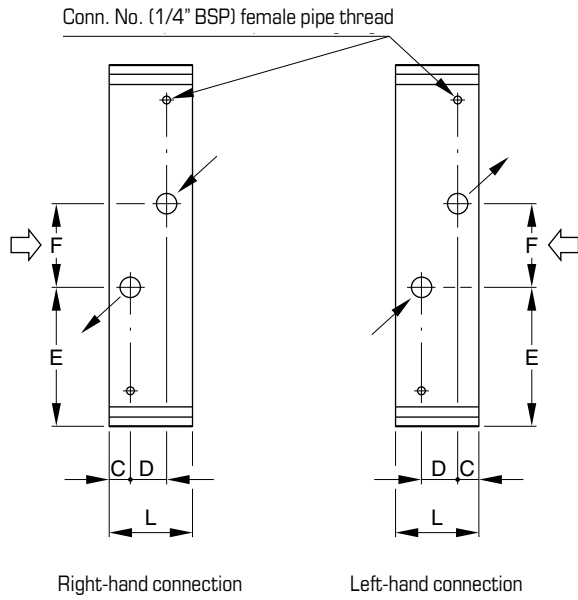

Connections have male threads.
See accessories for details of flanges.
Connection tolerance is ± 4 mm.

Size	L	Weight, kg		bb = 01, 04		bb = 02, 03		E	F	Nom. Pipe	Volume, L
		bb = 00	bb = 01-04	C	D	C	D				
60	250	100	125	105	68	105	68	925	200	50	21
62	250	120	145	105	68	105	68	925	200	50	26
64	250	130	165	105	68	105	68	925	200	50	30
71	250	130	160	105	68	105	68	1075	200	50	29
73	250	150	190	105	68	105	68	1075	200	50	34
80	250	150	185	105	68	105	68	1225	200	50	34
82	250	160	205	105	68	105	68	1225	200	50	40
84	250	185	240	105	68	105	68	1225	200	50	47

Dimensions and weights

Air heater electric LQEK (low temp.)

Right-hand connection side

Left-hand connection side

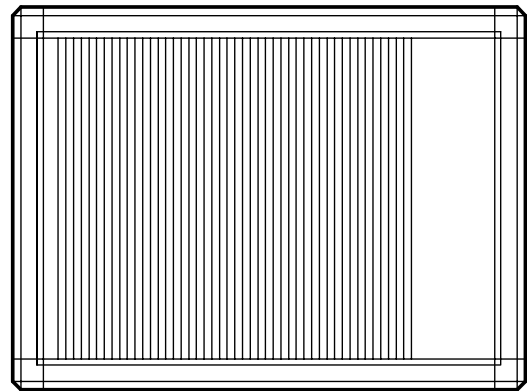
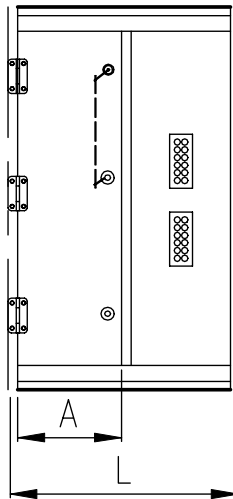
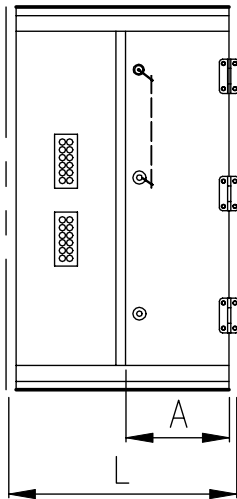

Output variant	L	A
1-3	500	200
4	700	400

Size	Weight, kg			
	1	2	3	4
60	235	270	305	380
62	290	340	385	480
64	345	405	465	570
71	330	385	440	540
73	390	460	530	650
80	365	430	490	605

Size	Output variant	Capacity kw	Capacity steps, kW								Face area m ²	Min. airflow low temp. m ³ /s
			H	K	L	M	N	O	P	R		
60	1	60	2,5	2,5	5	10	20	20			3,1	6,1
	2	120	5	5	10	20	40	40				
	3	240	10	10	20	(5 steps x 40 kw)						
	4	320	10	10	20	(7 steps x 40 kw)						
62	1	84	3,5	3,5	7	14	28	28			4,2	8,3
	2	168	7	7	14	(5 steps x 28 kw)						
	3	336	14	14	(11 steps x 28 kw)							
	4	448	14	14	(15 steps x 28 kw)							
64	1	96	4	4	8	16	32	32			5,3	10,4
	2	192	8	8	16	(5 steps x 32 kw)						
	3	384	16	16	(11 steps x 32 kw)							
	4	512	16	16	(15 steps x 32 kw)							
71	1	96	4	4	8	16	32	32			4,8	9,6
	2	192	8	8	16	(5 steps x 32 kw)						
	3	384	16	16	(11 steps x 32 kw)							
	4	512	16	16	(15 steps x 32 kw)							
73	1	120	5	5	10	20	40	40			6,0	12,0
	2	240	10	10	20	(5 steps x 40 kw)						
	3	480	20	20	(11 steps x 40 kw)							
	4	640	20	20	(15 steps x 40 kw)							
80	1	108	4,5	4,5	9	18	36	36			5,5	11,0
	2	216	9	9	18	(5 steps x 36 kw)						
	3	432	18	18	(11 steps x 36 kw)							
	4	576	18	18	(15 steps x 36 kw)							

Dimensions and weights

Air heater electric LQEK (high temp.)

Right-hand connection side

Left-hand connection side

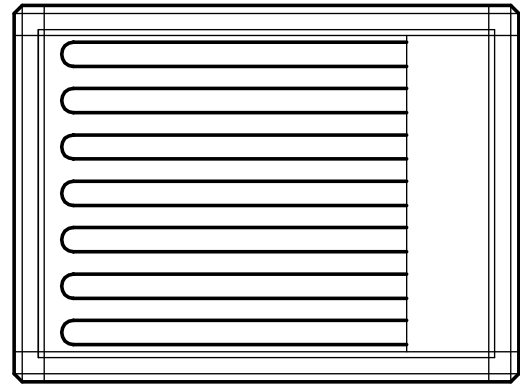
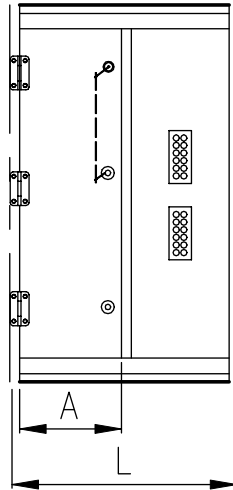
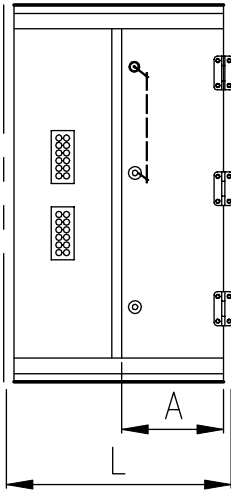

Size	Output variant	Capacity kw	Capacity steps, kw								Face area m ²	Min. airflow low temp. m ³ /s	L	A	Weight, kg	
			H	K	L	M	N	O	P	R						
60	1	60	2,5	2,5	5	10	20	20			3,1	6,1	500	200	165	
	2	120	5	5	10	20	40	40					500	200	200	
	3	240	10	10	20	(5 steps x 40 kw)								500	200	235
	4	320	10	10	20	(7 steps x 40 kw)								700	400	310
62	1	84	3,5	3,5	7	14	28	28			4,2	8,3	500	200	200	
	2	168	7	7	14	(5 steps x 28 kw)								500	200	245
	3	336	14	14		(11 steps x 28 kw)								500	200	295
	4	448	14	14		(15 steps x 28 kw)								700	400	385
64	1	96	4	4	8	16	32	32			5,3	10,4	700	400	280	
	2	192	8	8	16	(5 steps x 32 kw)								700	400	340
	3	384	16	16		(11 steps x 32 kw)								700	400	400
	4	512	16	16		(15 steps x 32 kw)								700	400	460
71	1	96	4	4	8	16	32	32			4,8	9,6	500	200	220	
	2	192	8	8	16	(5 steps x 32 kw)								500	200	275
	3	384	16	16		(11 steps x 32 kw)								500	200	330
	4	512	16	16		(15 steps x 32 kw)								700	400	435
73	1	120	5	5	10	20	40	40			6,0	12,0	700	400	310	
	2	240	10	10	20	(5 steps x 40 kw)								700	400	380
	3	480	20	20		(11 steps x 40 kw)								700	400	445
	4	640	20	20		(15 steps x 40 kw)								700	400	315
80	1	108	4,5	4,5	9	18	36	36			5,5	11,0	500	200	240	
	2	216	9	9	18	(5 steps x 36 kw)								500	200	305
	3	432	18	18		(11 steps x 36 kw)								500	200	370
	4	576	18	18		(15 steps x 36 kw)								700	400	480
82	1	120	5	5	10	20	40	40			6,2	9,3	700	400	335	
	2	240	10	10	20	(5 steps x 40 kw)								700	400	415
	3	480	20	20		(11 steps x 40 kw)								700	400	500
	4	640	20	20		(15 steps x 40 kw)								700	400	570

Dimensions and weights

Air heater for steam LQES

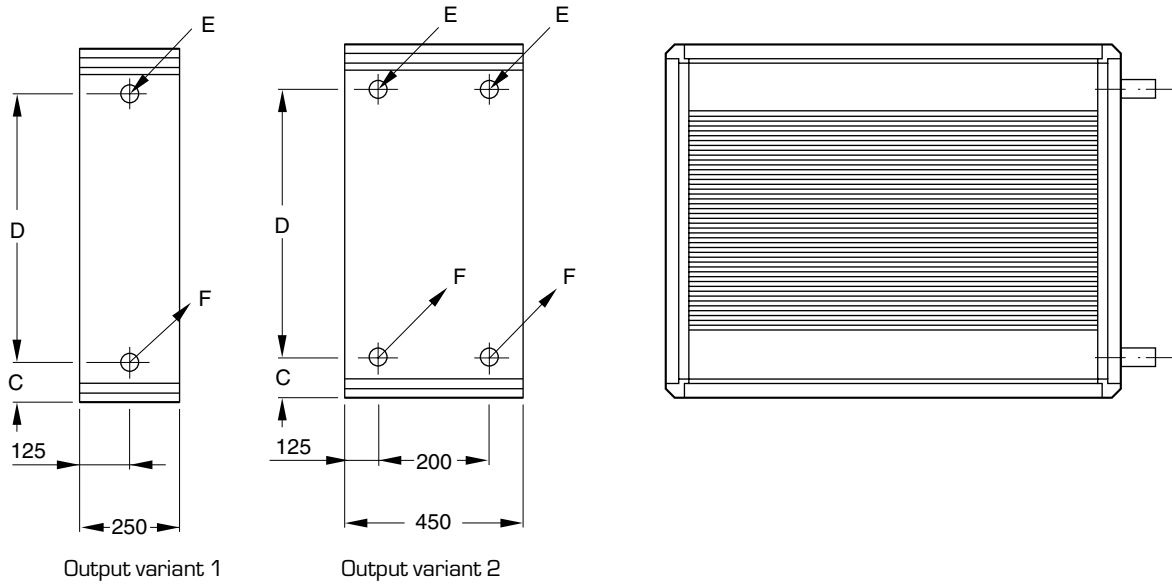

Right- or left-hand connection side.

Size	C Output variant		D Output variant		Nom. pipe size ¹⁾		Weight, kg with Fe/AL Output variant	
	1	2	1	2	E	F	1	2
60	180	180	1675	1675	80	50	200	385
62	180	180	1675	1675	80	50	245	475
64	180	180	1675	1675	80	50	290	565
71	197	197	1940	1940	80	50	270	520
73	197	197	1940	1940	80	50	315	615
80	180	180	2275	2275	80	50	295	580
82	195	195	2245	2245	100	80	350	695
84	195	195	2245	2245	100	80	410	820

1) Connections have male threads.
See accessories for details of flanges.
Connection tolerance is ± 4 mm.

Dimensions and weights

Air cooler for chilled water LQNN

Normal coupling d = 1-3

Short coupling d = 6-8

Size 60-84

Output variant	L
2	550
3	550
4	550
5	650

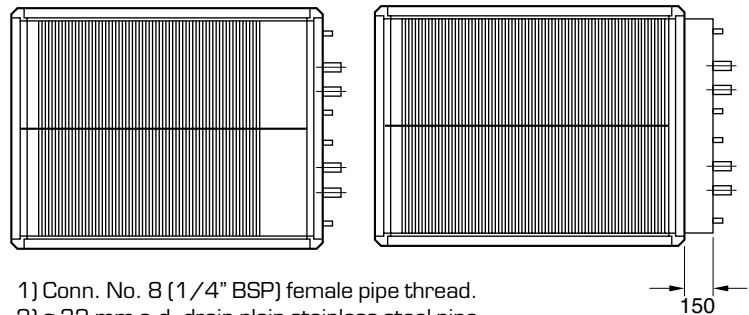
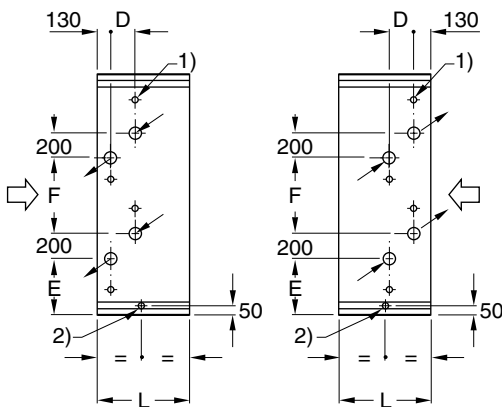

1) Conn. No. 8 (1/4" BSP) female pipe thread.
2) ø 32 mm o.d. drain plain stainless steel pipe.

Output variant 2

Size	Output variant 2							Volume, L	Wgt. kg Cu/Al
	Normal coupling d=1-3			Short coupling d=6-8					
	Conn.	D		Conn.	D	E	F		
60	50	68		80	94	939	-	35	330
62	50	68		80	94	939	-	44	410
64	80	94		80	94	939	-	64	490
71	80	94		80	94	1072	-	50	470
73	80	94		80	94	1072	-	74	560
80	80	94		80	94	1239	-	58	520
82	80	94		80	94	1239	-	86	620
84	80	94		80	94	1239	-	100	740

Output variant 3

Size	Output variant 3								Volume, L	Wgt. kg Cu/Al
	Normal coupling d=1-3			Short coupling d=6-8						
	Conn.	E	F	Conn.	D	E	F			
60	80	939	-	2 x 80	94	489	700	60	370	
62	80	939	-	2 x 80	94	489	700	73	460	
64	2 x 80	489	700	2 x 80	94	489	700	86	550	
71	80	1072	-	2 x 80	94	555	833	70	530	
73	2 x 80	555	833	2 x 80	94	555	833	98	630	
80	80	1239	-	2 x 80	94	639	1000	82	590	
82	2 x 80	639	1000	2 x 80	94	639	1000	114	710	
84	2 x 80	639	1000	2 x 80	94	639	1000	136	850	

Output variant 4

Size	Output variant 4								Volume, L	Wgt. kg Cu/Al
	Normal coupling d=1-3			Short coupling d=6-8						
	Conn.	E	F	Conn.	D	E	F			
60	80	939	-	2 x 80	101	489	700	73	410	
62	80	939	-	2 x 80	101	489	700	90	510	
64	2 x 80	489	700	2 x 80	101	489	700	108	610	
71	80	1072	-	2 x 80	101	1072	833	104	590	
73	2 x 80	555	833	2 x 80	101	555	833	122	710	
80	80	1239	-	2 x 80	101	1239	1000	120	660	
82	2 x 80	639	1000	2 x 80	101	639	1000	144	790	
84	2 x 80	639	1000	2 x 80	101	639	1000	172	950	

Output variant 6

Size	Output variant 6								Volume, L	Wgt. kg Cu/Al
	Normal coupling d=1-3			Short coupling d=6-8						
	Conn.	E	F	Conn.	D	E	F			
60	80	939	-	2 x 80	144	489	700	99	510	
62	80	939	-	2 x 80	144	489	700	125	640	
64	2 x 80	489	700	2 x 80	144	489	700	151	770	
71	80	1072	-	2 x 80	144	555	833	142	750	
73	2 x 80	555	833	2 x 80	144	555	833	172	900	
80	80	1239	-	2 x 80	144	639	1000	166	830	
82	2 x 80	639	1000	2 x 80	144	639	1000	200	1010	
84	2 x 80	639	1000	2 x 80	144	639	1000	244	1210	

Connections have male threads.
See accessories for details of flanges.
Connection tolerance is ±4 mm.

Dimensions and weights

Air cooler for chilled water LQNN with split coil

Normal coupling d = 1–3

Short coupling d = 6–8

Output variant	Size 60-84
2	550
3	550
4	550
5	650

Output variant 2

Size	Output variant 2							Weight, kg	
	Normal coupling d=1-3		Short coupling d=6-8		E	F	Volume, L	ee=01,04 Cu/Al	ee=02,03 Cu/Cu
	Conn.	D	Conn.	D					
60	50	68	50	68	489	704	35	330	455
62	50	68	50	68	489	704	44	410	575
64	50	68	50	68	489	704	64	490	690
71	50	68	80	94	556	837	50	470	665
73	80	94	80	94	556	837	74	560	800
80	50	68	80	94	639	1004	58	520	740
82	80	94	80	94	639	1004	86	620	890
84	80	94	80	94	639	1004	100	740	1065

Output variant 3

Size	Output variant 3							Weight, kg	
	Normal coupling d=1-3		Short coupling d=6-8		E	F	Volume, L	ee=01,04 Cu/Al	ee=02,03 Cu/Cu
	Conn.	D	Conn.	D					
60	50	68	80	94	489	704	60	370	440
62	50	68	80	94	489	704	73	460	545
64	80	94	80	94	489	704	86	550	645
71	50	68	80	94	556	837	70	530	625
73	80	94	80	94	556	837	98	630	740
80	50	68	80	94	639	1004	82	590	695
82	80	94	80	94	639	1004	114	710	835
84	80	94	80	94	639	1004	135	850	1000

Connections have male threads.
See accessories for details of flanges.
Connection tolerance is ± 4 mm.

Output variants 4 and 6, see next page.

Dimensions and weights

Air cooler for chilled water LQNN with split coil

Normal coupling d = 1–3

Short coupling d = 6–8

Output variant 4

Size	Output variant 4							Weight, kg	
	Normal coupling d=1-3		Short coupling d=6-8		E	F	Volume, L	ee=01,04 Cu/Al	ee=02,03 Cu/Cu
	Conn.	D	Conn.	D					
60	50	87	80	101	489	704	73	410	505
62	50	87	80	101	489	704	90	510	630
64	80	101	80	101	489	704	108	610	755
71	80	101	80	101	556	837	104	590	730
73	80	101	80	101	556	837	122	710	885
80	80	101	80	101	639	1004	120	660	820
82	80	101	80	101	639	1004	144	790	980
84	80	101	80	101	639	1004	172	950	1180

Output variant 6

Size	Output variant 6							Weight, kg	
	Normal coupling d=1-3		Short coupling d=6-8		E	F	Volume, L	ee=01,04 Cu/Al	ee=02,03 Cu/Cu
	Conn.	D	Conn.	D					
60	50	144	80	144	489	704	99	510	615
62	50	144	80	144	489	704	125	640	770
64	80	144	80	144	489	704	151	770	930
71	80	144	80	144	556	837	142	750	905
73	80	144	80	144	556	837	172	900	1085
80	80	144	80	144	639	1004	166	830	1000
82	80	144	80	144	639	1004	200	1010	1225
84	80	144	80	144	639	1004	244	1210	1465

Connections have male threads.
See accessories for details of flanges.
Connection tolerance is ± 4 mm.

Dimensions and weights

Air cooler for evaporative refrigerant LQNP with split coil

Size 60-80
c = 3, 4 g = 0, 1 f = 1

Size 60-80
c = 3, 4 g = 0, 1 f = 2

Right-hand connection side

Left-hand connection side

Right-hand connection side

Left-hand connection side

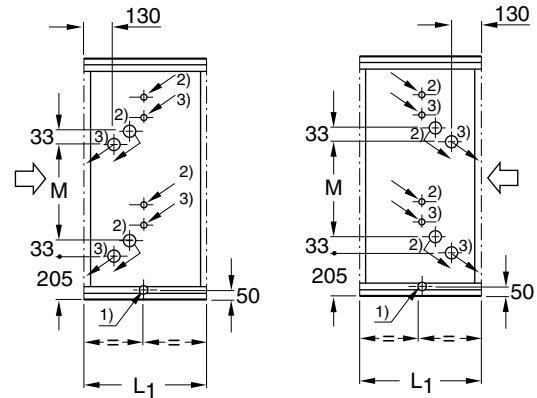
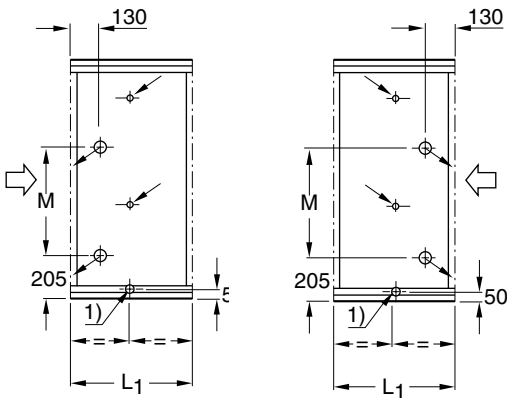

Normal frontarea c = 1,3

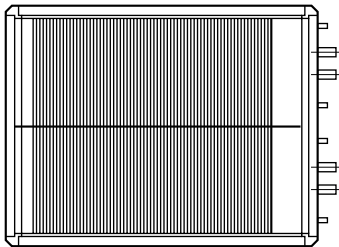

Max. frontarea c = 2,4

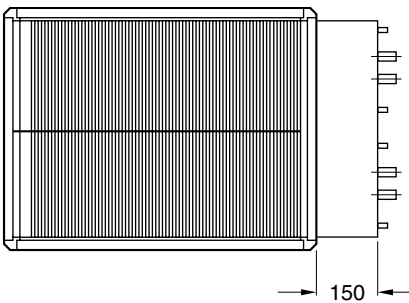

- 1) \varnothing 32 mm o.d. drain plain, stainless steel pipe
- 2) Connection for stage 1/3
- 3) Connection for stage 2/3

With drawable droplet eliminator g = 2

Right-hand connection side

Left-hand connection side

Output variant	L ₂	H
2	500	250
3	500	250
4	500	250
6	600	170

Dimensions and weights

Air cooler for evaporative refrigerant LQNP with spilt coil

Output variant 2

Size	Output variant 2									Weight, kg	
	ø C	ø D	ø E	ø F	ø K	G	M		Volume, L	Cu/Al	Cu/Cu
60	22	41,3	22	34,9	22	36	f=1	f=2	35	330	455
62	22	41,3	22	34,9	22	36	904	871	44	410	575
64	28,6	54	22	41,3	22	43	904	871	64	490	690
71	22	41,3	22	34,9	22	36	1037	1004	50	470	665
73	–	–	22	41,3	22	43	–	1004	74	540	800
80	22	54	22	34,9	22	36	1204	1171	58	520	740

Output variant 3

Size	Output variant 3									Weight, kg	
	ø C	ø D	ø E	ø F	ø K	G	M		Volume, L	Cu/Al	Cu/Cu
60	26,6	54	22	34,9	22	36	f=1	f=2	60	370	440
62	28,6	54	22	34,9	22	36	904	871	73	460	545
64	28,6	54	22	34,9	22	36	904	871	86	550	645
71	28,6	54	22	41,3	22	43	1037	1004	70	530	625
73	28,6	54	22	41,3	22	43	1037	1004	98	630	740
80	28,6	54	22	41,3	22	43	1204	1171	82	590	695

Output variant 4

Size	Output variant 4									Weight, kg	
	ø C	ø D	ø E	ø F	ø K	G	M		Volume, L	Cu/Al	Cu/Cu
60	22	54	22	34,9	22	36	f=1	f=2	73	410	505
62	28,6	54	22	41,3	22	43	904	871	90	510	630
64	28,6	54	22	41,3	22	43	904	871	108	610	755
71	–	–	22	41,3	22	43	–	1004	104	590	730
73	–	–	22	41,3	22	43	–	1004	122	710	885
80	–	–	22	54	22	58	–	1171	120	660	820

Output variant 6

Size	Output variant 6									Weight, kg	
	ø C	ø D	ø E	ø F	ø K	G	M		Volume, L	Cu/Al	Cu/Cu
60	28,6	54	22	41,3	22	43	f=1	f=2	99	510	615
62	28,6	54	22	41,3	22	43	904	871	125	640	770
64	28,6	54	22	41,3	22	43	904	871	151	770	930
71	–	–	22	41,3	22	43	–	1004	142	750	905
73	–	–	22	41,3	22	43	–	1004	172	900	1085
80	–	–	22	54	22	58	–	1171	166	830	1000

Dimensions and weights

Air cooler for evaporative refrigerant LQNP

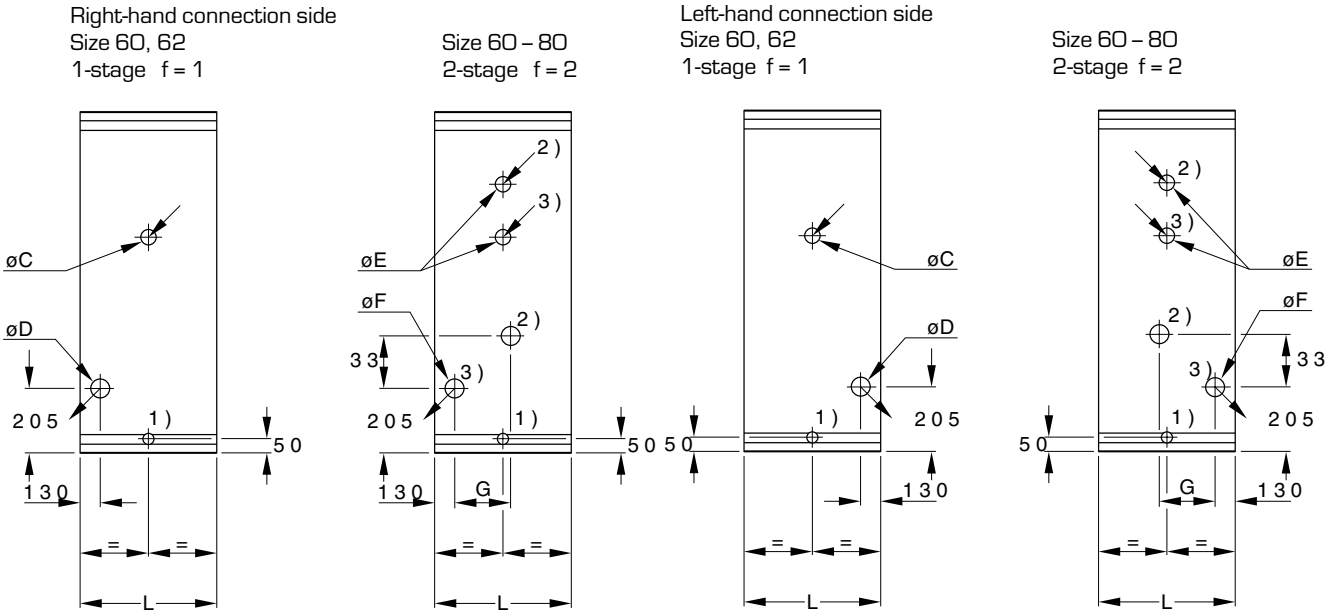

- 1) ø 32 mm o.d. drain plain, stainless steel pipe
- 2) Connection for stage 1/3
- 3) Connection for stage 2/3

For dimensions, see next page.

Normal face area c = 1, 3

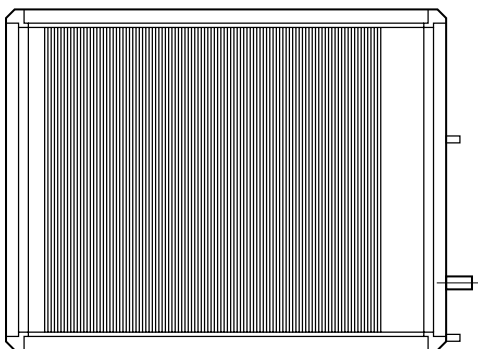

Normal face area c = 2, 4

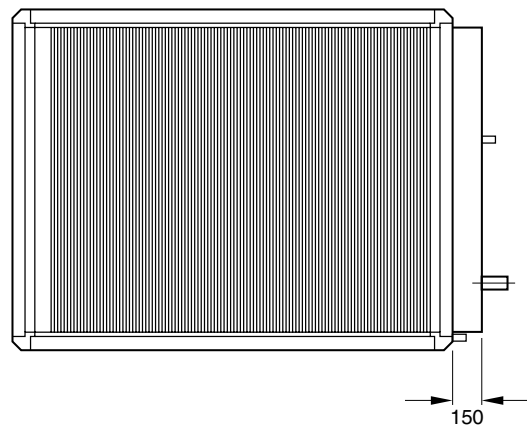

Dimensions and weights

Air cooler for evaporative refrigerant LQNP (cont.)

Output variant 2

Size	Output variant 2								Weight, kg	
	f=		ø C	ø D	ø E	ø F	G	Volume L	Cu/Al	Cu/Cu
	1	2								
60	•	•	28,6	54	22	41,3	43	35	330	455
62	•	•	28,6	54	22	41,3	43	44	410	575
64	–	•	–	–	28,6	54	58	64	490	690
71	–	•	–	–	22	41,3	43	50	470	665
80	–	•	–	–	22	54	58	58	520	740

Effektvariant	L
2 – 4	550
6	650

Output variant 3

Size	Output variant 3								Weight, kg	
	f=		ø C	ø D	ø E	ø F	G	Volume L	Cu/Al	Cu/Cu
	1	2								
60	–	•	–	–	28,6	54	58	60	370	440
62	–	•	–	–	28,6	54	58	73	460	545
64	–	•	–	–	28,6	54	58	86	550	645
71	–	•	–	–	28,6	54	58	70	530	625
73	–	•	–	–	28,6	54	58	98	630	740
80	–	•	–	–	28,6	54	58	82	590	695

Output variant 4

Size	Output variant 4								Weight, kg	
	f=		ø C	ø D	ø E	ø F	G	Volume L	Cu/Al	Cu/Cu
	1	2								
60	–	•	–	–	22	54	58	73	410	505
62	–	•	–	–	28,6	54	58	90	510	630
64	–	•	–	–	28,6	54	58	108	610	755

Output variant 6

Size	Output variant 4								Weight, kg	
	f=		ø C	ø D	ø E	ø F	G	Volume L	Cu/Al	Cu/Cu
	1	2								
60	–	•	–	–	28,6	54	58	99	510	615
62	–	•	–	–	28,6	54	58	125	640	770
64	–	•	–	–	28,6	54	58	151	770	930

Dimensions and weights

LQLR, motor outside, g = 5 – 8

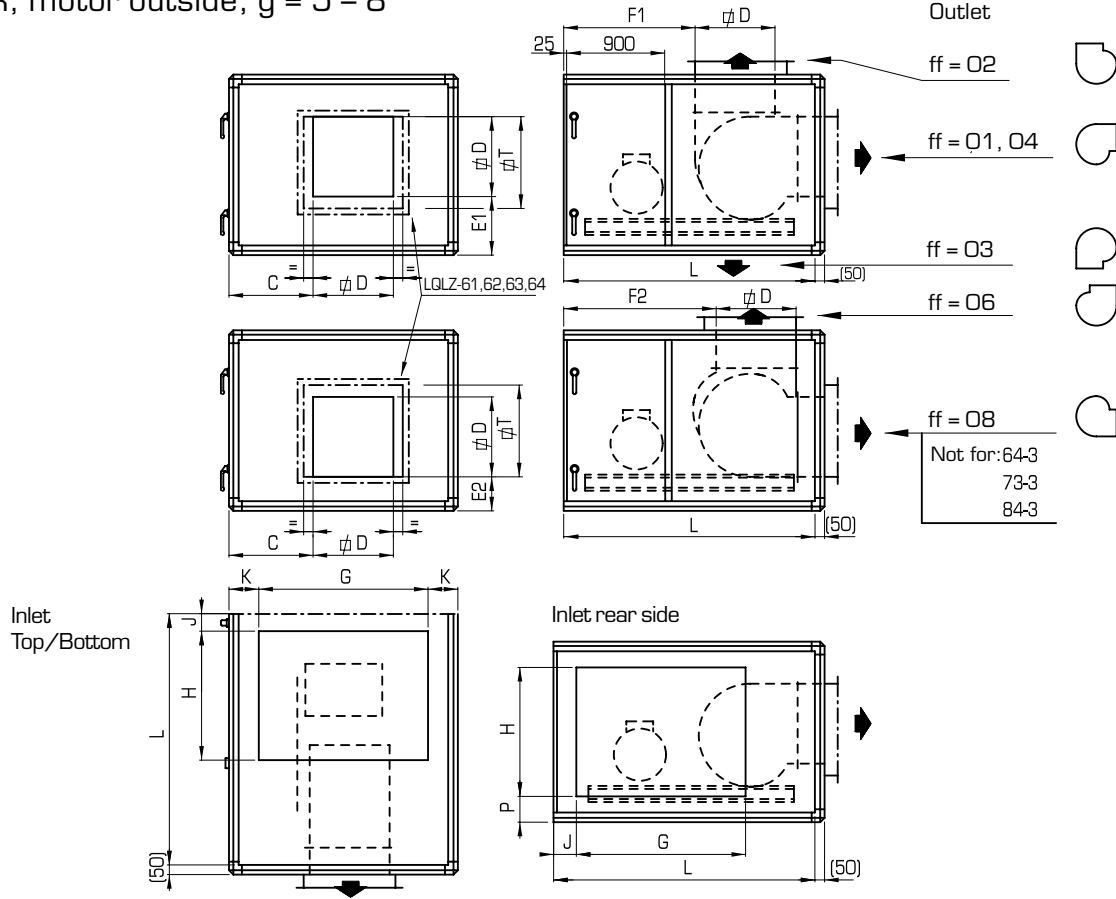

Size aa	b	C	D	E1	E2	F1	F2	ff=11 – 38		Forward		Up/down		P	U	T	Fan size GX		
								G	H	J	K	L	kg					L	kg
60	1	625	800	520	210	763	1122	1400	1400	100	325	1900	686	2000	686	325	100	1000	063
	2	575	900	570	210	905	1270	1400	1400	100	325	2050	806	2250	806	325	100	1000	071 _F
	3	525	1000	730	270	910	1370	1400	1400	100	325	2450	1049	2450	1049	325	100	1200	080
62	1	1200	900	655	296	446	823	1400	1400	100	625	1600	794	1800	794	225	100	1000	071 _S
	2	1145	1000	730	270	240 ¹	700	1600	1600	100	525	1800	952	1800	952	225	100	1200	080
	3	760	1130	790	310	1135	1639	1600	1600	100	525	2850	1315	2850	1315	225	100	1200	090
64	1	1445	1000	730	270	240 ¹	700	1600	1600	100	825	1800	1010	1800	1010	225	100	1200	080 _S
	2	1420	1130	790	270	309	813	1600	1600	100	825	1950	1135	2050	1135	225	100	1200	090 _{F/S}
	3	1380	1270	640	-	335	880	1600	1600	100	825	2250	1277	2250	1277	225	100	1400	100 _S
71	1	1145	1000	730	270	240 ¹	700	1600	1600	100	525	1800	992	1800	992	375	100	1200	080 _S
	2	760	1130	830	310	1175	1695	1800	1800	100	425	2900	1382	2900	1382	275	200	1200	090 _F
	3	690	1270	850	360	1185	1730	1800	1800	100	425	3100	1504	3100	1504	275	200	1400	100
73	1	1420	1130	830	310	300	820	1800	1800	75	725	1950	1181	2050	1181	275	125	1200	090 _S
	2	1380	1270	850	360	335	880	1800	1800	100	725	2150	1326	2250	1326	275	125	1400	100 _S
	3	1340	1250	950	-	370	1120	1800	1800	100	725	2500	1586	2500	1586	275	125	1400	112 _S
80	1	1145	1000	730	270	240 ¹	700	1800	1800	100	525	1800	1027	1800	1027	525	100	1200	080 _S
	2	760	1130	830	310	1175	1695	1600	1600	100	425	2900	1433	2900	1433	425	175	1200	090 _F
	3	690	1270	850	360	1185	1730	1800	1800	100	425	3100	1557	3100	1557	425	175	1400	100
82	1	1420	1130	830	310	300	820	1800	1800	75	725	1950	1227	2050	1227	425	125	1200	090 _S
	2	1380	1270	850	360	335	880	2000	2000	75	625	2150	1374	2250	1374	425	125	1400	100 _S
	3	1340	1250	1110	360	370	1120	2000	2000	100	625	2500	1638	2500	1638	325	125	1400	112 _S
84	①	1755	1270	850	360	335	880	2000	2000	75	1000	2150	1474	2250	1474	325	125	1400	100 _S
	②	1715	1250	1110	360	370	1120	2000	2000	100	1000	2500	1747	2500	1747	325	125	1400	112 _S
	③	1600	1400	1060	-	445	1300	2000	2000	100	1000	2900	2200	2900	2200	325	125	1600	125 _S

○ = To be ordered in a separate casing block
 F = + F-wheel, S = Motor placed beside fan. *) ff = f3 - F1 = 300

Dimensions and weights

LQLR, g = 2,4

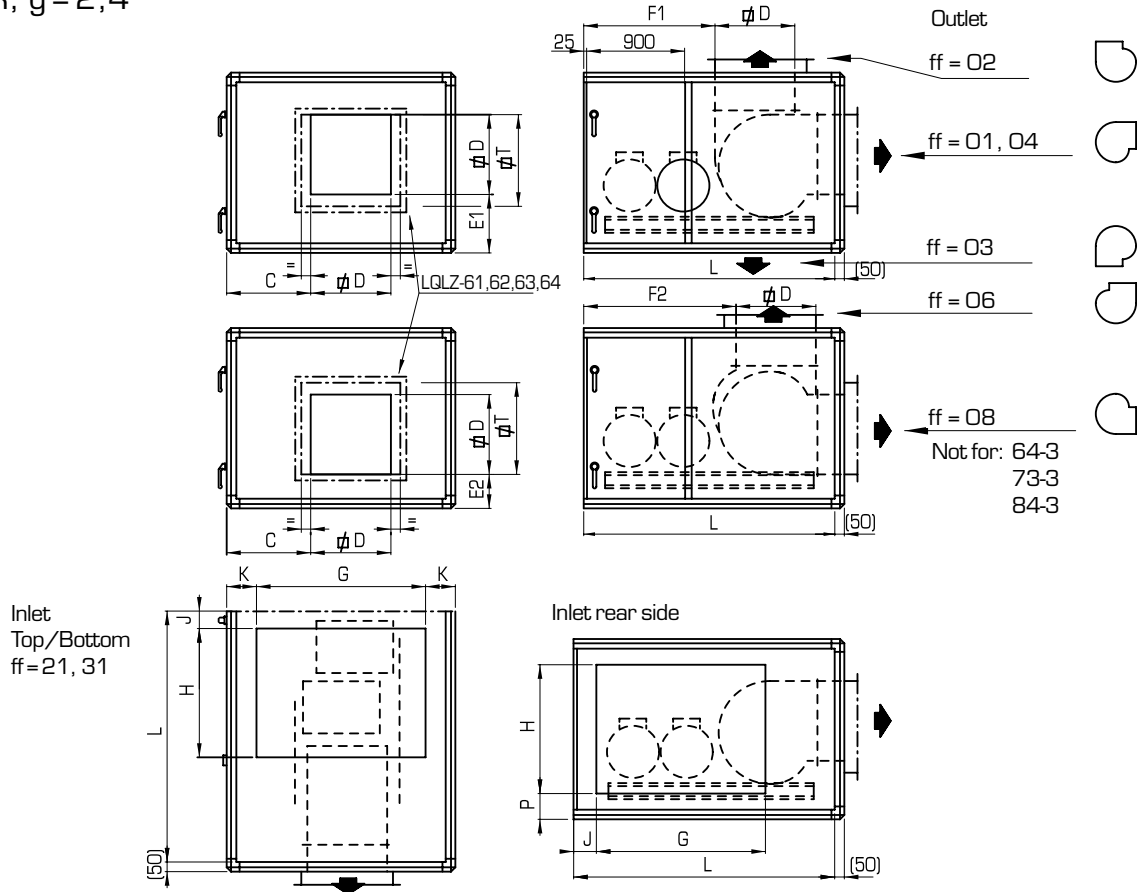

Size aa	ff=11 - 38										Fan size					
	b	C	D	E1	E2	G	H	U	K	L	P	F1	F2	T	Wgt, kg	GX
60	1	625	800	520	210	1400	1400	100	325	2600	325	1363	1722	1000	819	063
	2	575	900	570	210	1400	1400	100	325	3000	325	1655	2020	1000	969	071 _F
	3	525	1000	730	270	1400	1400	100	325	3200	325	1660	2120	1200	1211	080
62	1	1200	900	655	296	1400	1400	100	625	2300	325	946	1323	1000	927	071 _S
	2	1145	1000	730	270	1600	1600	100	525	2450	225	900	1360	1200	1118	080 _{F,SL}
	3	760	1130	790	310	1600	1600	100	525	3750	225	2025	2545	1200	1538	090
64	1	1445	1000	730	270	1600	1600	100	825	2450	225	900	1360	1200	1192	080 _{S,L}
	2	1420	1130	790	270	1600	1600	100	825	2850	225	1125	1645	1200	1355	090 _{F,SL}
	3	1380	1270	640	-	1600	1600	100	825	2450	225	335	880	1400	1347	100 _S
71	1	1145	1000	730	270	1600	1600	100	525	2450	375	900	1360	1200	1178	080 _{S,L}
	2	760	1130	830	310	1800	1800	100	425	3750	275	2025	2545	1200	1615	090 _F
	3	690	1270	850	360	1800	1800	100	425	4200	275	2285	2830	1400	1797	100
73	1	1420	1130	830	310	1800	1800	100	725	2900	275	1175	1695	1200	1435	090 _{S,L}
	2	1380	1270	850	360	1800	1800	100	725	2500	275	385	930	1400	1421	100 _S
	3	1340	1250	950	-	1800	1800	100	725	2700	275	370	1120	1400	1668	112 _S
80	1	1145	1000	730	270	1800	1800	100	525	2450	525	900	1360	1200	1222	080 _{S,L}
	2	760	1130	830	310	1600	1600	100	425	3750	425	2025	2545	1200	1678	090 _F
	3	690	1270	850	360	1800	1800	100	425	4200	425	2285	2830	1400	1866	100
82	1	1420	1130	830	310	1800	1800	100	725	2900	425	1175	1695	1200	1502	090 _{S,L}
	2	1380	1270	850	360	2000	2000	100	625	2500	325	385	930	1400	1483	100 _S
	3	1340	1250	1110	360	2000	2000	100	625	2700	325	370	1120	1400	1733	112 _S
84	①	1755	1270	850	360	2000	2000	100	1000	2500	325	385	930	1400	1592	100 _S
	②	1715	1250	1110	360	2000	2000	100	1000	2700	325	370	1120	1400	1848	112 _S
	③	1600	1400	1060	-	2000	2000	100	1000	2900	325	445	1300	1600	2239	125 _S

○ = To be ordered in a separate casing block
 F = + F-wheel, S = Motor placed beside fan. SL = Beside and along with mounted motors.

Dimensions and weights

Plenum fan LQLK

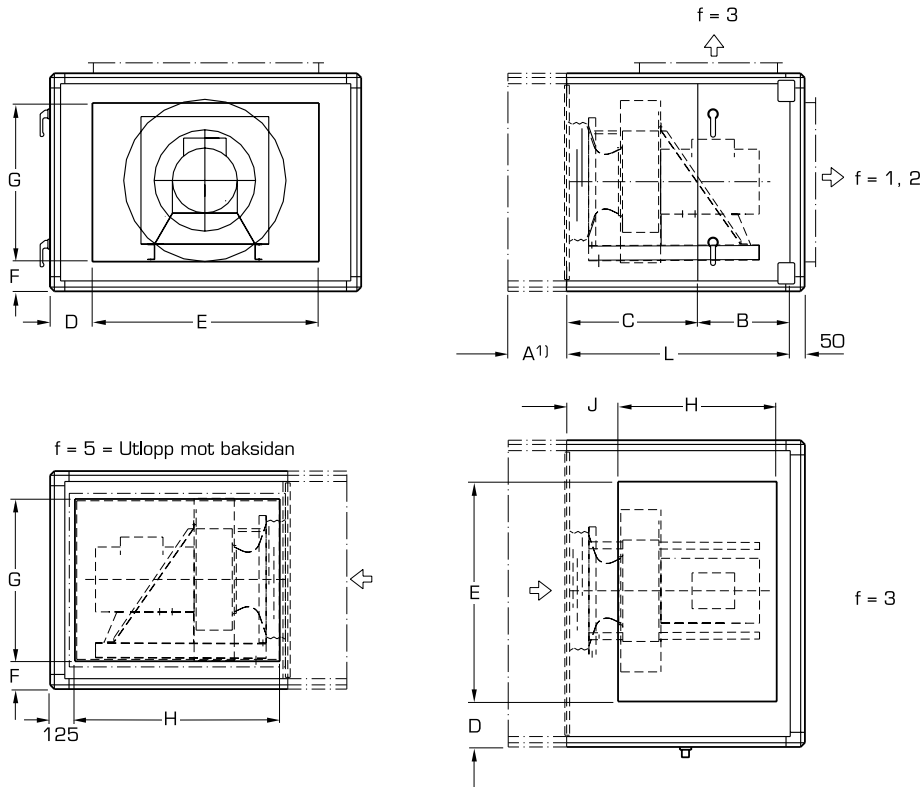

Size											
aa	b	A'1)	L	B	C	D	E	F	G	H	J
60	1	450	1450	700	750	225	1600	225	1600	1300	75
	2	450	1550	700	850	225	1600	225	1600	1400	75
	3	450	1650	700	950	225	1600	225	1600	1500	75
62	1	450	1450	700	750	525	1600	225	1600	1300	75
	2	450	1550	700	850	525	1600	225	1600	1400	75
	3	450	1350	700	650	525	1600	225	1600	1200	75
64	1	450	1650	700	950	825	1600	225	1600	1500	75
	2	450	1350	700	650	825	1600	225	1600	1200	75
	3	450	1450	700	750	825	1600	225	1600	1300	75
	4	450	1550	700	850	825	1800	125	1800	1400	75
71	1	450	1650	700	950	525	1600	375	1600	1500	75
	2	450	1350	700	650	425	1800	275	1800	1200	75
73	1	450	1650	700	950	725	1800	275	1800	1500	75
	2	450	1350	700	650	725	1800	275	1800	1200	75
	3	450	1450	700	750	725	1800	275	1800	1300	75
	4	450	1550	700	850	625	2000	175	2000	1400	75
80	1	450	1650	700	950	525	1600	525	1600	1500	75
	2	450	1350	700	650	425	1800	425	1800	1200	75
82	1	450	1350	700	650	725	1800	425	1800	1200	75
	2	450	1450	700	750	625	2000	325	2000	1300	75
	3	450	1550	700	850	625	2000	325	2000	1400	75
84	1	450	1450	700	750	1000	2000	325	2000	1300	75
	2	450	1550	700	850	1000	2000	325	2000	1400	75
	3	450	1650	700	950	1000	2000	325	2000	1500	75

Dimensions and weights

Evaporative humidifier LQQA

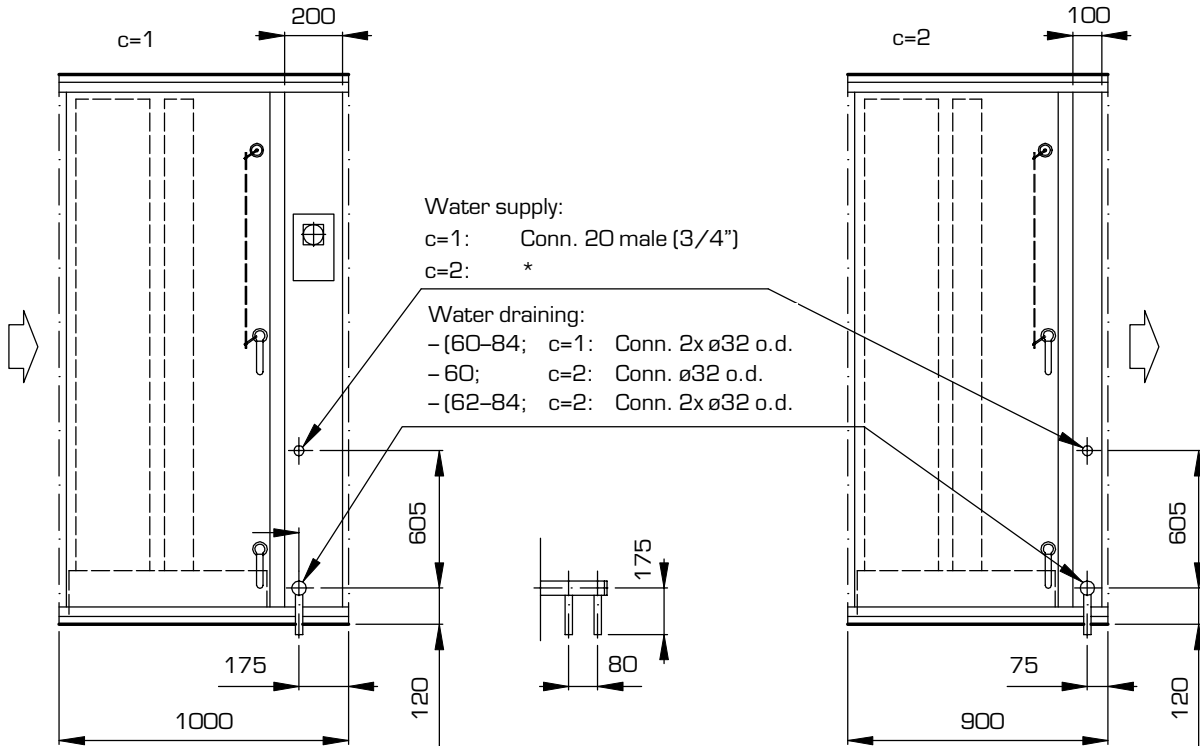

Size	c=1 Weight, kg	c=2 Weight, kg	Face area m ²
60	333	290	2,50
62	400	350	3,33
64	444	385	4,16
71	433	380	4,02
73	500	435	5,02
80	478	420	4,71
82	567	495	5,88
84	656	575	7,06

*) AA=60,62: Conn. 15 male (1/2")
 AA=64-82: B=4: Conn. 15 male (1/2")
 AA=84: Conn. 20 male (3/4")
 AA=64-82: B=3: Conn. 20 male (3/4")

Dimensions and weights

Silencer LQSA

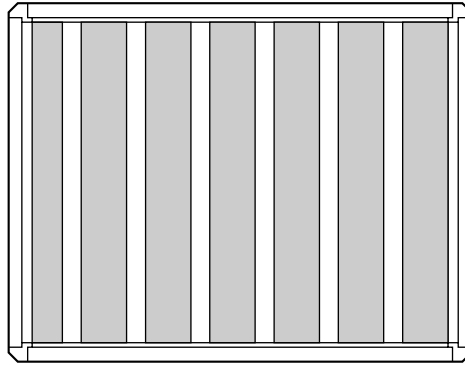
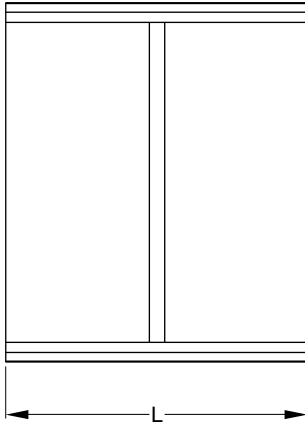

b = 2 - 5
 c = 6, 7
 d = 0
 g = 2

Size	Weight, kg for different lengths L =			
	550	900	1300	1700
60	230	360	500	640
62	286	447	618	790
64	339	528	729	931
71	314	487	672	931
73	372	576	792	1009
80	342	527	726	924
82	405	623	855	1087
84	474	728	997	1267

Dimensions and weights

Empty section LQTC

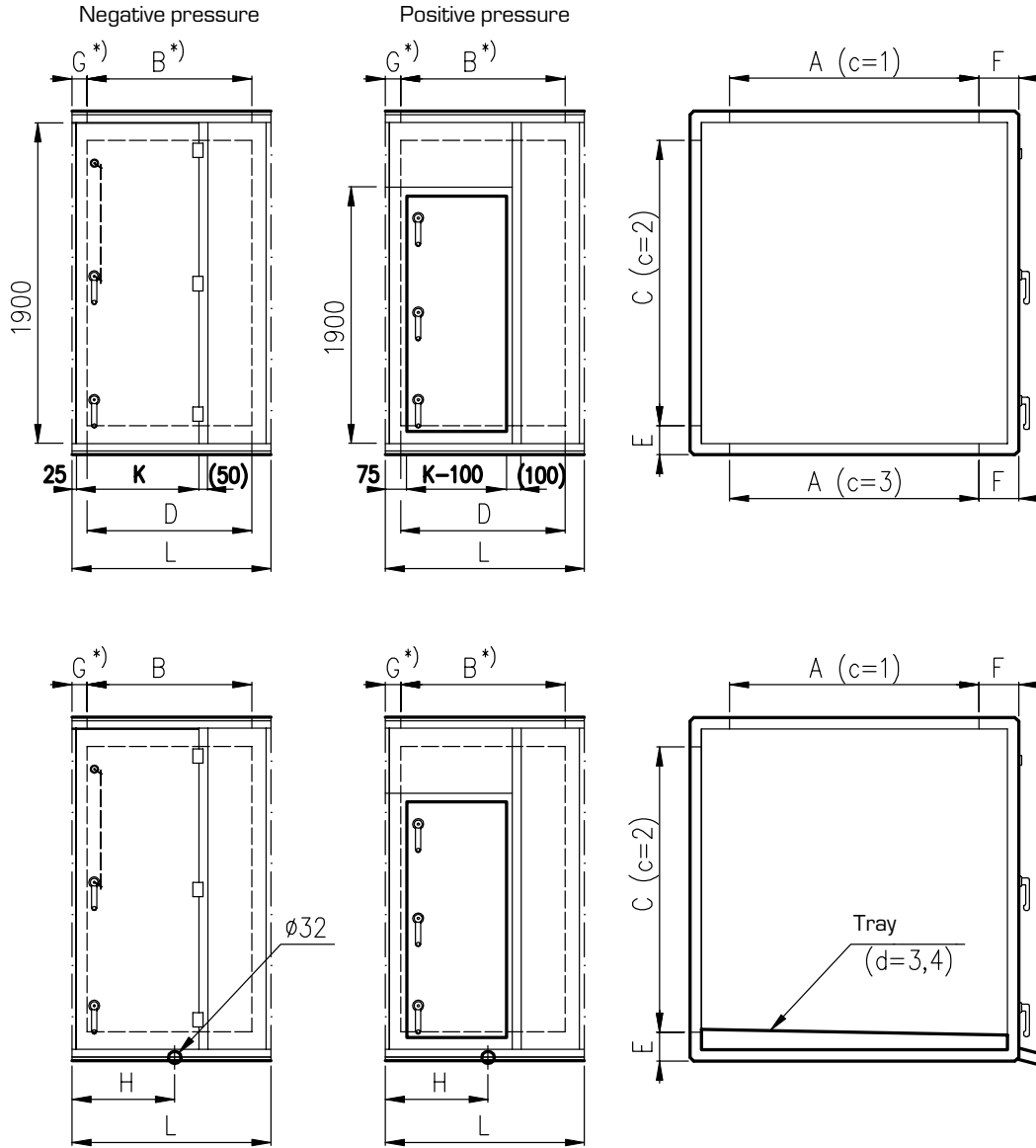

Size	A	C	E	F	C=1	C=2	C=3	C=4	C=5	C=6	C=7	C=8	C=9	L	B	D	G	H
					L=150	L=250	L=350	L=450	L=550	L=650	L=750	L=900	L=1000					
					Weight	Weight	Weight	Weight	Weight	Weight	Weight	Weight	Weight					
60	1600	1200	425	225	30	50	75	90	110	130	150	175	200	150	-	-	-	-
62	2000	1200	425	325	35	55	85	100	125	145	170	200	225	250	-	-	-	-
64	2800	1200	425	225	35	60	90	110	135	160	185	220	250	350	200	-	75	175
71	2000	1600	375	325	35	60	90	110	130	155	180	215	240	450	200	-	125	225
73	2800	1600	375	225	40	65	95	120	145	170	195	235	260	550	400	400	75	275
80	2000	1800	425	325	40	65	95	115	140	165	190	2350	255	650	400	400	125	325
82	2800	1800	425	225	40	110	100	125	150	180	205	250	275	750	600	600	75	375
84	3400	1800	425	300	45	115	115	140	170	200	230	280	310	900	600	600	150	450
-	-	-	-	-	-	K=200	K=300	K=400	K=500	K=600	K=700	K=600	K=600	1000	800	800	100	500

Dimensions and weights

Frost protection screen LQTE (support mesh for temperature sensors)

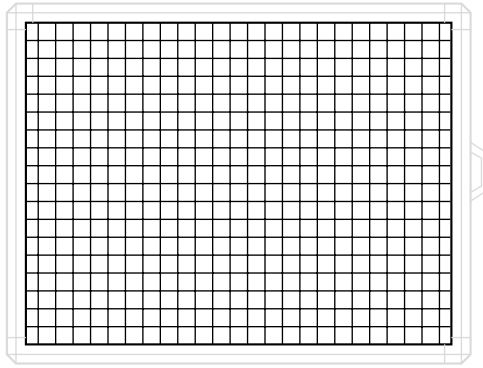
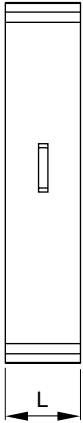

Size	Weight, kg
60	40
62	45
64	50
71	55
73	60
80	65
82	70
84	75

Dimensions and weights

Rotary heat exchanger LQRA – REGOTERM®

Size 60 – 84

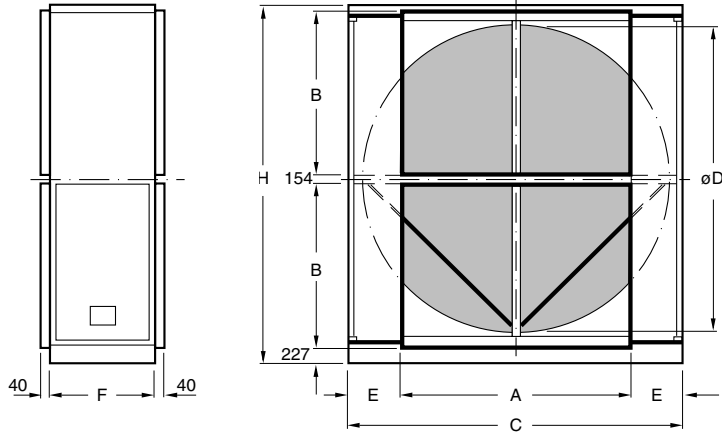

1) Internal frame dimension for connecting unit block

Assembling length (G) between unit block

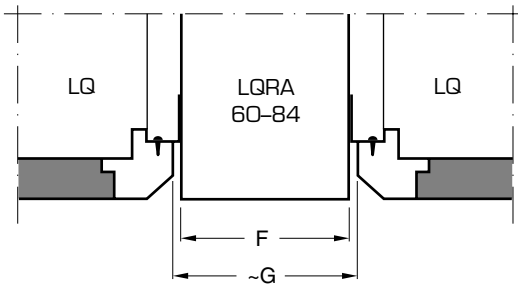

Size	A ¹⁾	B	C	ø D	E	F	G	H	Weight, kg			K
									b = 1,3 Normal	b = 2 Large	b=4,5 TURBOTERM	
60	1896	1896	3400	3200	752	434	450	4250	1350	1200	1425	–
62	2496	1896	3660	3460	582	434	450	4250	1450	1270	1540	–
64	3096	1896	4000	3800	452	434	450	4250	1700	1550	1810	–
71	2496	2196	4000	3800	752	434	450	4850	1700	1550	1810	–
73	3096	2196	4500	4200	702	434	450	4850	2025	1825	2160	–
80	2496	2496	4500	4200	1002	434	450	5450	2025	1825	2160	–
82	3096	2496	4500	4200	702	434	450	5450	2025	1825	2160	–
84	3846	2496	4900	4600	527	474	490	5450	2750	2550	2910	–

Sizes 60–84 with split casing to be assembled on site

Dimensions and weights

Liquid-coupled heat exchangers LQRF – ECOTERM®

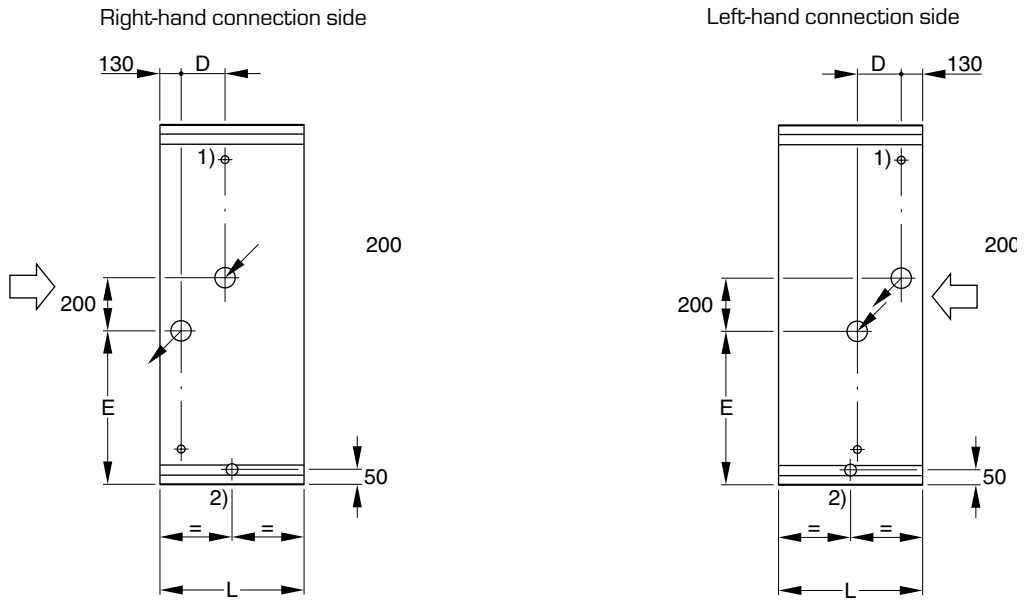

- 1) Conn.No. 8 (1/4" BSP) female pipe thread.
- 2) ø32 mm o.d. drain plain stainless steel pipe.

Normal face area

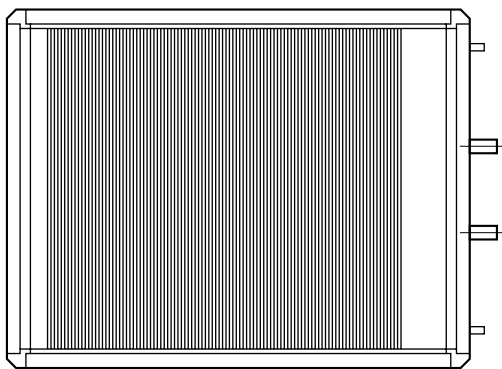

Max face area

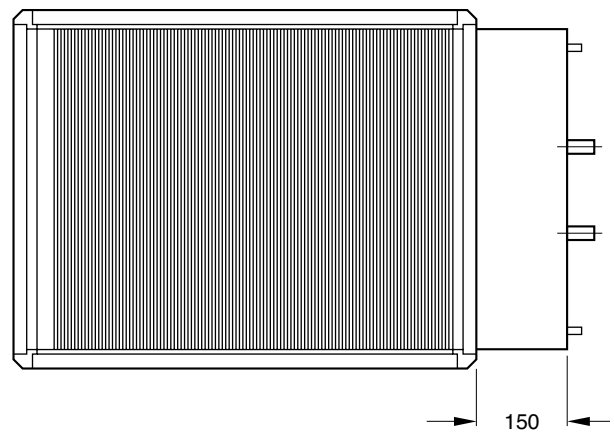

Dimensions and weights

Liquid-coupled heat exchangers LQRF – ECOTERM® (cont.)

Output variant 1

Size	Output variant 1				Weight, kg		
	D	b=1 E	b=2,3 E	Conn,	Volume L	g=1,4 Cu/Al	g=2,3 Cu/Cu
60	87	924	939	50	61	410	525
62	87	924	939	50	78	510	665
64	87	924	939	50	107	600	795
71	101	1074	1072	80	90	600	775
73	101	1074	1072	80	110	700	925
80	101	1224	1239	80	104	660	865
82	101	1224	1239	80	128	790	1050
84	101	1224	1239	80	156	950	1280

Output variant	b=1 L	b=2,3 L
1	550	550
2	550	650
3	550	650
4	550	750

Output variant 2

Size	Output variant 2				Weight, kg		
	D	b=1 E	b=2,3 E	Conn,	Volume L	g=1,4 Cu/Al	g=2,3 Cu/Cu
60	144	924	939	50	87	510	680
62	144	924	939	50	125	640	875
64	144	924	939	80	151	770	1065
71	144	1074	1072	80	130	750	1015
73	144	1074	1072	80	158	890	1225
80	144	1224	1239	80	150	830	1140
82	144	1224	1239	80	182	1000	1390
84	144	1224	1239	80	244	1200	1695

Output variant 3

Size	Output variant 3				Weight, kg		
	D	b=1 E	b=2,3 E	Conn,	Volume L	g=1,4 Cu/Al	g=2,3 Cu/Cu
60	205	924	939	50	113	580	810
62	205	924	939	50	159	730	1040
64	205	924	939	80	194	880	1270
71	205	1074	1072	80	168	860	1215
73	205	1074	1072	80	208	1030	1480
80	205	1224	1239	80	200	960	1375
82	205	1224	1239	80	260	1160	1685
84	205	1224	1239	80	315	1400	2060

Output variant 4

Size	Output variant 4				Weight, kg		
	D	b=1 E	b=2,3 E	Conn,	Volume L	g=1,4 Cu/Al	g=2,3 Cu/Cu
60	263	924	939	50	151	670	955
62	263	924	939	50	194	850	1240
64	263	924	939	80	237	1030	1520
71	263	1074	1072	80	208	1000	1445
73	263	1074	1072	80	272	1200	1760
80	263	1224	1239	80	242	1120	1640
82	263	1224	1239	80	316	1360	2015
84	263	1224	1239	80	400	1650	2475

Connections have male threads.
For details of flanges, see accessories.
Connection tolerance is ± 4 mm.

Dimensions and weights

Liquid coupled heat exchangers LQRF – ECOTERM® with split coil

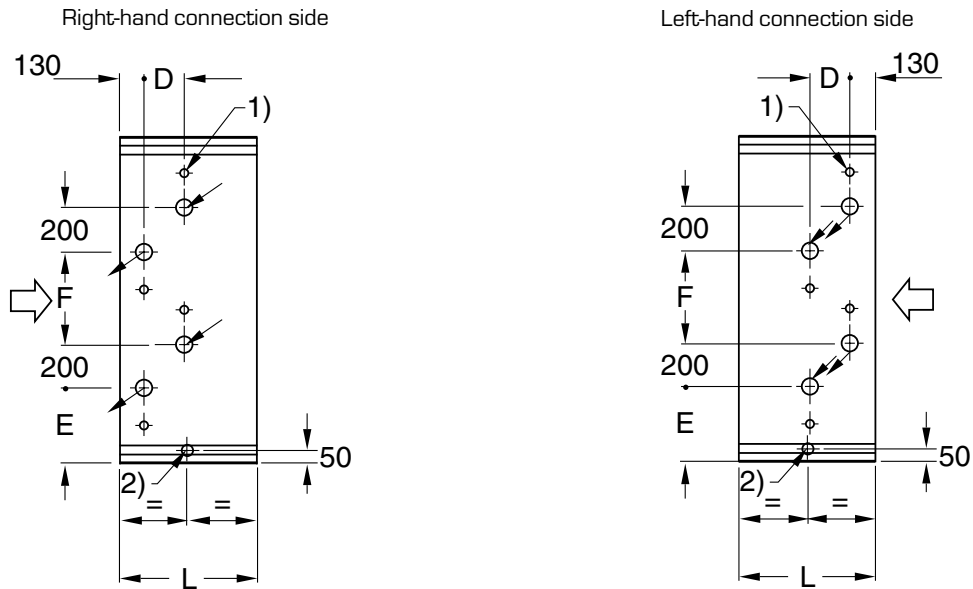

- 1) Conn. No. 8 (1/4" BSP) female pipe thread.
- 2) ø 32 mm o.d. drain plain stainless steel pipe.

Normal face area

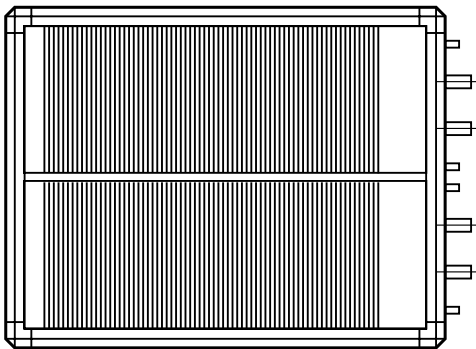

Max. face area

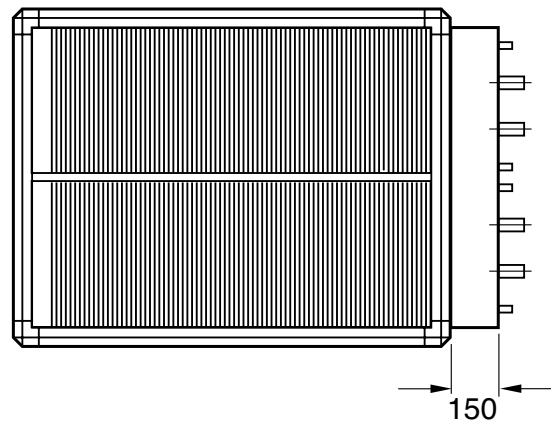

Dimensions and weights

Liquid coupled heat exchangers LQRF – ECOTERM® with split coil

Output variant 1

Size	Output variant 1					Weight, kg		
	D	b=1 E	b=2-4 E	F	Conn.	Volume L	g=1,4 Cu/Al	g=2,3 Cu/Cu
60	87	474	489	704	50	61	410	525
62	87	474	489	704	50	78	510	665
64	87	474	489	704	50	107	600	795
71	87	558	556	837	50	90	600	775
73	87	558	556	837	50	110	700	925
80	87	624	639	1004	50	104	660	865
82	87	624	639	1004	50	128	790	1050
84	87	624	639	1004	50	153	950	1280

Output variant	b=1 L	b=2,3 L
1	550	550
2	550	650
3	550	650
4	550	750

Output variant 2

Size	Output variant 2					Weight, kg		
	D	b=1 E	b=2-4 E	F	Conn.	Volume L	g=1,4 Cu/Al	g=2,3 Cu/Cu
60	144	474	489	704	50	61	510	680
62	144	474	489	704	50	78	640	875
64	144	474	489	704	50	107	770	1065
71	144	558	556	837	50	90	750	1015
73	144	558	556	837	50	110	890	1225
80	144	624	639	1004	50	104	830	1140
82	144	624	639	1004	50	128	1000	1390
84	144	624	639	1004	50	153	1200	1695

Output variant 3

Size	Output variant 3					Weight, kg		
	D	b=1 E	b=2-4 E	F	Conn.	Volume L	g=1,4 Cu/Al	g=2,3 Cu/Cu
60	205	474	489	704	50	113	580	810
62	205	474	489	704	50	159	730	1040
64	205	474	489	704	50	194	880	1270
71	205	558	556	837	50	168	860	1215
73	205	558	556	837	50	208	1030	1480
80	205	624	639	1004	50	200	960	1375
82	205	624	639	1004	50	260	1160	1685
84	205	624	639	1004	50	315	1400	2060

Output variant 4

Size	Output variant 4					Weight, kg		
	D	b=1 E	b=2-4 E	F	Conn.	Volume L	g=1,4 Cu/Al	g=2,3 Cu/Cu
60	263	474	489	704	50	151	670	955
62	263	474	489	704	50	194	850	1240
64	263	474	489	704	50	237	1030	1520
71	263	558	556	837	50	208	1000	1445
73	263	558	556	837	50	272	1200	1760
80	263	624	639	1004	50	242	1120	1640
82	263	624	639	1004	50	316	1360	2015
84	263	624	639	1004	50	400	1650	2475

Connections have male threads.
For details of flanges, see accessories.
Connection tolerance is ± 4 mm.

Dimensions and weights

Liquid-coupled heat exchanger LQRT – ECONET®

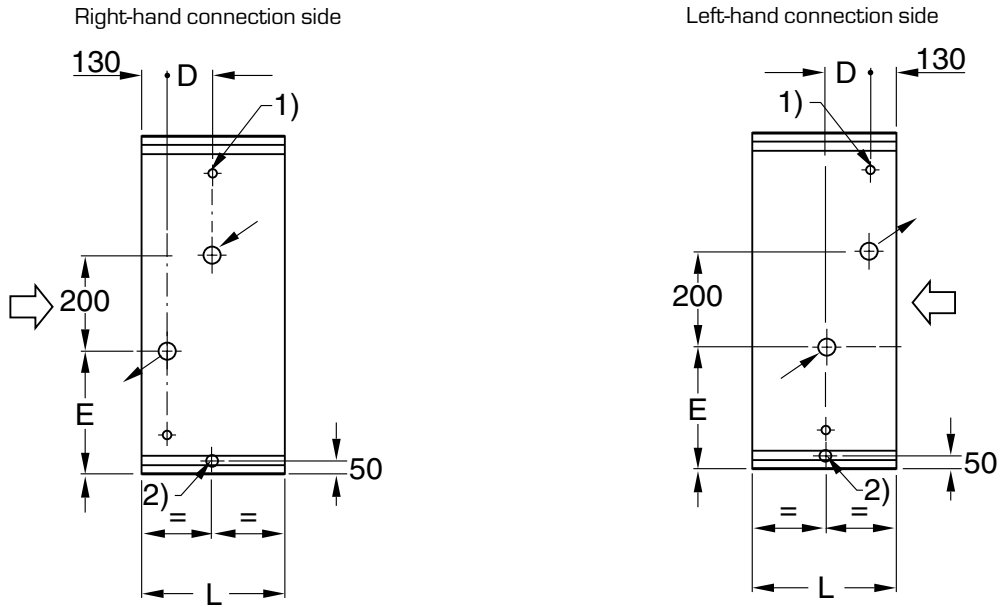

- 1) Conn. No. 8 (1/4" BSP) female pipe thread
- 2) ø 32 mm o.d. drain plain stainless steel pipe

Normal face area d=1,3

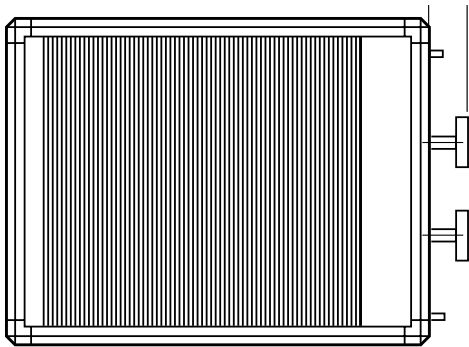

Max. face area d=2,5,7

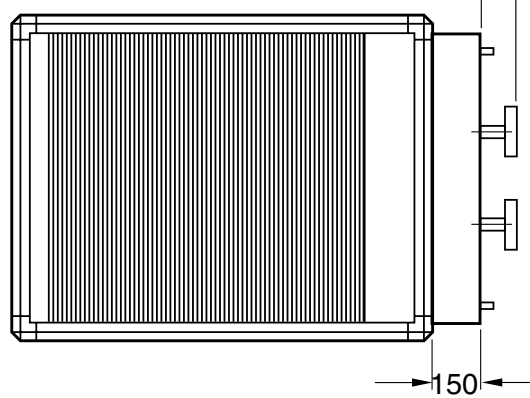

Output variant	L
2	650
3	650
4	750
5	850

Dimensions and weights

Liquid-coupled heat exchanger LQRT – ECONET®

Output variant 2

Output variant 2					
Size	D	E	Conn. ¹⁾	Volume L	Weight, kg
60	144	939	50	86	510
62	144	939	80	122	640
64	144	939	80	145	770
71	144	1072	80	139	750
73	144	1072	80	167	890
80	144	1239	80	162	830
82	144	1239	80	194	1000
84	144	1239	80	233	1200

Output variant 3

Output variant 3					
Size	D	E	Conn. ¹⁾	Volume L	Weight, kg
60	205	939	50	112	580
62	205	939	80	155	730
64	205	939	80	187	880
71	205	1072	80	178	860
73	205	1072	80	215	1030
80	205	1239	80	207	960
82	205	1239	80	249	1160
84	205	1239	80	302	1400

Output variant 4

Output variant 4					
Size	D	E	Conn. ¹⁾	Volume L	Weight, kg
60	263	939	50	149	670
62	263	939	80	189	850
64	263	939	80	229	1030
71	263	1072	80	217	1000
73	263	1072	80	263	1200
80	263	1239	80	252	1120
82	263	1239	80	305	1360
84	263	1239	80	371	1620

Output variant 5

Output variant 5					
Size	D	E	Conn. ¹⁾	Volume L	Weight, kg
60	321	939	50	175	790
62	321	939	80	223	985
64	321	939	80	271	1200
71	321	1072	80	243	1170
73	321	1072	80	311	1360
80	321	1239	80	282	1280
82	321	1239	80	361	1500
84	321	1239	80	440	1830

Connections have male threads.
For details of flanges, see accessories.
Connection tolerance is ± 4 mm.

Dimensions and weights

Accessories

LGAZ-25 ¹⁾
Flexible connection

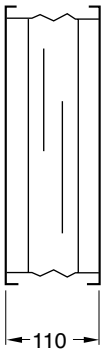

LGAZ-26
Duct connection

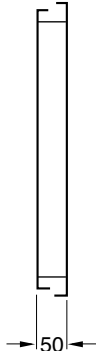

LGAZ-27 ¹⁾
Counter flange



LGAZ-28 ¹⁾
Damper

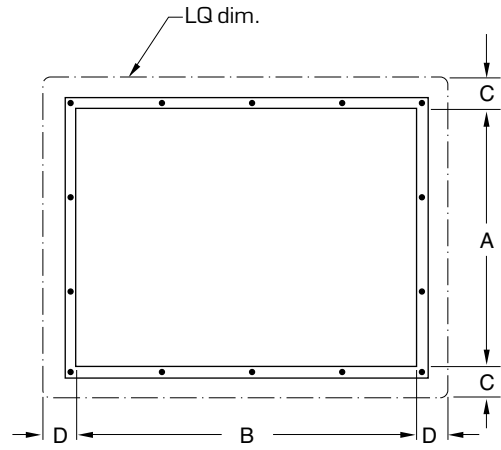
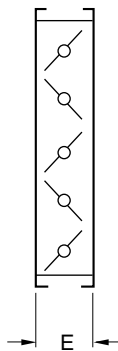

¹⁾ To be assembled on LGAZ-26

LGAZ-28
Size 44, 53, 62, 64

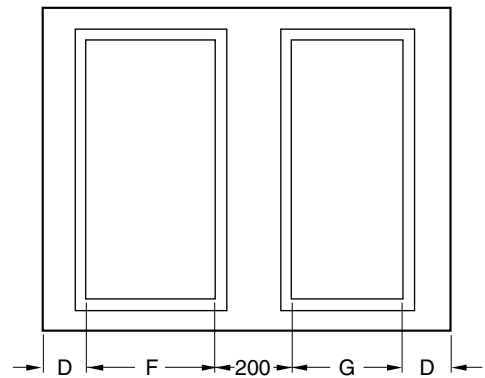

Size	A	B	C	D	E PG	E flange	F	G	Weight (kg) LGAZ-			
									-25	-26	-27	-28
60	1800	1800	125	125	240	215	-	-	12	14	10	73
62	1800	2400	125	125	240	215	1200	1000	14	16	12	106
64	1800	3000	125	125	240	215	1400	1400	16	18	14	126
71	2200	2400	75	125	-	-	-	-	16	14	13	-
73	2200	3000	75	125	-	-	-	-	18	16	15	-
80	2500	2400	75	125	-	-	-	-	17	14	14	-
82	2500	3000	75	125	-	-	-	-	19	17	16	-
84	2500	3800	75	100	-	-	-	-	21	17	18	-

Index

eQ Family.....	2	Heat Recovery	20
Introduction.....	3	ECOTERM	20
Air Handling with technology in the centre ...	4	ECONET.....	21
Fans at the heart of the system.....	5	Accessories	
Centrifugal fans.....	5	Lifting wires.....	22
Plug fans.....	5	Lifting spreaders	22
Many accessories to choose from	5	Lifting tubes.....	22
Highly efficient heat recovery		Inspection window	23
Regoterm.....	6	Base frame	23
Ecoterm	6	Water trap	23
Turboterm.....	6	Light fitting	23
ControlMaster - control when demands		Manometer.....	24
are high		Differential pressure gauge.....	24
Simple planning	7	Filter monitor	24
Quick installation.....	7	Connection accessories on the air side.....	25
A system solution.....	7	Dimensions – Quick Selection	26
A robust Casing platform		Quick selection tables	27
Security on every door.....	8	Control equipment.....	29
Environmentally safe insulation	8	Control Master.....	29
Design	9	Simple to engineer.....	29
Unit Description		Quick installation.....	29
Technical Data	10	Pre-delivery inspection	29
A unit that meets strict air handling demands.....	11	High quality	29
Design features	11	Simplicity	29
Framework.....	11	Description, General	30
Double-skin construction of casing panels	11	Description, Electrical Design.....	30
Doors	12	Fan Charts eQL	
Thermal insulation of the unit	12	Description.....	31
Insulation of the casing	12	LQLR-60-1.....	32
Casing tightness	13	LQLR-60-2/62-1.....	33
Environmental class.....	13	LQLR-60-3/62-2/64-1/71-1/80-1.....	34
Casing strength.....	13	LQLR-62-3/64-2/71-2/73-1/80-2/82-1.....	35
Definition	13	LQLR-64-3/71-3/73-2/80-3/82-2/84-1	36
Official test	13	LQLR-73-3/82-3/84-2.....	37
Sound attenuation in the unit casing.....	13	LQLR-84-3.....	38
Outdoor version.....	14	Plenum fan - Description.....	39
Hygiene version	14	LQLK-55-1/60-1/62-1	40
Dampers.....	15	LQLK-55-2/60-2/62-2	41
Filter 16		LQLK-55-8/62-3/64-2/66-2/71-2/73-2/ 75-1/80-2/82-1	42
Air heaters / Air coolers	17	LQLK-60-3/64-1/66-1/71-1/73-1/80-1.....	43
Humidifiers / Centrifugal fans / Plug fans	18		
Angle Section / Empty Section / Silencer	19		

Index

LQLK-64-3/66-3/73-3/75-2/ 82-2/84-1	44	Dimensions and weights	
LQLK-64-4/66-4/73-4/75-3/ 82-3/84-2	45	Unit casing	56
LQLK-75-4/84-3	46	Stacked units	57
Descriptive Texts		Inspection door	57
Introduction	47	Jointing frame between modules of different LQVH	58
Unit Design	47	Base frame LQAZ-04	59
Outdoor version	48	Roof LQBZ-01	60
Inspection	48	End connection frame LQVA	61
Duct Connections	49	Intake air section LQVB	62
Dampers	49	Mixing section LQVC	63
Mixing Section	49	Mixing section LQVD	65
Filter Sections	50	Mixing section LQVE (Outdoor unit)	68
Panel filters	50	Mixing section LQVF (Outdoor unit)	69
Bag filter, medium long	50	Mixing section LQVG (Outdoor unit)	70
Bag filters, long	50	Filter section LQP(A, C)	71
Absolute filters	50	Absolute filter LQPF	72
Carbon filters	50	Carbon filter LQPK	73
Air heaters, for hot water	51	Air heater for hot water LQEE	74
Electric air heaters	51	Air heater for hot water LQEV	74
Air coolers, for chilled water	51	Frost coil LQEG	75
Air coolers, direct expansion (dx)	52	Air heater, electric LQEK	76
Air cooler (incl. compressors, evaporators and condensers)	52	Air heater for steam LQES	78
Humidifier, evaporative	52	Air cooler for chilled water LQNN	79
Humidifier, steam	52	Air cooler for evaporative refrigerant LQNP	82
Rotary heat exchanger, REGOTERM	53	LQLR	86
Plate heat exchanger, RECUTERM	53	Plenum fan LQLK	88
Liquid-coupled heat exchangers, ECOTERM	53	Evaporative humidifier LQQA	89
Liquid-coupled heat exchangers, external energy, ECONET	53	Silencer LQSA	90
Belt-driven centrifugal fans	54	Empty section LQTC	91
Direct-driven plenum fans	55	Frost protection screen LQTE	92
Silencers	55	Rotary heat exchanger LQRA REGOTERM	93
Base frame	55	LQRF - ECOTERM	94
Accessories	55	Liquid-coupled heat exchanger LQRT - ECONET	98
		Accessories	100
		Index	101

Notes

A series of horizontal dotted lines for writing notes.

We Bring Air to Life

Fläkt Woods is a global leader in air management. We specialize in the design and manufacture of a wide range of air climate and air movement solutions.

Our collective experience is unrivalled. We are constantly aiming to provide systems that precisely deliver required function and performance as well as maximum energy efficiency.

Solutions for all your air climate and air movement needs

Fläkt Woods is providing solutions for ventilation and air climate for buildings as well as fan solutions for Industry and Infrastructure.

● Air Handling Units (AHUs)

Modular, compact and small AHU units. Designed to ensure optimisation of indoor air quality, operational performance and service life.

● Air Terminal Devices and Ducts

Supply and exhaust diffusers and valve for wall installation, ceiling or floor are all included in our large range and fit all types of applications.

● Chilled Beams

Available for suspended or flush mounted ceiling installation, a multiservice configuration is also available. You can take advantage of our Unique Comfort control and Flow pattern Control devices which can be used across the range of Beams.

● Residential ventilation

A complete range of products for residential ventilation. Consists of ventilation units, exhaust air fans and cooker hoods designed to optimise indoor comfort and save energy.

● Energy recovery

Our Dessicant based products and systems offer energy recovery, increase ventilation and control.

● Fans

Advanced axial, centrifugal and boxed fans for general and specialist applications. Comprehensive range including high temperature and ATEX compliant options. Engineered for energy efficiency and minimised life cycle cost.

● Chillers

Air-cooled and water-cooled chillers with cooling capacity up to 1800kW. Designed to minimised annual energy consumption in all types of buildings.

● Controls and drives

Variable speed drives and control systems, all tested to ensure total integration with our products. Specialist team can advise on energy saving and overall system integration.

● A complete range of Sounds

A complete range of sound attenuating products, including rectangular and round silencers. Media Free silencers, custom silencers and acoustic enclosure panels.

Fläkt Woods Group SA

18, avenue Louis Casai, CH-1209 Geneva, Switzerland
Tel. +41 22 309 3800
email info@flaktwoods.com www.flaktwoods.com

See global website for international sales offices www.flaktwoods.com

