

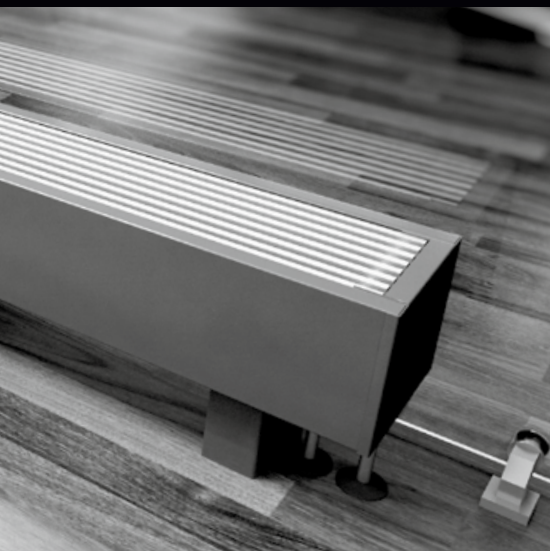

KORADO®

Convectors



LICON® 

member of KORADO Group

CONTENT



Introduction	4
Products overview	6

Natural convection convectors

Floor convectors KORAFLEX FK	8
• Convectors KORAFLEX FK building installation	14
• Floor convectors' design finishes	16
KORAFLEX PM cover grids and decorative frames	18
Free standing convectors KORALINE LK	24
Bench convectors with desk KORALINE LD	30
Wall mounted convectors KORAWALL WK	34
Facade convectors KORASPACE	38
Heat exchangers KORABASE	42

Systems OC

Convectors with forced and optimized convection

Floor convectors	48
• KORAFLEX FV (heating)	49
• KORAFLEX FV InPool (heating)	58
• KORAFLEX FI (heating or cooling)	61
• KORAFLEX FW (heating and cooling)	65
Free standing convectors KORALINE LV	72
Wall mounted convectors KORAWALL WI	78
• Mounting of convectors KORAWALL WI	81
OC Systems regulation and acoustics	82
• Elements of electrical regulation	84
• Wiring diagram (electrical circuits)	86
• Acoustics	90
Pressure losses	92
General information	94



Operating principle of floor convectors – KORAFLEX

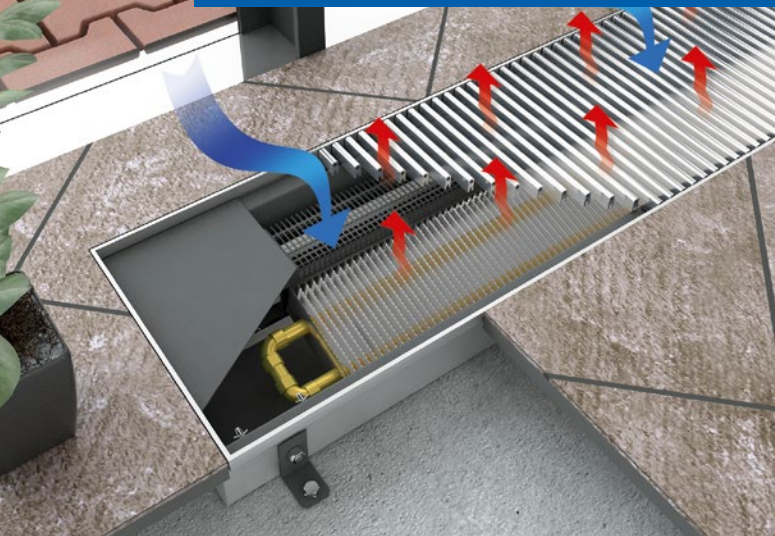

Operating principle of wall mounted convectors – KORAWALL

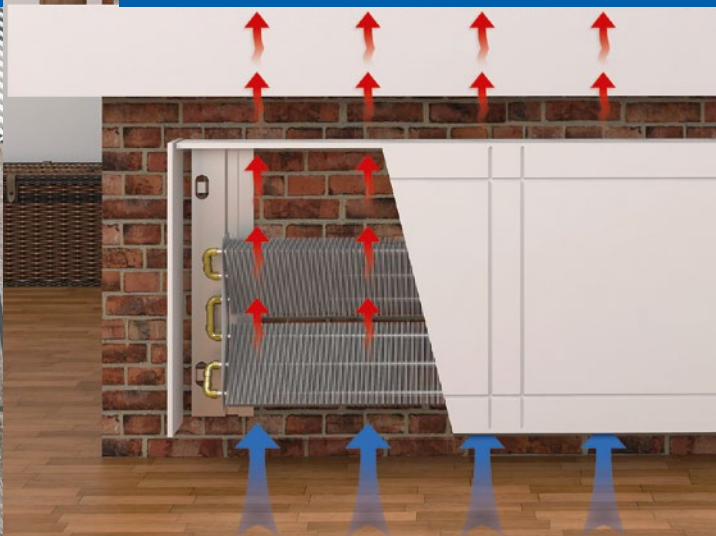

Optimized convection Convectors with forced convection

Entire production series  is optimised in terms of the noise level, heat output and power consumption required to operate the fans. Innovative and unique technology not only for heating but now also for cooling.



- significant energy savings
- very silent operation
- instant optimal heat outputs, higher efficiency
- variable regulation for all building types
- easier assembly, disassembly and maintenance
- universal use
- convector with higher efficiency, new heat exchangers



Image is for illustration only.

Natural convection

Heat transfer to a room takes place in heat exchanger, which consists of a copper pipe fitted with aluminium lamellas mechanically connected to the pipe. Flow of hot water through heat exchanger heats pipe and fins, heat from which is passed to surrounding rising air, performing chimney effect or convective flow of warm air in heating element.

- unique horizontal corrugation of the lamellas' surfaces
- better heat transfer to the room

Solutions for heat pumps

- convector series OC
- convectors can operate at low temperature gradients
- our convectors can effectively heat or cool
- cooling in summer, heating in winter

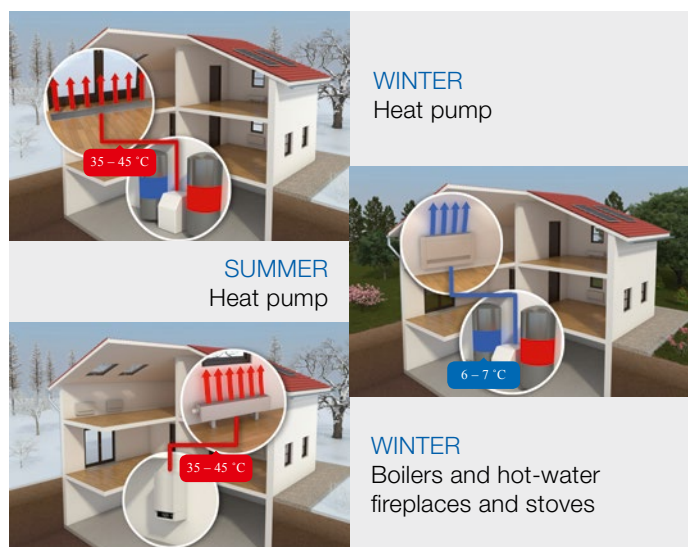



9 reasons to choose our convectors

- 1 innovative technical and design solutions
- 2 high efficiency, excellent solution for heat pumps
- 3 convectors provide heating and cooling
- 4 new pool design (marked with InPool)
- 5 low-cost operation, low power consumption, environment protection
- 6 wide range for each building, interior and heating type
- 7 fast heat distribution – efficiency, ecology, energy saving
- 8 solutions for interior, dry, damp and wet environments
- 9 suitable for all energy sources (heat pumps, gas, electricity, solar energy, wood and biomass)

Graphic symbols explanation

Convenient application



Functions and features

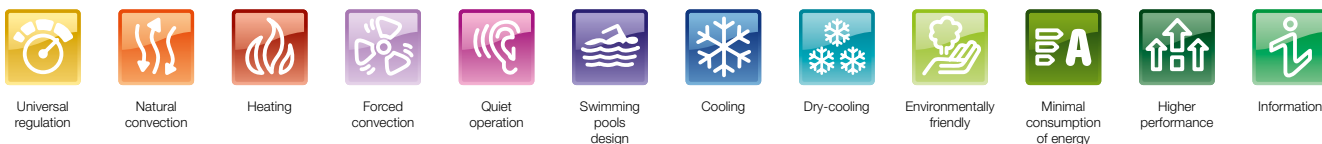

Design

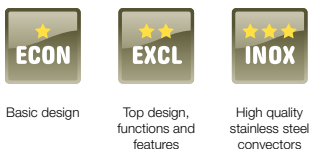

Technical parameters

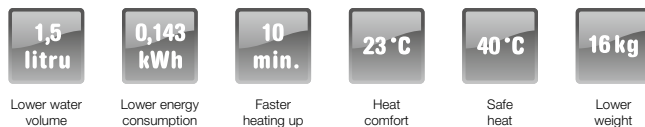

KORAFLEX FV 8/16 see page 49

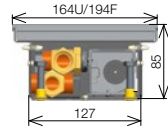

KORAFLEX FV 8/28 see page 50

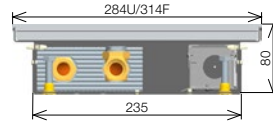

KORAFLEX FV 9/28 see page 51

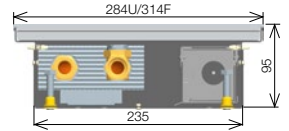

KORAFLEX FV 11/20 see page 52

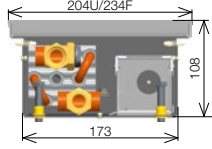

KORAFLEX FV 11/28 see page 53

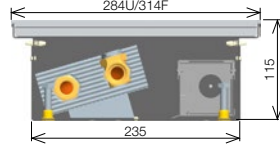

KORAFLEX FV 11/34 see page 54

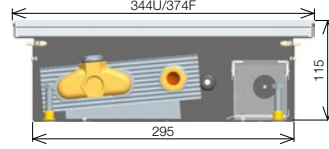

KORAFLEX FV 11/42 see page 55

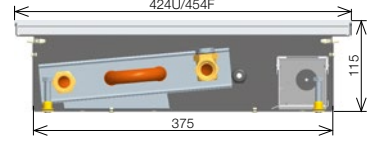

KORAFLEX FV InPool 11/34 see page 58

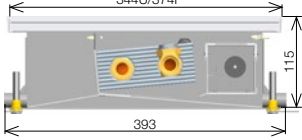

KORAFLEX FI 11/20 see page 61

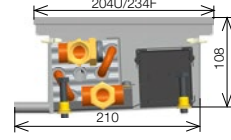

KORAFLEX FI 13/34 see page 62



KORAFLEX FW 13/34 see page 65

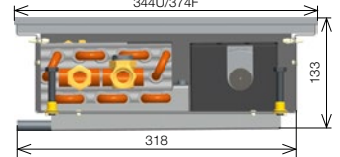

KORAFLEX FK 9/16 cm

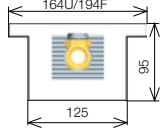

KORAFLEX FK 9/20 cm

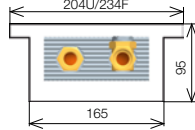

KORAFLEX FK 9/28 cm

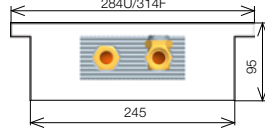

KORAFLEX FK 9/34 cm

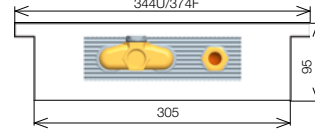

KORAFLEX FK 9/42 cm

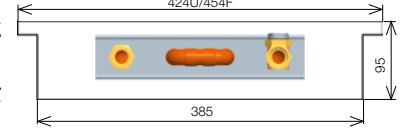

KORAFLEX FK 11/16 cm

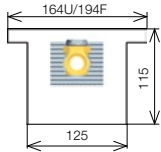

KORAFLEX FK 11/20 cm

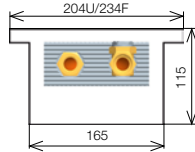

KORAFLEX FK 11/28 cm

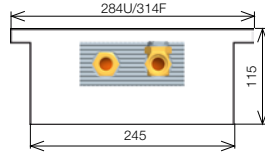

KORAFLEX FK 11/34 cm

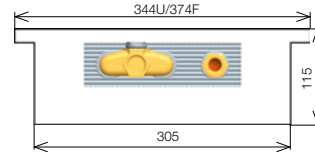

KORAFLEX FK 11/42 cm

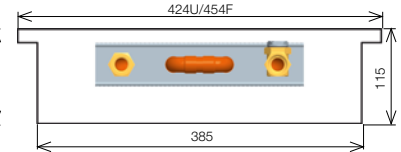

KORAFLEX FK 15/28 cm

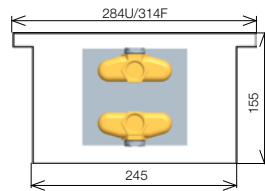

KORAFLEX FK 15/34 cm

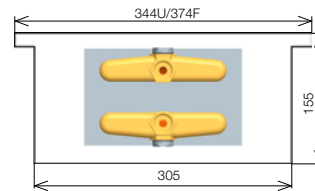

KORAFLEX FK 15/42 cm

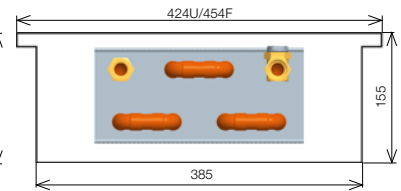

KORAFLEX FK 19/28 cm

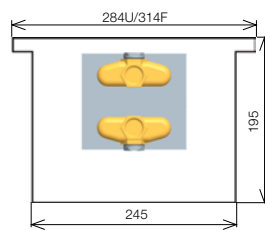

KORAFLEX FK 19/34 cm

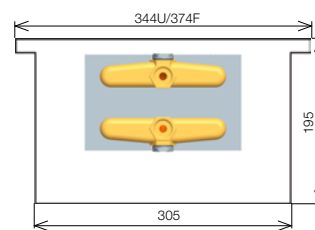

KORAFLEX FK 19/42 cm

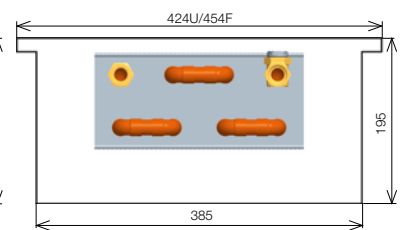

KORAFLEX FK 30/28 cm

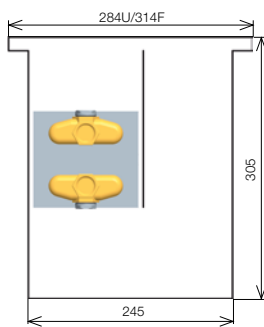

KORAFLEX FK 30/42 cm

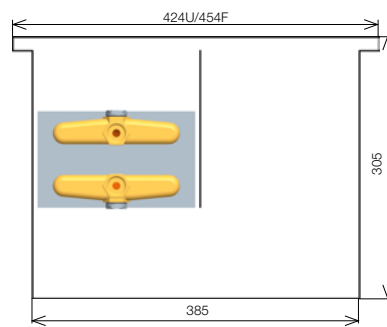

KORAFLEX FK 45/28 cm

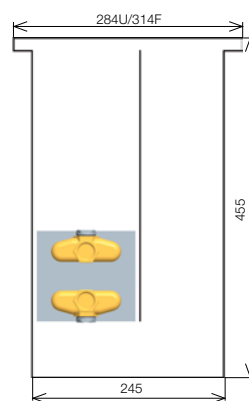

KORAFLEX FK 45/42 cm

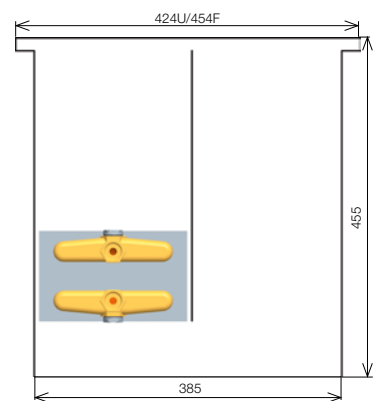

(see pages 8-17)

KORALINE LV
15/11 see page 73

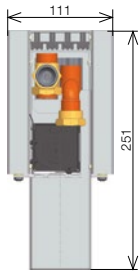

KORALINE LV
15/18 see page 74

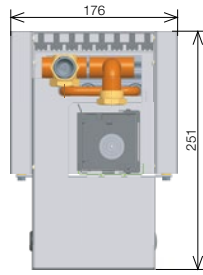

KORALINE LV
15/24 see page 75

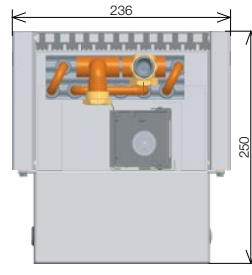

KORAWALL WI
45/11

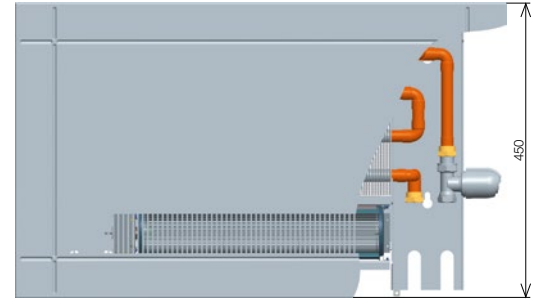

(see pages 79–81)

KORALINE LK
Width 18 cm
Height 9 cm

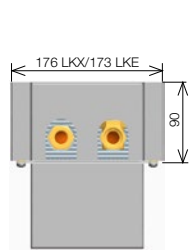

(see pages 24–29)

KORALINE LK
Width 18 cm
Height 15, 30, 45 and 60 cm

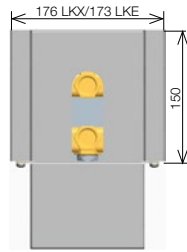

KORALINE LK
Width 24 cm
Height 9 cm

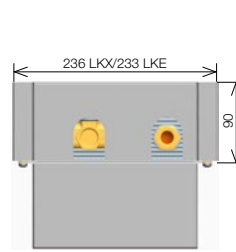

KORALINE LK
Width 24 cm
Height 15, 30, 45 and 60 cm

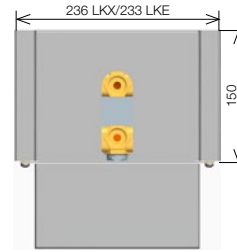

KORALINE LD

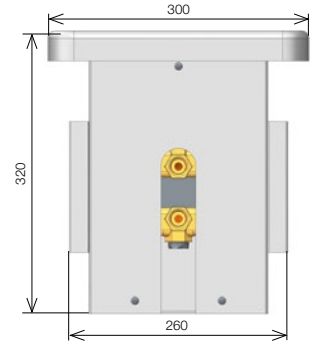

(see pages 30–33)

KORAWALL WK
Bottom connection
Depth 6 cm and 12 cm



(see pages 34–37)

Side connection
Depth 6 cm

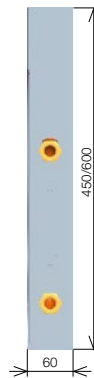

Side connection
Depth 12 cm

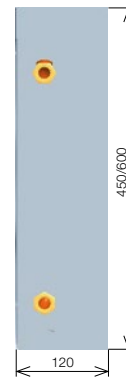

Bottom connection
Depth 6 cm

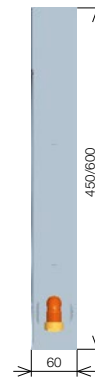

Bottom connection
Depth 12 cm

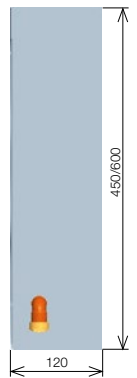

KORABASE

Type 10



Type 20

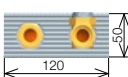

Type 30

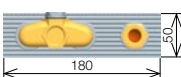

Type 22

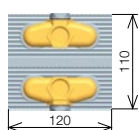

Type 32

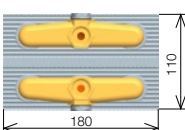

(see pages 42–45)

KORASPACE
Height 5.6 cm
Width 11.4 cm

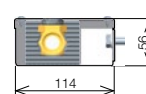

KORASPACE
Height 5.6 cm
Width 15 cm

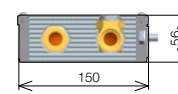

KORASPACE
Height 5.6 cm
Width 17.4 cm

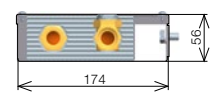

(see pages 38–41)



[KORAFLEX

FLOOR CONVECTORS (natural convection)

French windows will stand out, winter garden entries or balconies will completely open up. Heating units are not occupying interior doorways space. Unobtrusive, effective and aesthetically designed heating system for residential houses, shops and administrative buildings. Excellent use of floors for heating, visually inconspicuous.



Floor convectors with natural convection KORAFLEX FK • FK InPool

KORAFLEX FK convectors are intended for embedding in floors, especially in places prohibiting installation of higher radiators, e.g. in front of french windows, winter garden entries, hall entrances, exits etc., in public buildings (shops, administrative buildings etc.), as well as in residential houses. Various colored designs of the floor grids are making convectors suitable for each interior.

- Natural convection convectors
- Wide type & design range
- Easy to clean and maintain
- The floor convectors are intended for dry environment, for humid environment use version FK InPool

Standard delivery contains

- version **Economic** – black coated zinc galvanised steel case
- unpainted heat exchanger with low water content, air vent and uniquely shaped lamellas for higher heat output
- anodized Al frame, U profile, in colour of natural aluminium
- fixing anchors to fix the case to the floor
- a set of flexible stainless steel hoses for easy connection
- chipboard cover, protecting the exchanger against dust and dirt on the building site
- 25 mm height adjustment screws to compensate for the floor asperity
- mounting instructions
- the set is packed in a strong and durable packaging

Specifications

depth (mm)	90, 110, 150, 190, 300, 450
width (mm)	160, 200, 280, 340, 420
length (mm)	800 up to 3 000 (at 200 mm steps)
heat output (W)	from 87 to 4 100
max. working pressure (bar)	12
max. working temperature	110 °C
connecting thread	inner G 1/2"

Version Economic • basic version in black coated galvanized steel case, exchanger without surface finishes

Version Exclusive • black coated galvanized steel case, black coated exchanger
Version Inox • case made of stainless steel AISI 304, unpainted exchanger (only for dry environment)

Version InPool • case made of stainless steel AISI 316, unpainted exchanger (for humid environment)



Optional specification

- **Exclusive** – black coated zinc galvanised steel (identical with the design type Economic), black coated heat exchanger
- **InPool** – the case design in stainless steel AISI 316, unpainted exchanger (only for humid environment)
- **Inox** – the case design in stainless steel AISI 304, unpainted exchanger (only for dry environment)
- pool design FK InPool are standard designed with a drain hole
- colour of the anodized Al frame – natural aluminium, light and dark bronze in the F profile or light or dark bronze for U profile, see sketch page 23
- closeable screwing, thermostatic valve and thermostatic head with capillary
- cover plate with increased rigidity
- Insufficient performance? Look for version with OC with forced convection, see page 48

Floor grids page 18.



Note: Pool design available only for depths 9 and 11 and widths 20, 28, 34 and 42 cm.

Cross section

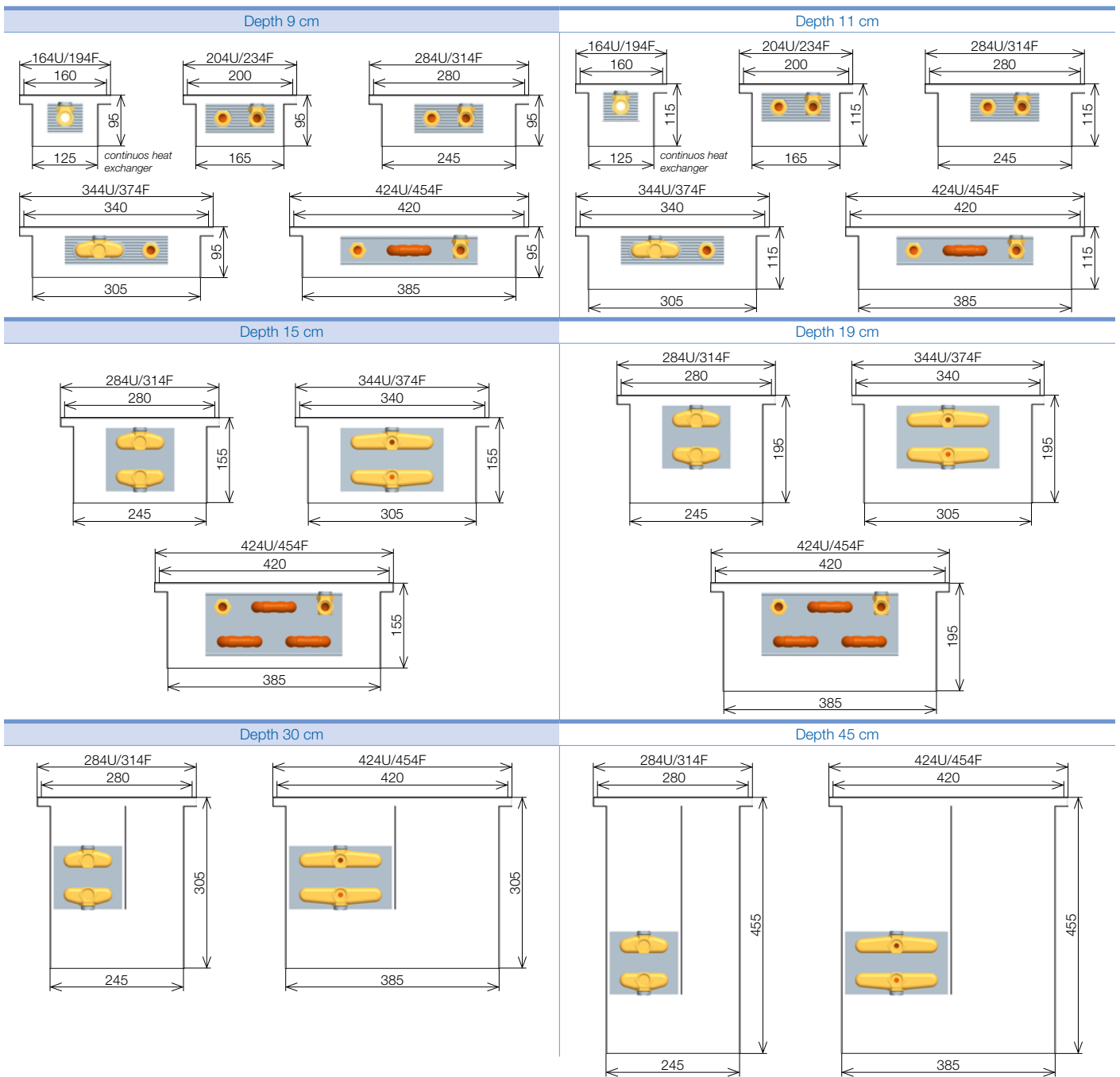

Heat exchanger placement

Standard design

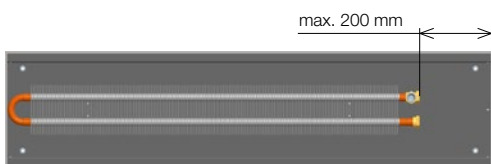

The specified dimensions do not include the decorative frame.

Koraflex FK InPool (pool version)

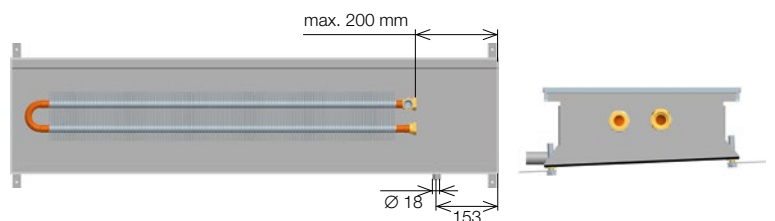

Suitable for interiors with increased humidity, must be fitted with Al or Stainless steel Cross grid, see page 19 and 22 • Pool design available only in depths 9 and 11 and widths 20, 28, 34 and 42 cm

• Not possible to connect cases from more KORAFLEX FK InPool convectors.



Heat outputs (W) at t1/t2/ti = at 75/65/20 °C ($\Delta t=50$) and 65/55/20 °C ($\Delta t=40$)/EN 442

Depth (cm)	Δt	Length L (cm)												
		80	100	120	140	160	180	200	220	240	260	280	300	
Width 16	9	Δt 50	87	121	156	191	226	260	295	330	364	399	434	469
		Δt 40	65	91	117	143	169	195	221	247	273	299	325	351
	11	Δt 50	100	140	180	220	260	300	340	380	420	460	500	540
		Δt 40	75	105	135	165	195	224	254	284	314	344	374	404
Width 20	9	Δt 50	110	154	197	241	285	329	373	417	461	505	549	592
		Δt 40	82	115	148	181	213	246	279	312	345	378	410	443
	11	Δt 50	127	178	229	280	330	381	432	483	534	584	635	686
		Δt 40	95	133	171	209	247	285	323	361	399	437	475	513
Width 28	9	Δt 50	161	226	290	355	419	484	548	612	677	741	806	870
		Δt 40	121	169	217	265	314	362	410	458	506	555	603	651
	11	Δt 50	174	244	313	383	453	522	592	662	731	801	871	940
		Δt 40	130	182	234	287	339	391	443	495	547	599	651	703
	15	Δt 50	245	344	442	540	638	736	834	932	1031	1129	1227	1325
		Δt 40	184	257	330	404	477	551	624	698	771	845	918	991
	19	Δt 50	267	374	480	587	694	801	908	1014	1121	1228	1335	1441
		Δt 40	200	280	359	439	519	599	679	759	839	919	999	1078
	30	Δt 50	313	439	564	690	815	940	1066	1191	1317	1442	1567	1693
		Δt 40	235	328	422	516	610	704	797	891	985	1079	1173	1266
	45	Δt 50	483	676	870	1063	1256	1449	1642	1836	2029	2222	2415	2609
		Δt 40	361	506	651	795	940	1084	1229	1373	1518	1663	1807	1952
Width 34	9	Δt 50	226	316	406	497	587	677	768	858	948	1039	1129	1219
		Δt 40	169	236	304	372	439	507	574	642	709	777	845	912
	11	Δt 50	242	339	436	533	630	727	824	921	1018	1115	1212	1308
		Δt 40	181	254	326	399	471	544	616	689	761	834	906	979
	15	Δt 50	315	440	566	692	818	944	1070	1196	1321	1447	1573	1699
		Δt 40	235	330	424	518	612	706	800	895	989	1083	1177	1271
	19	Δt 50	360	503	647	791	935	1079	1223	1367	1510	1654	1798	1942
		Δt 40	269	377	484	592	700	807	915	1022	1130	1238	1345	1453
Width 42	9	Δt 50	318	445	573	700	827	954	1081	1209	1336	1463	1590	1718
		Δt 40	238	333	428	524	619	714	809	904	1000	1095	1190	1285
	11	Δt 50	337	472	606	741	876	1011	1146	1280	1415	1550	1685	1819
		Δt 40	252	353	454	555	655	756	857	958	1059	1160	1260	1361
	15	Δt 50	433	606	779	952	1125	1298	1471	1644	1817	1990	2163	2337
		Δt 40	324	453	583	712	842	971	1101	1230	1360	1489	1619	1748
	19	Δt 50	471	660	848	1037	1225	1413	1602	1790	1979	2167	2356	2544
		Δt 40	353	494	635	776	917	1058	1199	1340	1481	1622	1763	1904
	30	Δt 50	546	765	983	1202	1420	1638	1857	2075	2294	2512	2731	2949
		Δt 40	409	572	736	899	1062	1226	1389	1553	1716	1880	2043	2207
	45	Δt 50	759	1063	1367	1670	1974	2278	2581	2885	3189	3492	3796	4100
		Δt 40	568	795	1022	1250	1477	1704	1931	2159	2386	2613	2840	3067

- temperature exponent $m = 1.3$

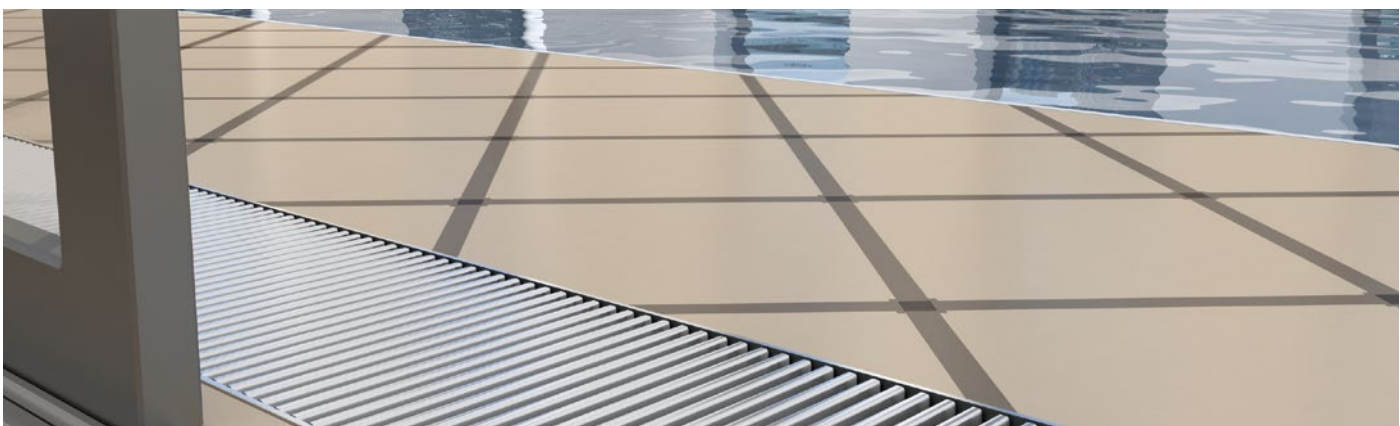

Correction factor k_t for a variant temperature difference Δt (K)

Δt (K)	18	19	20	21	22	23	24	25	26	27	28	29	30	31	32	33
k_t	0.265	0.284	0.304	0.324	0.344	0.364	0.385	0.406	0.427	0.449	0.471	0.493	0.515	0.537	0.560	0.583
Δt (K)	34	35	36	37	38	39	40	41	42	43	44	45	46	47	48	49
k_t	0.606	0.629	0.652	0.676	0.700	0.724	0.748	0.773	0.797	0.822	0.847	0.872	0.897	0.923	0.948	0.974
Δt (K)	50	51	52	53	54	55	56	57	58	59	60					
k_t	1.000	1.026	1.052	1.079	1.105	1.132	1.159	1.186	1.213	1.240	1.267					

- temperature exponent $m = 1.3$

For the formula and example of conversion for a variant temperature difference see page 93.

Weights and water volumes of floor convectors

steel type	9/16	9/20	9/28	9/34	9/42	11/16	11/20	11/28	11/34	11/42	15/28	15/34	15/42	19/28	19/34	19/42	30/28	30/42	45/28	45/42
kg/linear meter	4.1	5.12	5.96	7.24	8.47	4.43	5.54	6.4	7.7	9	8.59	10.53	12	9.47	11.5	12.96	13.9	18.45	17.7	22.3
stainless steel kg/linear meter	–	5.07	5.94	7.24	8.5	–	5.47	6.36	7.7	9	–	–	–	–	–	–	–	–	–	–
l/linear meter	0.18	0.4	0.4	0.6	0.8	0.18	0.4	0.4	0.6	0.8	0.8	1.2	1.6	0.8	1.2	1.6	0.8	1.2	0.8	1.2

The listed weights are without a packaging.

Aluminium frame profiles

Standard design – U frame

Standard design contains silver U profile. Profile colour is equal with grid colour, for other colours see page 19.

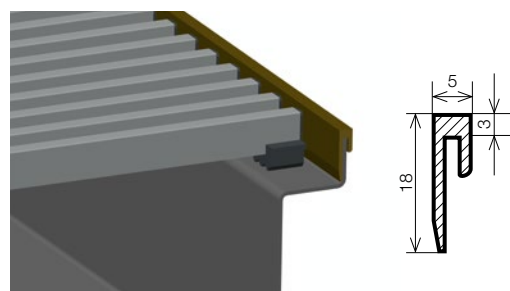

Selectable version – F frame

When the selectable frame F is ordered, it is attached separately to convector (not installed on convector). Frame colours are identical with aluminium grid colours.

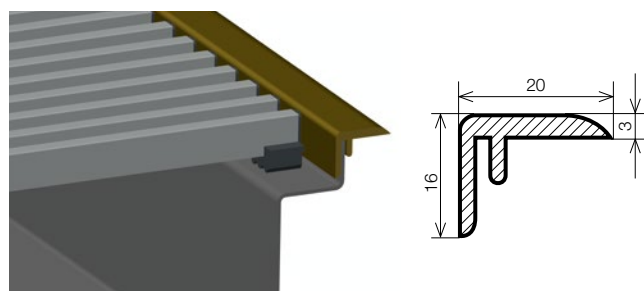

Frame colour is equal with grid colour presented on page 19.

The sketches dimensions are given in mm.

Convector breakdown

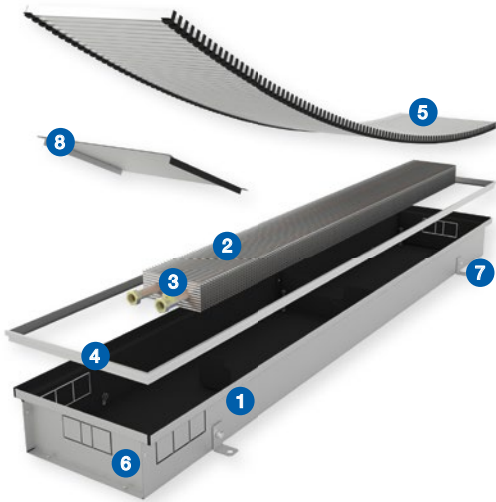

- 1 convector case according to the selected material
- 2 heat exchanger
- 3 air vent
- 4 cover frame (U or F)
- 5 floor grid
- 6 connecting holes
- 7 fixing anchors
- 8 covering metal sheet

Connecting the floor convectors KORAFLEX

Cases' types according to water inlets' location and lowering of faces for batch assembly

Lowering of the cases' faces is used where it is not desirable to see the connections between the convectors (long rows of convectors,

i.e. administrative buildings, hotels etc.). When ordering the walkable grid it is necessary to mention that it is the PM, which will be used for the convector with the lowered face.



Note: The Koraflex FK InPool convectors' individual cases cannot be mutually interconnected. These are made only in P0 design.

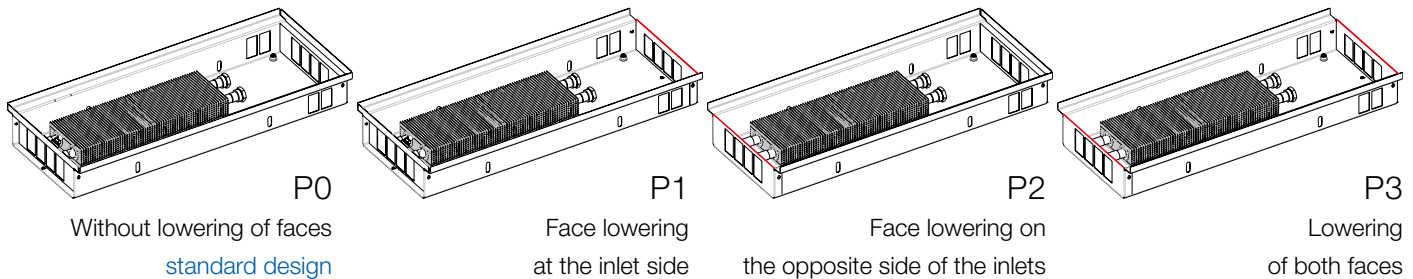

Connection dimensions

FK 9/16, 11/16: A = 4 cm
 FK 9/20, 9/28, 11/20, 11/28: A = 11 cm
 FK 9/34, 11/34: A = 22 cm
 FK 9/42, 11/42, 15/42, 19/42: A = 16 cm

FK 15/28, 15/34, 19/28, 19/34, 45/28, 45/42: A = 3 cm
 FK 30/28, 30/42: A = 12 cm

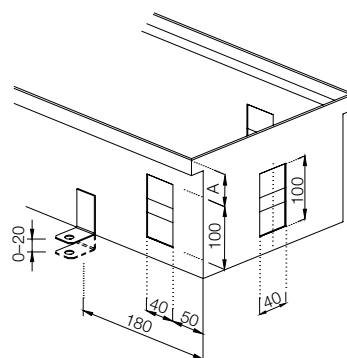
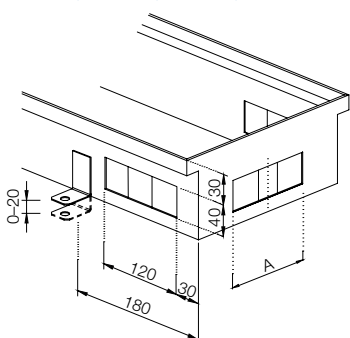

The sketches dimensions are given in mm.

Convector installation KORAFLEX

Building recommendation

Several general principles must be fulfilled for proper function of the convector.

- To interconnect the exchanger and the distributing pipeline, the standard stainless-steel hoses with stainless-steel jacketing must be used (unless recommended otherwise) which always form a part of the delivery. In practice they provide a better access under the heat exchanger without having to dismantle the heating system, e.g. during cleaning.
- A correctly installed convector is mounted horizontally and the top edges of the convector case are not warped or deflected to ensure proper functioning of the walk-on grid and allows venting of the heat exchanger.
- Correctly installed convector's decorative frame at the floor covering is within the margin of +2 mm.
- We recommend to keep the cover board in its place for the full duration of the building work to prevent dirt getting inside

the convector. The standard board supplied is not walkable. A higher load bearing capacity board can be ordered.

- The height adjustment screws are only used for horizontal leveling of the convector case.
- During concreting the convector must be fixed to the floor with the use of fixing anchors screws that will prevent vertical shifting of the convector during subsequent pouring of concrete. The convector can be vertically loaded during concrete pouring. During concreting the convector must be strutted to prevent deformation of the case. When using other casting material (e.g. anhydride) seal thoroughly all passages into the convector to prevent it from flooding.
- Convectors with stainless steel case, designed for humid environments and identified as KORAFLEX FK InPool have a standard built-in water drainage. It must be interconnected during the installation with a pipe with secured slope to drain the waste water. We recommend to fit the drain with the odour trap.
- For further versions for KORAFLEX FK built-in see page 71 (Possibility to imbed in floors according to floor types).

Cross section of the correct embedding and location of the convectors

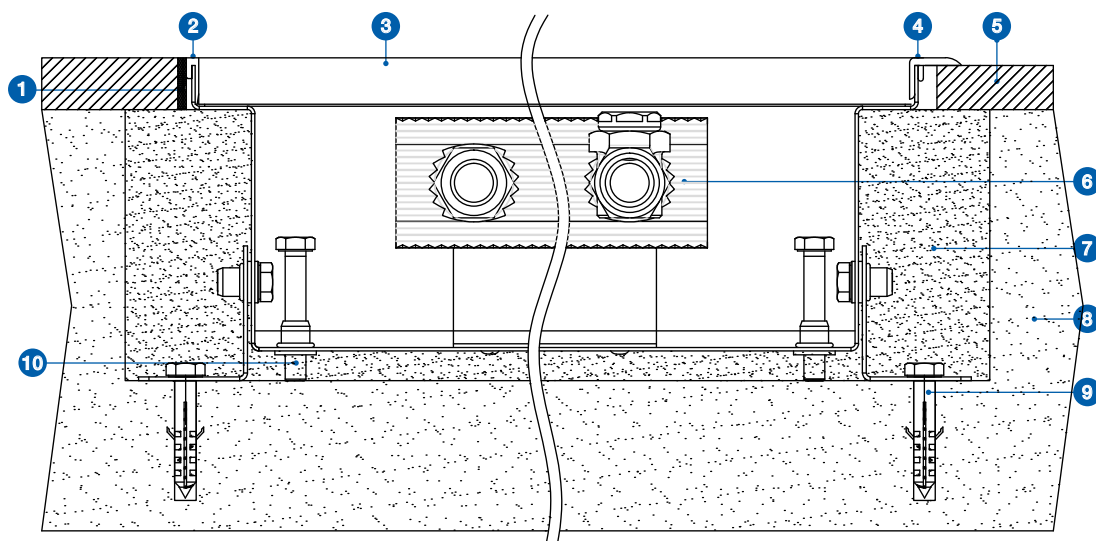

- 1 jointing material (silicon)
- 2 U frame
- 3 walkable grid
- 4 F frame
- 5 floor covering
- 6 exchanger
- 7 concrete fill
- 8 subfloor
- 9 fixing anchor
- 10 height adjustment screw

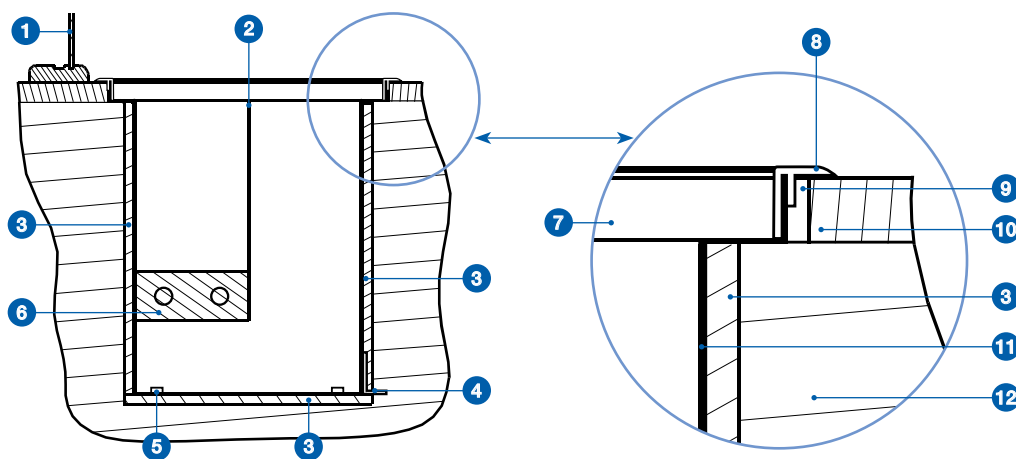

- 1 window
- 2 partition
- 3 insulation
- 4 fixing anchor
- 5 height adjustment screw
- 6 exchanger
- 7 lamella of the grid
- 8 decorative frame
- 9 expansion joint
- 10 floor covering
- 11 metal plating
- 12 subfloor

Recommended location of the heat exchanger KORAFLEX FK depth 30 and 45 cm



Location of the exchanger at the room side

Descending stream of cool air enters the convector case. The rising flow of heated air then supports natural air circulation in the room and creates a screen in front of the window area. This arrangement is suitable in rooms where the convector is the only heating source and where the share of window heat losses in the total heat loss of the room is about 70–100 %.

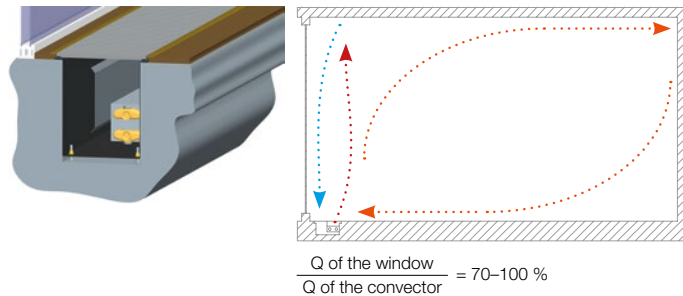

Location of the exchanger at the window side

This location is suitable in rooms where heat losses on the part of the room prevail and there is only a small share of window losses (20 % at the most). The distance between the convector and the window must be as small as possible.

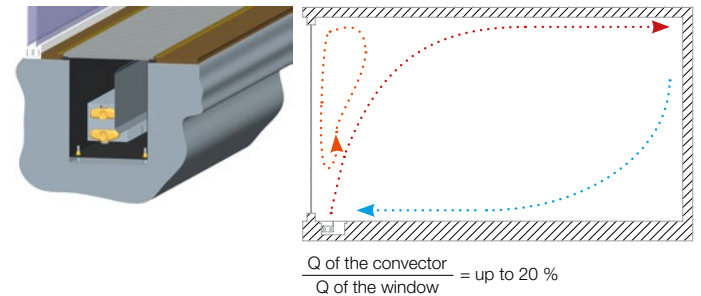

Ordering codes KORAFLEX FK • KORAFLEX FK InPool

			Length (cm)	Depth (cm)	Width (cm)		Location of supply water (case type) P on the right (looking out of room)			Frame finish 0 not fitted with a frame* 1 aluminium/silver 2 aluminium/bronze* 3 aluminium/light bronze*		
Economic	black steel case/unpainted exchanger	FKE	-	N	P	0	R	U	1
Exclusive*	black steel case/black exchanger	FKX	-	N	P	0	R	U	1
Inox*	stainless steel case AISI 304/unpainted exchanger	FKI	-	N	P	0	R	U	1
InPool*	stainless steel case AISI 316/unpainted exchanger	FKP	-	N	P	0	R	U	1

* custom-made design KORAFLEX FK InPool cannot be mutually interconnected	Floor convectors KORAFLEX FK	Convector case's face finish 0 without lowering of faces 1 lowering face on the supply side* 2 face lowering on opposite side of the supply* 3 lowering of both faces*	Grid design R lateral L longitudinal*	Frame type N not fitted with a frame* U U profile F F profile*
--	---------------------------------	---	---	--

Ordering example

KORAFLEX FK, length 120 cm, depth 11 cm, width 34 cm with the black exchanger and F shape frame, bronze eloxal coat = Exclusive Finish

Ordering code – FKX1201134-NP0RF2

If the order does not specify the decorative frame, design of the case and the heat exchanger, the body will be made of black coated steel sheet with silver exchanger, and fitted with a silver frame in the shape of U.

Floor convectors' design finishes KORAFLEX

Specifications

corner (angle) parts maximum design depth (cm)	7
arch design depth (cm)	8, 9, 11, 15 and 19
production possibilities must be evaluated individually	
case design	black zinc galvanised steel
grid design	aluminium, wood, stainless steel
the floor grid must be always ordered together with the design convector	

To ensure a perfect interconnection of floor convectors KORAFLEX in the rooms' corners it is best to use corner parts RD. The corner piece comes complete with a corner cover grid piece for all offered versions, see page 18.

The corner piece has no effect on the heat performance of the heating body and only serves as a visual complement. The corner pieces must be ordered together with the adjacent floor convectors including PM. No heat exchanger can be placed in the corner part, therefore it does not heat.

Corner



Arch

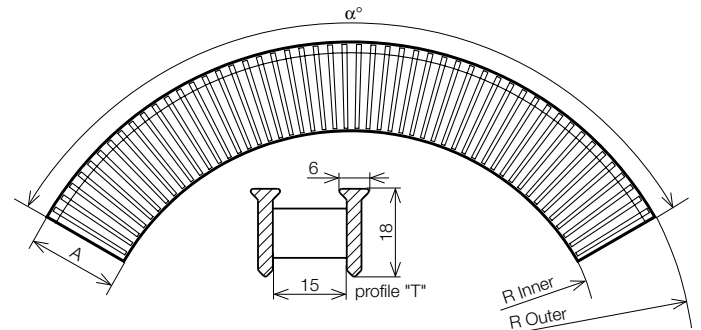
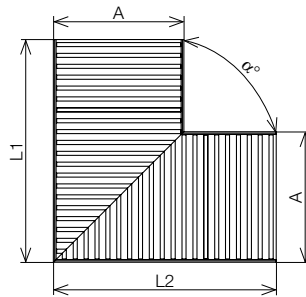
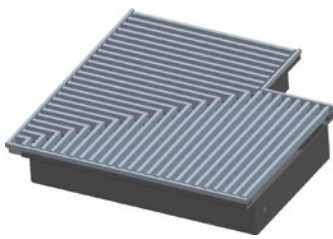

Dimensional series

width of channel A (cm)	16	20	28	34	42
length L1, L2 (cm)	20	30	40	50	50

The minimum internal radius of the arc version must be more than 300 cm. Use type "T" profile aluminium grids on a spring when fitting the arch version with the aluminium grids, see image and U frame. (F frame could not be used due to design reasons).

Ordering codes for corner part of KORAFLEX

FR*	P	-	R	10	1	U	1	0
<p>Ordering example: The corner part length 30 cm, depth 7 cm, width 20 cm with aluminium lateral light bronze cover and U profile bronze.</p> <p>FRP300720-R111U20</p> <p>* custom-made design</p>											
Type of angle P Right angle* S Another angle*		Material and colours of lamellas 10 aluminium silver 11 aluminium bronze 12 aluminium light bronze 20 beech 21 oak 22 mahogany				Grid design R lateral L longitudinal		Frame type N not fitted with a frame* U U profile F F profile*		Frame finish 0 not fitted with a frame* 1 aluminium/silver 2 aluminium/bronze* 3 aluminium/light bronze*	
Lamellas' joint design 0 no joint (PM Cross) 1 black plastic strip (PM AL) 2 black joint (wood) 3 beige joint (wood) 4 stainless steel for dry environment		Surface finish of the lamellas 0 without any finish 1 clear varnish coat*									



It is necessary to consult custom-made designs with the manufacturer before sending the order. Heat outputs can not be in any way guaranteed, the manufacturer may on request carry out an expert estimate of the possible heat output. To order a corner design you must specify the angle α and the total width (A), which must

correspond with the widths of the produced floor mounted cases. It is necessary to specify the angle α for all shapes, including the arched design, and the inner or outer radius (R – inner, R – outer) and the overall width (A) that must correspond with the widths of the produced floor mounted cases.

Corner Z

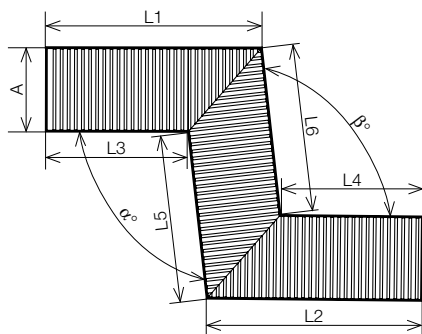

Corner U

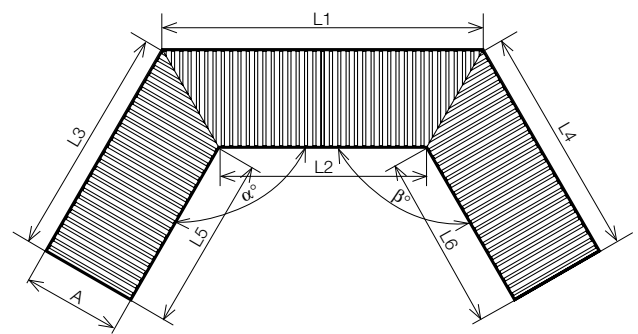

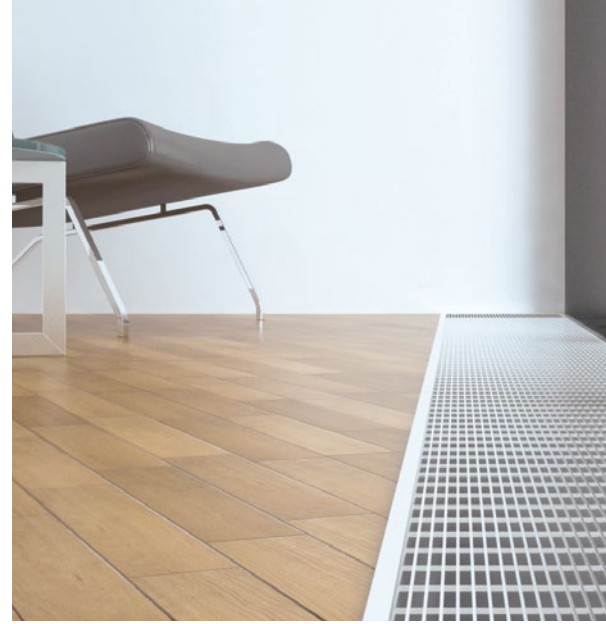

[KORAFLEX PM

COVER GRIDS of the floor convectors KORAFLEX

Take care with every detail and choose from a wide range of cover grids of the floor convectors, so that they are the top complement of the interior. Intentionally visible or quietly blending into its environment. The grids are the same for all types of the floor convectors KORAFLEX. Wide selection of lengths, special surface finishes in the rolling or longitudinal designs.

Grid eloxal coat finish Aluminium



Lateral



Longitudinal*

* The frame is not part of the cover grid but part of the floor convector

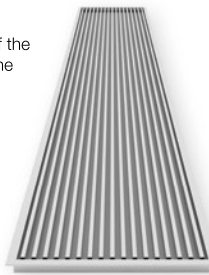

Supporting elements under the longitudinal grid

If you order a longitudinal Aluminium cover grid, the supporting elements will be included in the grid package.



Version elox is designed for dry and humid environment.

Colour availability of aluminium grids



aluminium/silver



aluminium/bronze

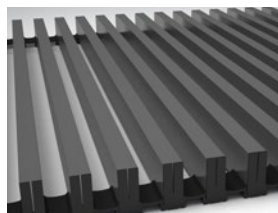

aluminium/light bronze

The floor grids are made of natural materials and therefore minor deviations in the colour design cannot be eliminated. The supplier cannot fully guarantee the presented colours and accept complaints for the reason of possible colour deviations.

Permeability 66 %

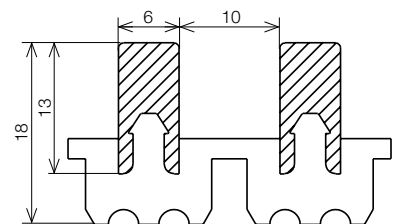

Dimensions in mm

Ordering codes Aluminium grids

			Length (cm)	Width (cm)	Grid design	Material and colours of lamellas		Lamellas' joint design		
						R lateral	L longitudinal*	10 aluminium silver	11 aluminium bronze	12 aluminium light bronze
aluminium/silver	PM	-	-	R	10	1	0	0
aluminium/bronze	PM	-	-	R	11	1	0	0
aluminium/light bronze	PM	-	-	R	12	1	0	0

* custom-made design

Floor grids
KORAFLEX PM

Grid type for connected KORAFLEX FK

0 grid designed for the case type P0 or for the first convector in the connected cases assembly
2 grid designed for the second and every subsequent convector in the connected cases assembly*

Surface finish of the lamellas
0 without any finish

Grids design Wood



Colour availability of wooden grids



beech

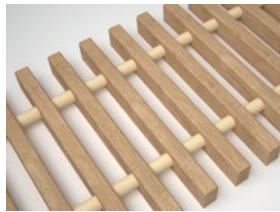

oak



mahogany

Permeability 60 %

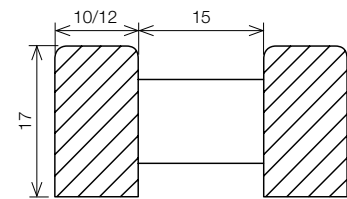

Dimensions in mm

The floor grids are made of natural materials and therefore minor deviations in the colour design cannot be eliminated. The supplier cannot fully guarantee the presented colours and accept claims due to possible colour deviations.



Ordering codes Wooden grids

			Length (cm)	Width (cm)							
beech	PM	-	-	R	20	3	0	0	
oak	PM	-	-	R	21	3	0	0	
mahogany	PM	-	-	R	22	2	0	0	

* custom-made design

Floor grids
KORAFLEX PM

Grid design
R lateral

Lamellas' joint design

- 2 black spacer (standard only for mahogany)
- 3 beige spacer (standard only for beech and oak)

Surface finish
of the lamellas

- 0 without any finish
- 1 clear varnish coat*

Material and colours
of lamellas

- 20 beech
- 21 oak
- 22 mahogany

Grid type for connected KORAFLEX FK

- 0 grid designed for the case type P0 or for the first convector in the connected cases assembly
- 2 grid designed for the second and every subsequent convector in the connected cases assembly*

Grids design Stainless steel Roll



Stainless steel Roll – lateral design

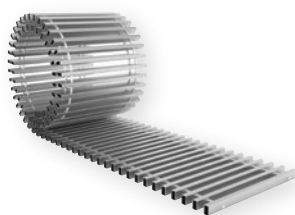

Stainless steel Roll – longitudinal design*

* The frame is not part of the cover grid but part of the floor convector

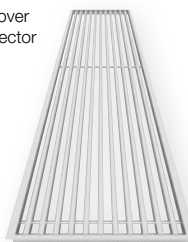

Supporting elements under the longitudinal grid

If you order a longitudinal Stainless steel Roll cover grid, the supporting elements will be included in the grid package.



The Roll design is suitable only for dry environment (material AISI 304)

Permeability 60 %

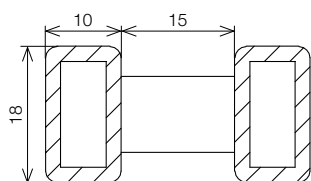

Dimensions in mm



The floor grids are made of natural materials and therefore minor deviations in the colour design cannot be eliminated. The supplier cannot fully guarantee the presented colours and accept claims due to possible colour deviations.

Ordering codes Floor grids • Roll

Material		Length (cm)		Width (cm)		Grid design		Grid type for connected KORAFLEX FK			
Material	Code	Length	Width	Grid design	Code	Grid type	Code	Grid type	Code	Grid type	Code
stainless steel for dry environment	PM	-	-	R	30	4	0	0	0
* custom-made design		Floor grids KORAFLEX PM Roll		Material of lamellas 30 stainless steel (for dry environment)		Lamellas' joint design 4 stainless steel (for dry environment)		Surface finish of the lamellas 0 without any finish			

Grids design Stainless steel Cross

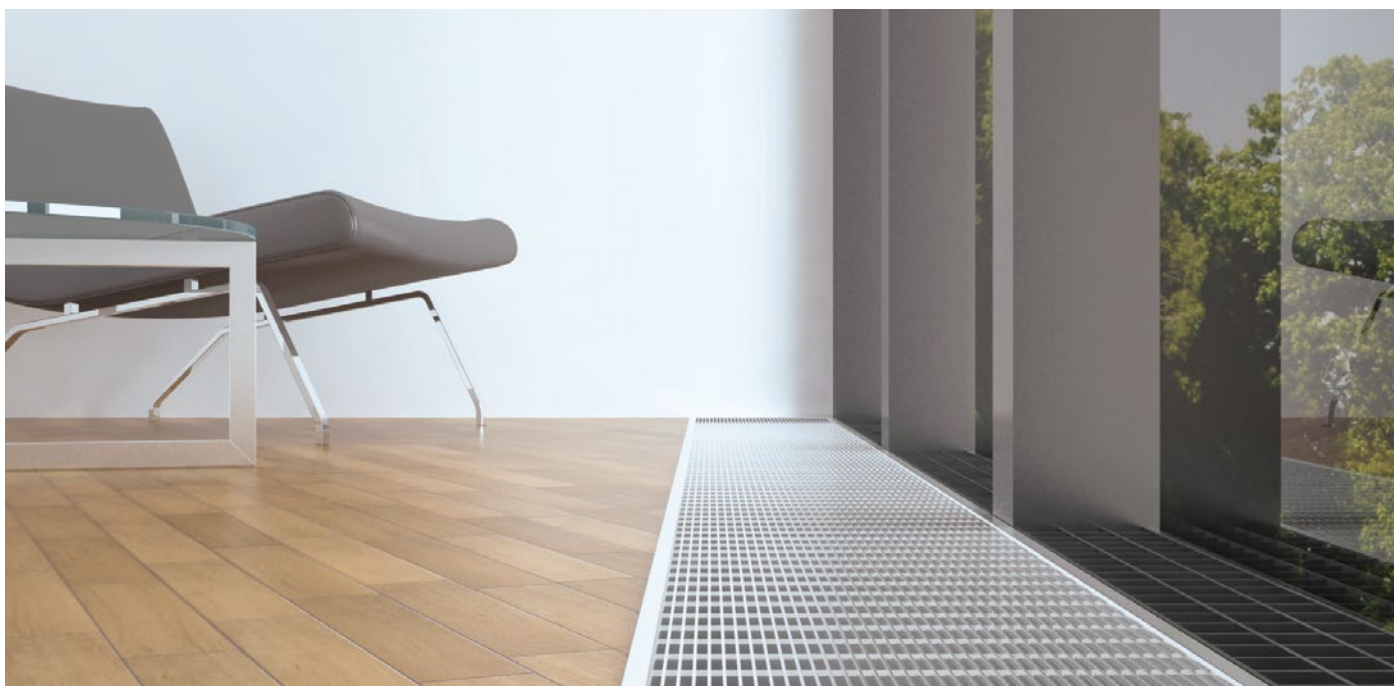

Stainless steel Cross*



* Ordering of the stainless steel Grids Cross is only possible with the appropriate convector

Permeability 63 %

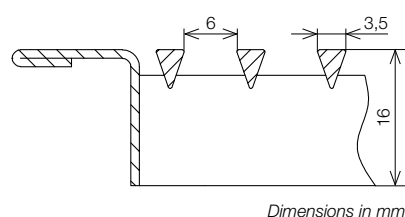

Luxury finish

The stainless steel grid including the decorative frame is of the same material as the walkable grid. High level of design, high load bearing capacity, possible choice of design:

- dry environment stainless steel AISI 304
- humid environment stainless steel AISI 316

 The cover grid stainless steel Cross is designed for the case type P0 (see page 13 and 68). The stainless steel Cross up to 2 m length is supplied in one piece; above 2 m the grid is divided.

Floor convectors including the grid intended for use in the pool area (AISI 316) must be kept clean and washed regularly with clean water and maintained with suitable preparations for the preservation of the stainless steel.

The floor grids are made of natural materials and therefore minor deviations in the colour design cannot be eliminated. The supplier cannot fully guarantee the presented colours and accept claims due to possible colour deviations.

Ordering codes Floor grids • Cross

	PM	-	-	L	40	0	0	0	Floor grid/case type		
											0 grid designed for the case type P0 or for the first convector in the connected cases assembly	2 grid designed for the second and every subsequent convector in the connected cases assembly*	
			Length (cm)	Width (cm)		Grid design L longitudinal	Material of lamellas 40 stainless steel suitable (for dry environment) 41 stainless steel suitable (for humid environment)						
Cross (for dry environment)*	PM	-	-	L	40	0	0	0			
Cross (for humid environment)*	PM	-	-	L	41	0	0	0			

* custom-made design

Floor grids
KORAFLEX PM Cross

Lamellas' joint design
0 without any finish (PM Cross)

Surface finish of the lamellas
0 without any finish

Cover grids load bearing capacity

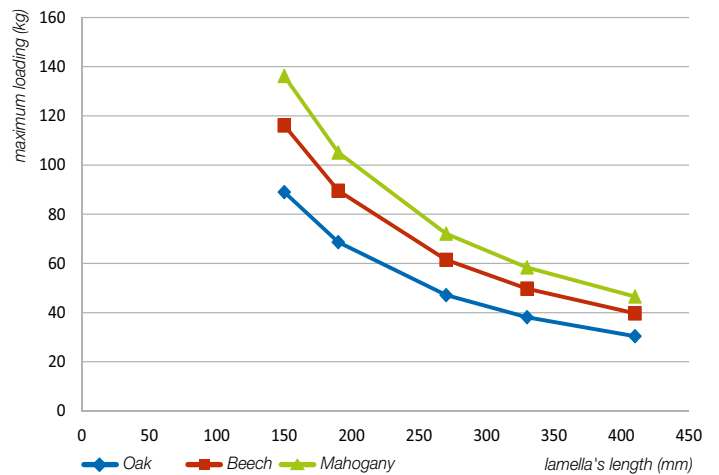
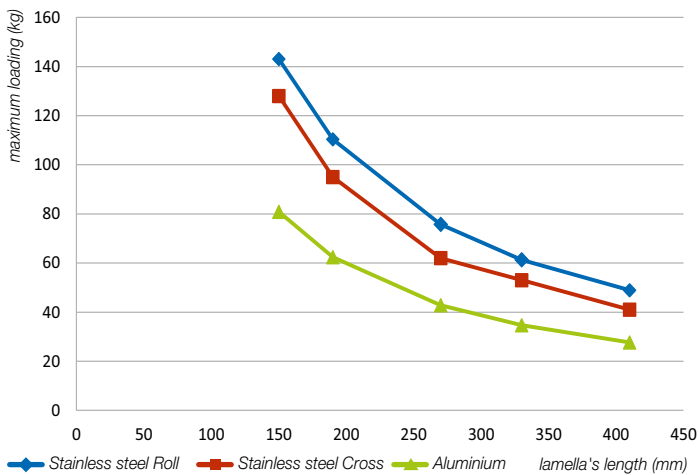

Point load on 1 grid lamella according to produced widths.

Correction factor per flow area of the grid

% of flow surface	> 75	60	50	40	30
correction factor	1.00	0.95	0.90	0.85	0.60

The flow surface means the flow surface of the heat exchanger (width × length of the radiator) minus the area of the cover grid (all dimensions given in %). The heat output of the particular convector is multiplied by this correction factor. Measurements of the KORAFLEX products performances include the cover grid, therefore no further recalculation is necessary.

Manufacturing dimensions of the cover grids

Code designation	PM-xx/16	PM-xx/20	PM-xx/28	PM-xx/34	PM-xx/42
Width	152 mm	192 mm	272 mm	332 mm	412 mm

tolerance +0-1,5 mm

Profiles of the aluminium frames

U frame

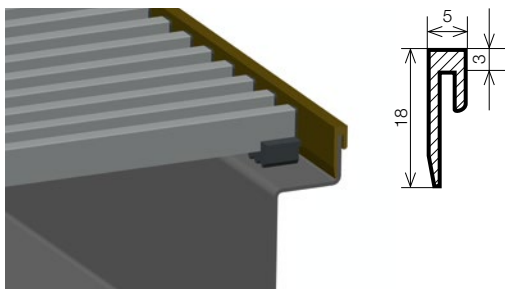

F frame

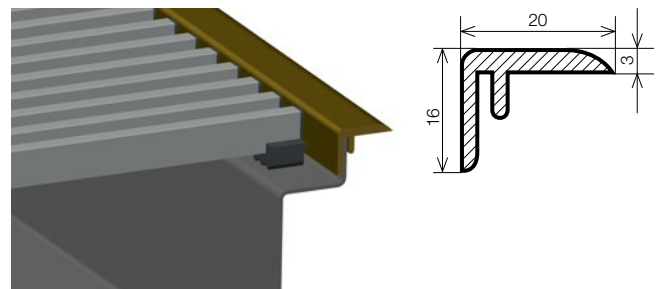

The sketches dimensions are given in mm.

The convectors are fitted as standard with the silver U profile; when frame F is ordered it is enclosed with the delivery. Colour finishes of the decorative frames match the colour finishes of the aluminium grids, see page 19.



[KORALINE

FREE STANDING CONVECTORS (natural convection)

Do you like large glass surfaces or are the interior window sills low? Use subtle and graceful shapes of the free standing convector. The design will let the windows stand out and provide a great view from the interior. Outstanding technical parameters ensure excellent thermal comfort in the room.

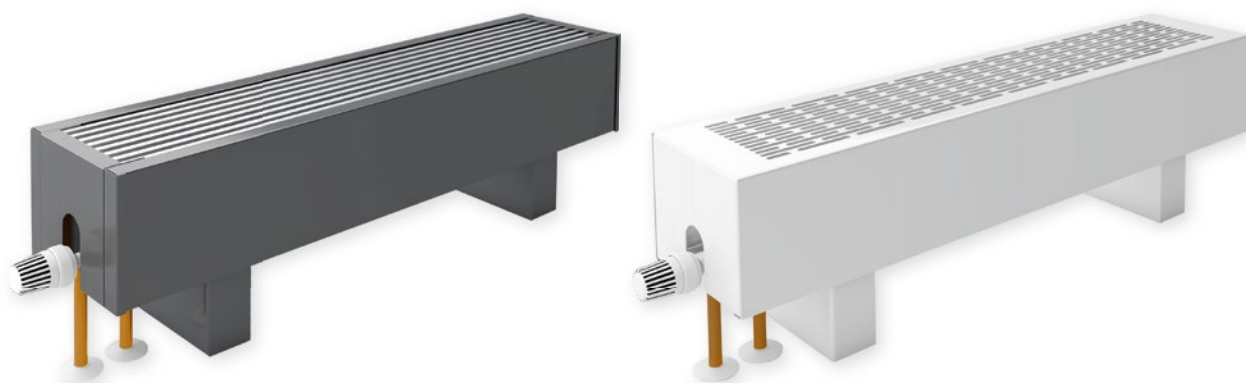

Free standing convectors with natural convection KORALINE LK

Classification of the free standing convectors

- **KORALINE LK Exclusive** design of zinc galvanised steel – with aluminium grid (silver eloxal coat) see image
- **KORALINE LK InPool** pool design – chemical proof stainless steel AISI 316 for wet environment coated in RAL 9010 colour shade
- **KORALINE LK Economic** zinc galvanised steel – design with embossed cover grid – see sketch (not available for pool applications)

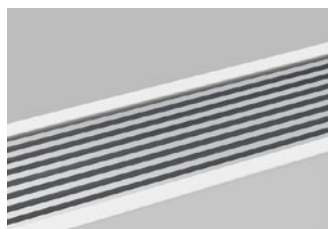

Version KORALINE LK Exclusive and LK InPool



Version KORALINE LK Economic

Standard delivery contains

- sheathing of zinc galvanised steel sheet coated in shade RAL 9010 – white
- unpainted aluminium cover grid, silver – in version Exclusive and InPool. On Economic (LKE) embossed in the free standing convector sheathing
- Al/Cu heat exchanger for universal connection (side or bottom) with low water content, air vent and uniquely shaped lamellas for a higher heat output
- stand on floor covering, see sketch on page 28
- the unit is packed in a durable packaging and contains an installation manual

KORALINE PLAN

Design version PLAN with completely flat front panel is available up to the height of 30 cm (only for versions KORALINE LK Exclusive and InPool).

Specification

casing element height (mm)	90, 150, 300, 450, 600
width (mm)	180, 240
length (mm)	800, 1 000, 1 200, 1 400, 1 600, 1 800, 2 000, 2 200, 2 400, 2 600, 2 800, 3 000
heat output (W)	from 385 to 3 435
max. working pressure (bar)	12
max. working temperature	110 °C
max. surface temperature	40 °C
connecting thread	inner G 1/2"
connection method	recommended bottom connection, side

Version **KORALINE LK Exclusive** • zinc galvanised steel sheet coated in colour shade RAL 9010 with aluminium anodized grid without surface finish

Version **KORALINE LK InPool** • chemical proof stainless steel AISI 316 for humid environment coated in RAL 9010 with aluminium anodized grid without surface finish

Version **KORALINE LK Economic** • zinc galvanised steel sheet coated in colour shade RAL 9010 with an embossed grid, which is part of the sheathing



Optional specification

- set for bottom connection comprising the thermostatic valve and the thermostatic head Danfoss including extension pieces, see page 29
- stands on subfloor or wall suspending brackets, see sketch on page 28
- if more than 5 pieces are ordered another colour shade can be chosen according to RAL scale (the change must be consulted with the manufacturer)
- pool design suitable for humid environment e.g. swimming pools areas
- pool design KORALINE LK InPool – using stainless steel AISI 316 coated in white colour shade RAL 9010
- for increased performance a version with forced convection can be chosen, see page 72

Elements' sections

Side connection

width	18 cm	18 cm	24 cm	24 cm
height	9 cm	15 cm	9 cm	15 cm

Bottom connection

width	18 cm	18 cm	24 cm	24 cm
height	9 cm	15 cm	9 cm	15 cm

Height without stands. KORALINE LK in version Exclusive and Economic mounted convectors are produced for versatile side/bottom connection. The connection type can be selected on site during installation. In the case of bottom connection the manufacturer recommends you to use a set that contains a Danfoss thermostatic valve and thermostatic head, incl. an extension adaptor. In case another valve type is used the connecting spacing of 50 mm between the input and output will not be achieved – it applies for the height of 15 cm; for the height of 9 cm, the spacing is according to the sketch, see the height (the dimensions are given in mm).

Sketches of KORALINE LK with stands on floor covering

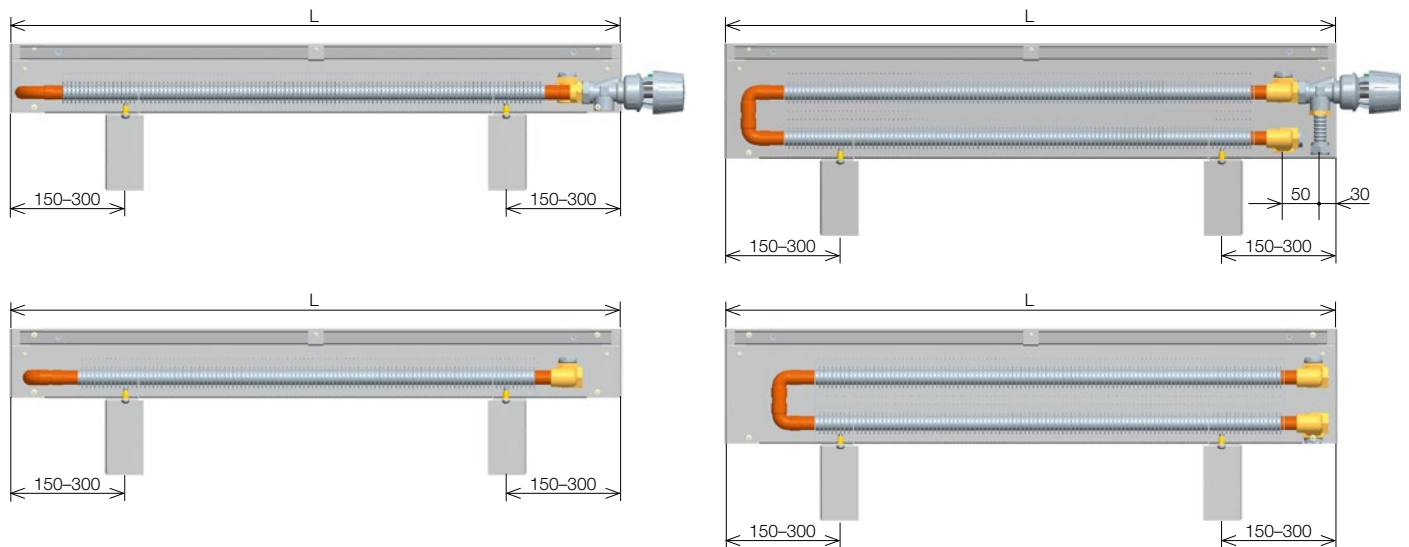

KORALINE LK in version Exclusive and Economic mounted convectors are supplied with stands on floor covering as standard. Another possibility of anchoring to the building structure is the use of stands on subfloor or the use of wall brackets (see the illustration on page 28). Dimensions are given in mm.



For more detailed dimensional sketches including calculating the stands' distances see page 28.

Weights and volumes of water of the free standing convectors

Type	9/18	9/24	15/18	15/24	30/18	30/24	45/18	45/24	60/18	60/24
kg/linear meter	6.5	8.1	9.2	11.5	12.9	15.4	16.7	19.2	20.5	23.1
stainless steel kg/linear meter	7	8.7	10	12.4	14.5	17.1	19	21.8	23.6	26.4
l/linear meter	0.5	0.75	1	1.6	1	1.6	1	1.6	1	1.6

The listed weights are without a packaging.



Heat outputs (W) at $t_1/t_2/t_i =$ at $75/65/20\text{ }^\circ\text{C}$ ($\Delta t=50$) and $65/55/20\text{ }^\circ\text{C}$ ($\Delta t=40$)/EN 442

Width (cm)	Δt	Length L (cm)												
		80	100	120	140	160	180	200	220	240	260	280	300	
Height 9	18	Δt 50	385	508	631	754	877	1001	1123	1246	1369	1492	1615	1738
		Δt 40	288	380	472	564	656	749	840	932	1024	1116	1208	1300
	24	Δt 50	574	757	940	1123	1307	1491	1673	1855	2038	2221	2404	2587
		Δt 40	429	566	703	840	977	1116	1252	1388	1524	1661	1798	1935
Height 15	18	Δt 50	589	743	897	1052	1207	1362	1517	1671	1826	1980	2135	2290
		Δt 40	440	555	671	787	903	1019	1134	1250	1366	1481	1597	1713
	24	Δt 50	916	1145	1374	1603	1833	2061	2290	2519	2748	2977	3206	3435
		Δt 40	685	856	1028	1199	1371	1542	1713	1884	2056	2227	2398	2569
Height 30	18	Δt 50	760	950	1140	1330	1520	1710	1900					
		Δt 40	568	711	853	995	1137	1279	1421					
	24	Δt 50	1112	1390	1668	1946	2224	2502	2780					
		Δt 40	832	1040	1248	1456	1664	1871	2079					
Height 45	18	Δt 50	857	1071	1285	1499	1714	1927	2141					
		Δt 40	641	801	961	1121	1282	1441	1601					
	24	Δt 50	1274	1593	1911	2230	2549	2869	3188					
		Δt 40	953	1192	1429	1668	1907	2146	2385					
Height 60	18	Δt 50	934	1168	1401	1635	1870	2104	2338					
		Δt 40	699	874	1048	1223	1399	1574	1749					
	24	Δt 50	1374	1717	2060	2403	2746	3089	3432					
		Δt 40	1028	1284	1541	1797	2054	2311	2567					

- The free standing convectors KORALINE LK Economic are made only in height of 9, 15 and 30 cm and the 18 and 24 cm widths

Correction factor k_t for a variant temperature difference Δt (K)

Δt (K)	20	22	24	26	28	30	32	34	36	38	40	42	44	46	48	50
k_t	0.287	0.326	0.367	0.410	0.453	0.498	0.544	0.591	0.639	0.688	0.737	0.788	0.839	0.892	0.946	1.000

Δt (K)	52	54	56	58	60	62	64	66	68	70	72	74	76	78	80
k_t	1.055	1.111	1.167	1.224	1.282	1.341	1.401	1.460	1.521	1.582	1.644	1.676	1.770	1.834	1.898

See the formula and example of conversion to a variant temperature difference on page 93.

- temperature exponent $m = 1.364$

Heights of the free standing convectors KORALINE LK

KORALINE LK Exclusive

KORALINE LK Economic

(maximum height 300 mm)

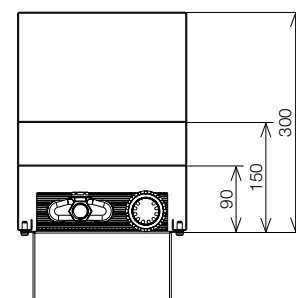
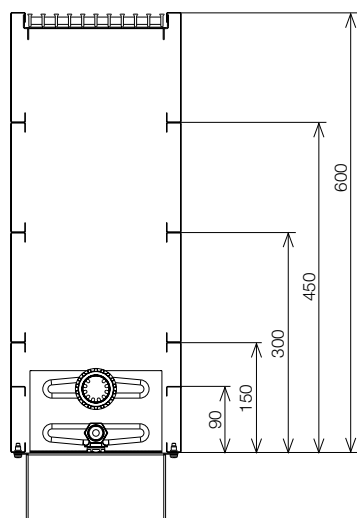

Free standing convectors installation KORALINE LK

Installation instructions

Stand models

a) **stand type** – attachment to the floor. Stands on rough and floor covering can be chosen. The subfloor version allows a height tolerance of about 5 cm. The floor mounting spacing is given on the sketch.

b) **wall mounted** – attachment to the wall. Recommended positioning 10 cm above the floor covering. The delivered brackets (2 pieces) allow a height and length tolerance of approx. 2 cm. The mounting spacings are indicated on the sketch.

Installation procedure (valid for all models)

The first step consists in measurement and drilling for the brackets or stands. The heat exchanger is then positioned and connected to the heating system. Finally, the cover with the cover grid is put on and screwed onto the brackets or the stands. The free standing convectors KORALINE LK Exclusive and InPool grids are removable for easy cleaning. More detailed information is available in the installation instructions. The elements are supplied assembled.

Free standing convectors assembly

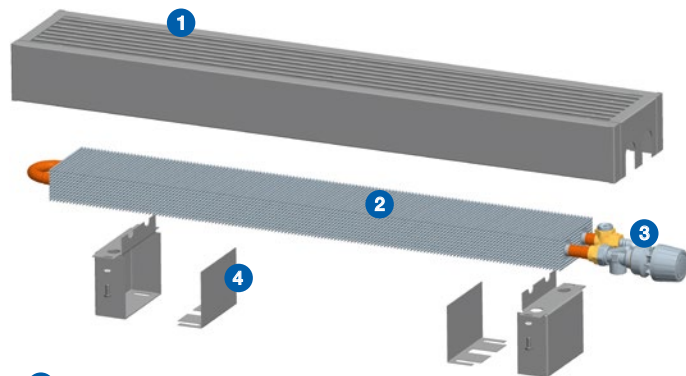

- 1 cover with the cover grid
- 2 Al/Cu heat exchanger
- 3 Thermostatic head + valve
- 4 stand + stand cover



Note: For better stability, we recommend attaching the free standing convectors on the brackets (convectors up to the height of 30 cm).

Mounting location

Floor anchoring diagram

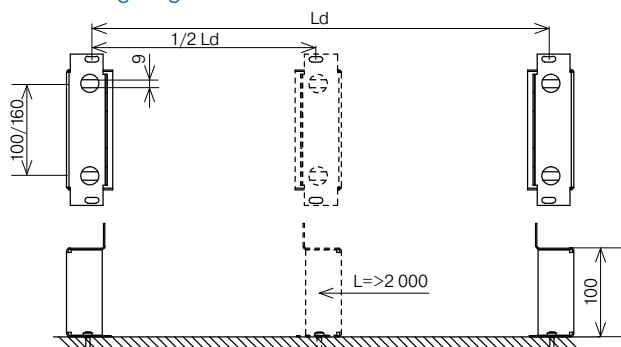

L = Convector length

Ld = L - 300 mm (up to the convector length of 1 400 mm)

Ld = L - 400 mm (up to the convector length of 2 000 mm)

Ld = L - 600 mm (above the convector length of 2 000 mm)

Wall anchoring diagram

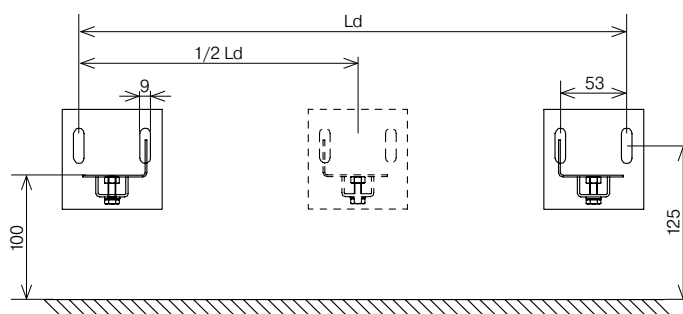

L = Convector length

Ld = L - 247 mm (up to the convector length of 1 400 mm)

Ld = L - 347 mm (up to the convector length of 2 000 mm)

Ld = L - 547 mm (above the convector length of 2 000 mm)

Overview of stands and brackets for free standing convectors KORALINE attachment

width 18 cm	width 24 cm	width 18 cm	width 24 cm	width 18 cm	width 24 cm
wall mounted brackets		floor covering stand*		subfloor stand	

After suspending the free standing convector the distance between the wall and the element is 10–30 mm.

* part of supply

Contents of the set for connection of KORALINE LK Kv values for the Danfoss RA-N 15 UK 1/2" valve



RA-N 15 valve

- thermostatic valve
Danfoss RA-N 15 1/2" (Specially adjusted for free standing convectors)
- valve body allowing presetting of flow
- flow can be set without using tools
- basic setting is selectable in 7 stages
- maximum working pressure 10 bar
- maximum working temperature 120 °C
- threadless connection with the thermostatic head



Thermostatic head

- thermostatic gas-steam head
Danfoss RA 2980
- the fastest response time
- anti-theft lock
- temperature setting limiting/blocking pins



Extension pieces

- used for height compensation between the input and output of the heat exchanger screw union
- stainless-steel design
- connection thread G 1/2", inner
- A straight piece for two row exchangers
(height of the free standing convector 15 cm and more)
- B angled piece for single-row exchangers
(height of the free standing convector 9 cm)

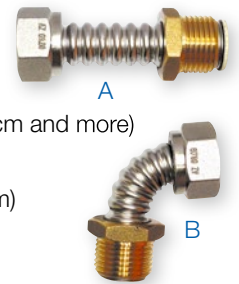

Preset stage	1	2	3	4	5	6	7	N
Kv	0.16	0.20	0.25	0.36	0.47	0.59	0.74	0.81

This valve type is used in optional accessories supplied for the free standing convectors.

Note: The connecting set elements are packed as a complete set and cannot be supplied separately.

Ordering codes Free standing convectors KORALINE LK

	Type K natural convection P PLAN*1	Versions X Exclusive P InPool E Economic	Length (cm)	Height (cm)	Width (cm)	Colour
Exclusive	white steel/unpainted exchanger	X	- 10
InPool*	stainless steel for humid environment white/unpainted exchanger	P	- 10
Economic	white steel/unpainted exchanger	E	- 10

*1 P PLAN from one steel sheet
(only for KORALINE LK Exclusive
and LK InPool heights 30, 45, 60)

Free standing convectors
KORALINE LK

* custom-made design

Note: For free standing convectors of more than 2 m in length we recommend installing 2 pairs of stands on a subfloor, or alternatively 2 pairs of wall brackets.

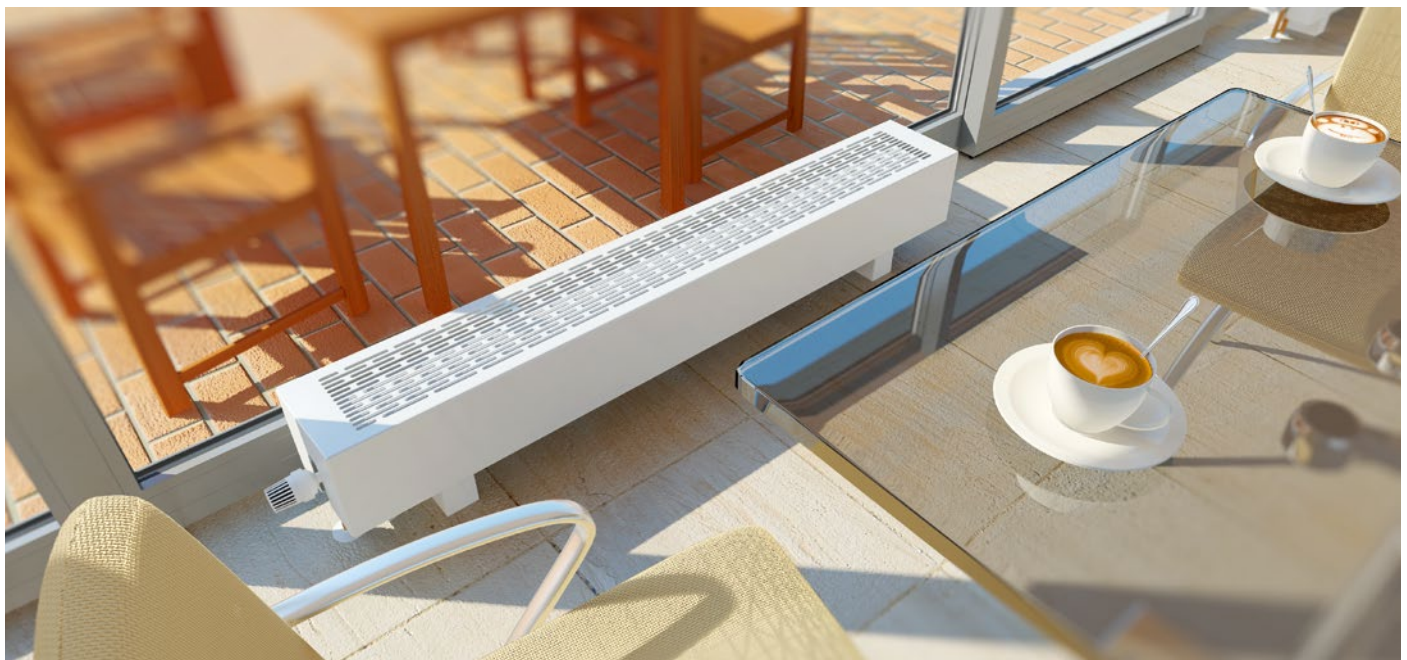

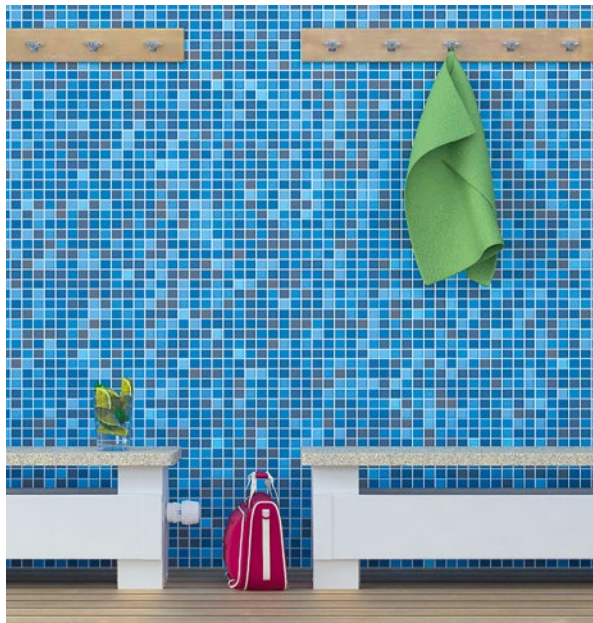

KORALINE with desk

HEATING BENCHES WITH DESK (natural convection)

For heating and rest? Yes. Just sit back, rest, relax or just wait. For benches with top desk made of solid oak, beech or of artificial stone a load is no problem. Proven clever combination of design, performance and utility features will be appreciated in the implementation of residential development and public spaces.



Natural convection heating benches with desk KORALINE LD

KORALINE LD Exclusive was designed for premises intended for relaxation. The bench is fitted with a covering desk that can withstand static load without problems and is also suitable to sit on. Attention, the covering desk must be ordered separately. The desks are positioned on the convector and fixed to the convector structure. The KORALINE LD Exclusive convector can be installed for example in halls or winter gardens. For use in pool areas we recommend the order is placed for complete stainless steel finish – so called pool version.

- natural convection convectors
- wide range of types and designs offered
- easy to clean and maintain

Standard delivery contains

- steel sheathing, coated in colour shade RAL 9010 – white
- Al/Cu heat exchanger with low water content, air vent and uniquely shaped lamellas for higher heat output
- the set is packed in durable packaging and contains an installation instructions

Specification

bench element height (mm)	290
width (mm)	260
length (mm)	1 000, 1 200, 1 400, 1 600, 1 800, 2 000
length of bench with desk (mm)	1 060, 1 260, 1 460, 1 660, 1 860, 2 060
heat output (W)	from 1 122 to 2 242
max. working pressure (bar)	12
max. working temperature	110 °C
max. surface temperature	40 °C
connecting thread	inner G 1/2"
connection method	recommended bottom connection, side
design of the covering desk	stone imitation (Terrazzo); wood – beech, oak

Version KORALINE LD Exclusive • steel sheathing, coated in colour shade RAL 9010 – white

Version KORALINE LD InPool (LD InPool) • steel sheathing, stainless steel AISI 316 coated in colour shade RAL 9010 – white, suitable for humid environment



Selectable specification

- set for the bottom connection comprising the thermostatic valve and the thermostatic head Danfoss including an extension piece, see page 33
- covering desk – Terrazzo stone imitation, beech, oak wood
- if more than 5 pieces are ordered, another colour shade may be ordered according to the RAL scale (the change must be consulted with the manufacturer)
- stainless steel design suitable for humid environments such as swimming pools, for which the radiator is made of stainless steel AISI 316 and coated in colour shade RAL 9010
- in pool areas the bench must be fitted with stone desk (Terrazzo)

Elements' sections

Side connection

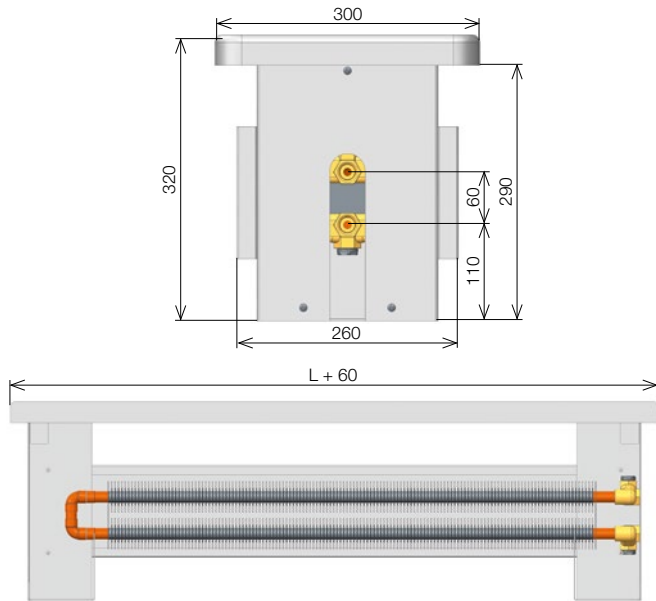

Bottom connection

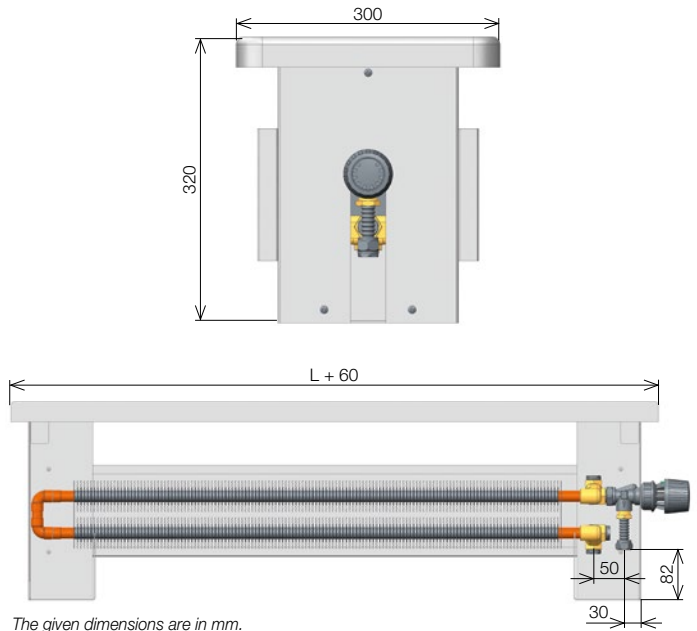

The given dimensions are in mm.

Heat outputs

Heat output (W) at $t_1/t_2/t_i = 75/65/20\text{ }^\circ\text{C}$ (t50) and $65/55/20\text{ }^\circ\text{C}$ (t40)/EN 442

Height (cm)	Width (cm)	Δt	Length L (cm)					
			100	120	140	160	180	200
29	26	Δt 50	1122	1346	1570	1794	2018	2242
		Δt 40	828	993	1159	1324	1489	1655

* the indicated height and width are without the covering desk

Correction factor k_t for a variant temperature difference Δt (K)

Δt (K)	18	19	20	21	22	23	24	25	26	27	28	29	30	31	32	33
k_t	0.248	0.267	0.287	0.306	0.326	0.347	0.367	0.389	0.410	0.432	0.453	0.476	0.498	0.521	0.544	0.567
Δt (K)	34	35	36	37	38	39	40	41	42	43	44	45	46	47	48	49
k_t	0.591	0.615	0.639	0.663	0.688	0.713	0.738	0.763	0.788	0.814	0.840	0.866	0.892	0.919	0.946	0.973
Δt (K)	50	51	52	53	54	55	56	57	58	59	60					
k_t	1.000	1.027	1.055	1.083	1.111	1.139	1.167	1.196	1.224	1.253	1.282					

• temperature exponent $m = 1.364$

See the formula and example of conversion to a variant temperature difference on page 93.

Weights and volumes of water of the heating benches and desks

Sheathing

Type	100
kg/linear meter	11.9
l/1 linear meter	1.6

Desk

Type	Terrazzo	wood
kg/linear meter	27	8

The listed weights are without a packaging.

Cover desk design versions



terrazzo

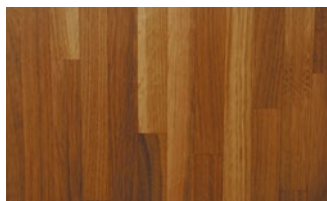

oak



beech

Caution: There is a rule for Terrazzo desk that for the dimensions of KORALINE LD benches of 140, 160, 180 and 200 cm two shorter desks per bench are used for reasons of weight and dimensions. The desks are made of natural materials and therefore minor deviations in the colour design cannot be eliminated. The supplier cannot fully guarantee the presented colours and accept claims due to possible colour deviations. The desks are blocked against movement.

Heat benches installation KORALINE with desk

Installation practice

We recommend to fix the element to the floor using a fastening anchor that is inside the side desk (leg). Once positioned on the convector the desks are fixed on sides against unwanted movement. You will find more detailed information in the installation instructions. The elements are supplied assembled.

KORALINE InPool

Convectors intended for use at pools must be kept clean and regularly washed with clean water. It is also necessary to fit the pool area benches with stone desks (Terrazzo) only.

Elements connection set content Kv values for the Danfoss RA-N 15 UK 1/2" valve

RA-N 15 valve

- thermostatic valve
- Danfoss RA-N 15 1/2" (Specially adjusted for free standing convectors)
- valve body allowing presetting of flow
- flow can be set without using tools
- basic setting is selectable in 7 stages
- maximum working pressure 10 bar
- maximum working temperature 120 °C
- threadless connection with the thermostatic head



Thermostatic head

- thermostatic gas-steam head
- Danfoss RA 2980
- the fastest response time
- anti-theft lock
- temperature setting limiting/blocking pins



Extension piece

- used for height compensation between the input and output of the heat exchanger screw union
- stainless-steel design
- connection thread G 1/2" inner
- straight piece for two-row exchangers



Preset stage	1	2	3	4	5	6	7	N
Kv	0.16	0.20	0.25	0.36	0.47	0.59	0.74	0.81

Note: The connecting set elements are packed as a complete set and cannot be supplied separately.

Ordering codes Heat benches KORALINE LD with desk

		Length (cm)	Height (cm)	Width (cm)	Colour
Exclusive	white steel/unpainted exchanger	LDX ...	29	26	- 10
InPool	stainless steel* white/unpainted exchanger**	LDP ...	29	26	- 10

* humid environment stainless steel AISI 316
** custom-made design

Heat benches
KORALINE LD with desk

ORDERING CODE: heat bench KORALINE length (cm).
Example: LDX1602926-10 = heat bench KORALINE with desk, length 160 cm.

The desk must be ordered separately! The standard version enables side or bottom connection to the heating system; there is no need to specify this in the order.



[KORAWALL

WALL MOUNTED CONVECTORS natural convection

Apart from their design the wall mounted convectors also offer many other advantages: efficient operation, higher performance with smaller dimensions, faster onset of heat. You won't burn yourself with our convectors! Surface max. temperature is 40 °C and the heat is transferred to the space of the room, and not into the wall. PLAN – design solution of wall mounted convector with flat front panel.



Wall mounted convectors with natural convection KORAWALL

The wall mounted convectors KORAWALL are standard wall mounted convectors with a long history, used in households as well as in commercial premises. The modern design, easy mounting and economical operation are the reasons why they are so popular with our customers. With regard to the unique design of the heat exchanger used they achieve higher outputs even with small dimensions of the element. The great advantage of the wall mounted convectors KORAWALL is their very low surface temperature of 40 °C and no heat dissipation into the wall.

Wall mounted convectors' classification

- KORAWALL WK Economic
- KORAWALL WP – element with flat front panel
- KORAWALL WK and WP InPool – element intended for humid environment

Standard delivery contains

- sheathing of zinc galvanised steel sheathing coated in shade RAL 9010 – white
- Al/Cu heat exchanger with low water content, air vent and uniquely shaped lamellas for a higher heat output
- version with the bottom or side connection (according to the code in the order)
- set for suspension of the element on the wall containing dowels, screws and suspension brackets
- the set is packed in durable packaging and contains an installation instructions

Specification

height (mm)	450, 600
depth (mm)	60, 120
length (mm)	400, 600, 800, 1 000, 1 200, 1 400, 1 600, 1 800, 2 000
heat output (W)	from 266 to 2 598
max. working pressure (bar)	12
max. working temperature	110 °C
max. surface temperature	40 °C
connecting thread	inner G 1/2"
connection method	recommended bottom connection, side

Version WK (Economic) and WP (Plan) • sheathing of zinc galvanised steel sheet coated in shade RAL 9010

Version InPool • sheathing made of stainless steel AISI 316 and coated with RAL 9010 colour; intended for humid environment

Selectable specification

- in case of ordering more than 5 pieces it is possible to choose another colour shade finish according to the RAL scale (the manufacturer must be consulted about the change)
- all-stainless steel design suitable for humid environments such as swimming pools, stainless steel AISI 316 coated in white colour shade RAL 9010
- in case of low temperature gradient or lack of performance unit with a fan can be used, see page 78

Design version KORAWALL PLAN

PLAN with an absolutely flat front panel.



Elements' sections

Side connection

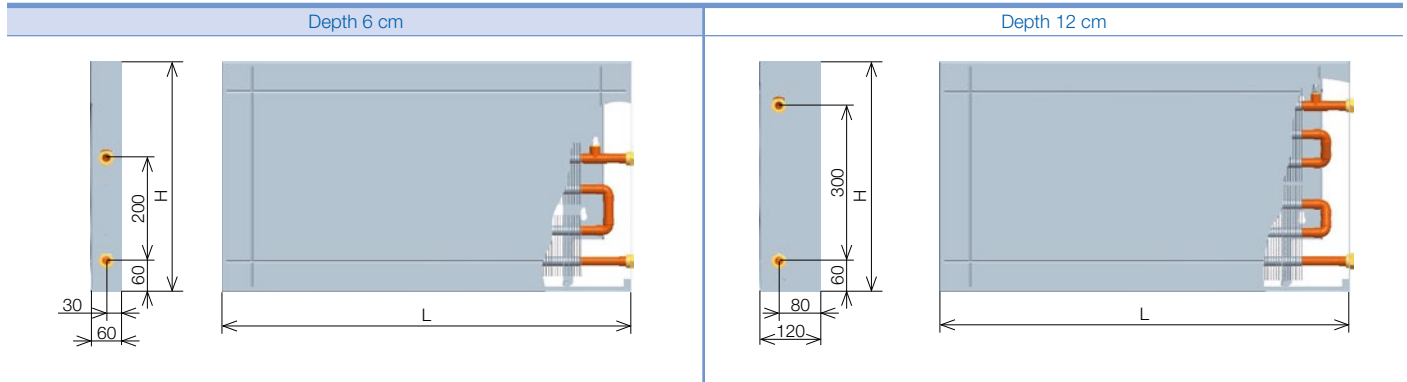

Bottom connection

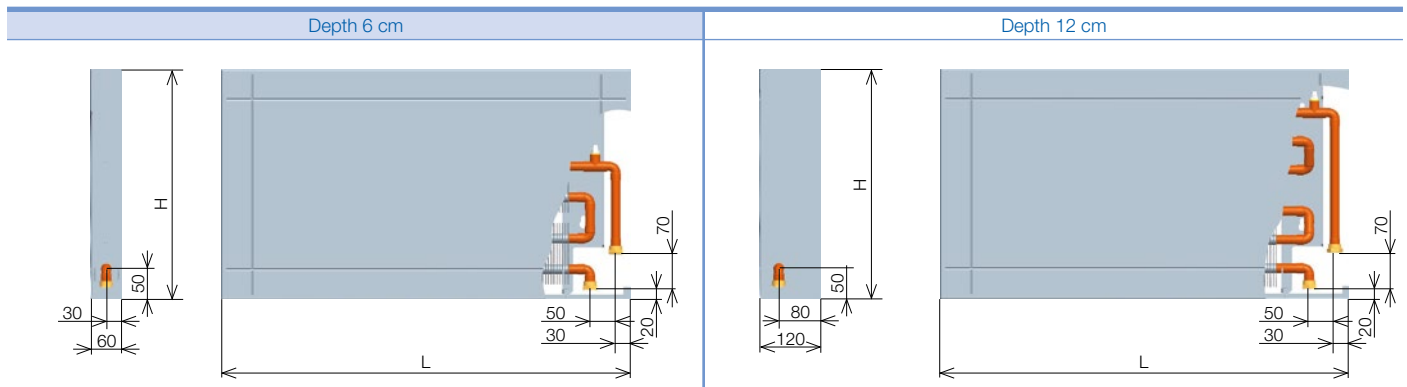

KORAWALL is available in right or left version. The connecting side must be indicated in the order. In the schematic representations the dimensions are expressed in mm.

Heat outputs

Heat outputs (W) at $t_1/t_2/t_i = 75/65/20\text{ }^\circ\text{C}$ ($\Delta t=50$) and $65/55/20\text{ }^\circ\text{C}$ ($\Delta t=40$)/EN 442

Depth (cm)	Δt	Length L (cm)									
		40	60	80	100	120	140	160	180	200	
Height 45	6	$\Delta t 50$	266	400	533	665	799	933	1065	1199	1332
		$\Delta t 40$	199	299	399	498	598	698	797	897	997
	12	$\Delta t 50$	449	675	902	1127	1354	1578	1804	2030	2258
		$\Delta t 40$	336	505	675	843	1013	1181	1350	1519	1690
Height 60	6	$\Delta t 50$	291	436	582	727	873	1018	1159	1304	1450
		$\Delta t 40$	218	327	435	544	653	762	867	976	1085
	12	$\Delta t 50$	519	779	1039	1298	1558	1818	2078	2338	2598
		$\Delta t 40$	388	583	777	972	1166	1360	1555	1749	1944

• temperature exponent $m = 1.3$



Design solutions

The wall mounted heat elements KORAWALL WK and KORAWALL WK InPool have on their front face a significant design element which consists of one design section in the lengths from 40 to 120 cm, two sections in the lengths from 140 to 180 cm and three sections in the length of 200 cm.

Correction factor kt for a variant temperature difference Δt (K)



Δt (K)	18	19	20	21	22	23	24	25	26	27	28	29	30	31	32	33
kt	0.265	0.284	0.304	0.324	0.344	0.364	0.385	0.406	0.427	0.449	0.471	0.493	0.515	0.537	0.560	0.583
Δt (K)	34	35	36	37	38	39	40	41	42	43	44	45	46	47	48	49
kt	0.606	0.629	0.652	0.676	0.700	0.724	0.748	0.773	0.797	0.822	0.847	0.872	0.897	0.923	0.948	0.974
Δt (K)	50	51	52	53	54	55	56	57	58	59	60					
kt	1.000	1.026	1.052	1.079	1.105	1.132	1.159	1.186	1.213	1.240	1.267					

• temperature exponent $m = 1.3$

See the formula and example of conversion to a variant temperature difference on page 93.

Weights and water volumes of wall mounted convectors

KORAWALL WK (WP) InPool version

Convectors intended for use at pools must be kept clean and regularly washed with clean water.

Type	45/6	60/6	45/12	60/12
kg/linear meter	14.9	19	16.4	20.6
stainless steel kg/1 linear meter	11.5	14.5	13	16
l/1 linear meter	1	1.5	1	1.5

The listed weights are without a packaging.

Installation of convectors KORAWALL

Installation instructions

It is recommended to always position the wall mounted heating element on a peripheral wall, 10 cm above the floor. Elements are suspended on the wall with the use of dowels and screws included in the packaging. See the sketch of element anchorage for the method of suspension on the wall. The elements are supplied assembled. Detailed information about installation and fixing the units KORAWALL can be found in Assembly Instructions.

Anchoring diagram

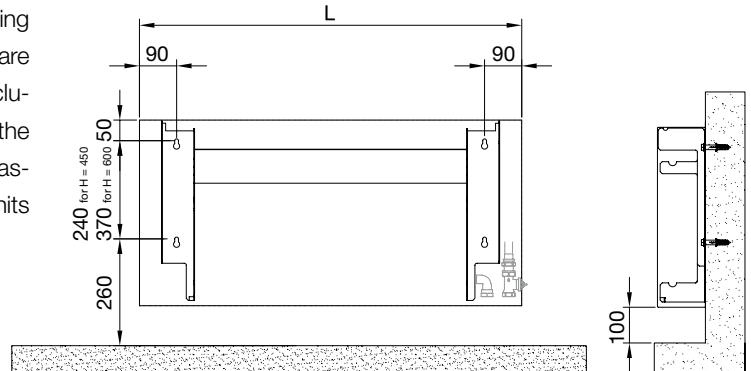

Ordering codes Wall mounted convectors KORAWALL

	Sheathing finish K Classical P PLAN*	W	K	E	-	SP	10
Economic	steel/unpainted exchanger	W	K	E	-	SP	10
InPool*	stainless steel for humid environment white/unpainted exchanger	W	K	P	-	SP	10

* custom-made design

Wall mounted convectors
KORAWALL

Type
E Economic
P InPool

Water inlet
SP bottom, right
SL bottom, left
BP side, right
BL side, left

ORDERING CODE: KORAWALL length/height/depth (in cm) connection (B – side, S – bottom) connection side (L – left, P – right) PLAN version (PLAN). Example: WPE1406006-SP10 = convector element KORAWALL, length 140 cm, height 60 cm, depth 6 cm, bottom connection on the right side version – PLAN.



[KORASPACE

FACADE CONVECTORS (natural convection)

Facade convectors are ideal and effective solution for installations in buildings with large glass walls where the transmission of cold in winter season considerably affects the interior microclimate. Novelty in the heat loss solution will enable the architects and designers to realize their ideas in the design and operation of the entire building, including heating.

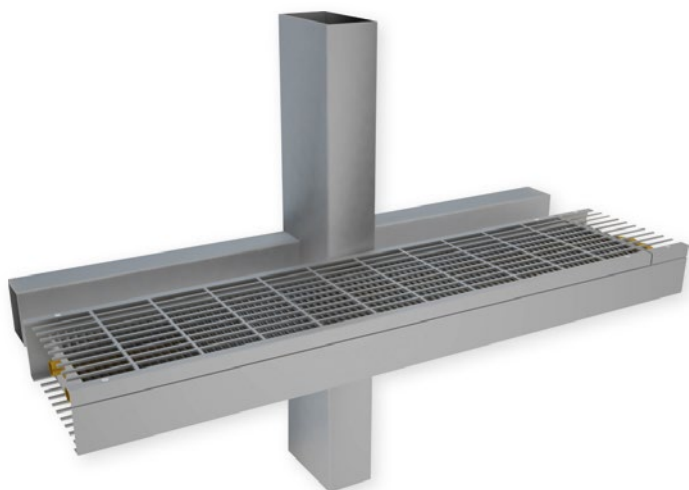

Facade convectors with natural convection KORASPACE

The facade convectors KORASPACE by their direct location on the facade prevent penetration of the cold air into the interior space. The warm air rising from the convectors mixes with the cold air and creates a thermal screen which provides greater thermal comfort of the indoor space and prevents condensation forming on the glass surface.

- design freedom
- high-performance Al/Cu heat exchangers
- excellent controllability and fast heating start-up
- without heat transfer to the external facade
- additional space for placement of other through-running distribution

Standard delivery contains

- sheathing of RAL 9007 coated zinc galvanised steel
- heat exchanger with low water content and uniquely shaped lamellas, air vent
- connecting material
- the set is packed in durable packaging and contains an installation instructions

Specification

depth (mm)	56
width (mm)	120, 150, 180
length (mm)	800 up to 3 000 (at 200 mm steps)
max. working pressure (bar)	12
max. working temperature	110 °C
connecting thread	inner G 1/2"

Version KORASPACE Economic • grey coated sheathing (RAL 9007) and unpainted exchanger

Version KORASPACE Exclusive • grey coated sheathing (RAL 9007) and coated exchanger (RAL 9007)

Version KORASPACE InPool • sheathing of the stainless steel AISI 316 and unpainted exchanger

Selectable specification

- version Exclusive or InPool (using stainless steel AISI 316)
- coated heat exchanger
- if more than 5 pieces are ordered, another colour shade may be ordered according to the RAL scale (the change must be consulted with the manufacturer)
- possibility to order thermoelectric drive or thermostatic valve head and shut-off valves



Elements' sections

Overview of manufactured types

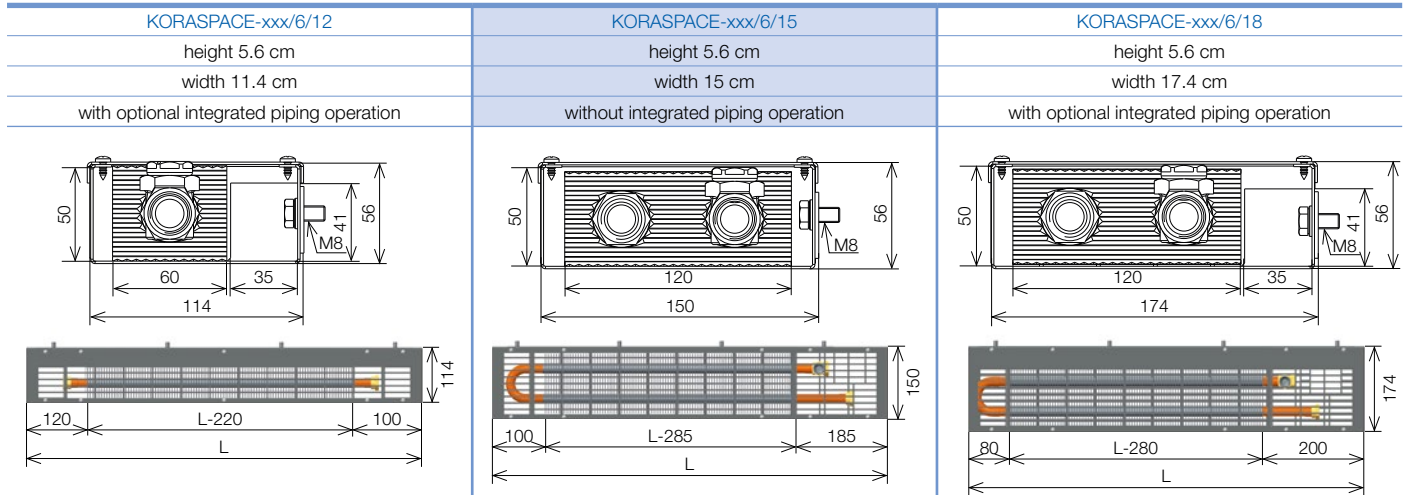

Heat outputs

Heat outputs (W) at $t_1/t_2/t_i = \text{at } 75/65/20 \text{ } ^\circ\text{C}$ ($\Delta t=50$) and $65/55/20 \text{ } ^\circ\text{C}$ ($\Delta t=40$)/EN 442

Height (cm)	Width (cm)	Δt	Length L (cm)											
			80	100	120	140	160	180	200	220	240	260	280	300
Height 6	12	$\Delta t 50$	154	202	251	300	349	397	446	495	543	592	641	690
		$\Delta t 40$	115	151	188	224	261	297	334	370	407	443	480	516
Height 6	15	$\Delta t 50$	305	401	498	595	692	788	885	982	1078	1175	1272	1369
		$\Delta t 40$	228	300	373	445	517	590	662	735	807	879	952	1024
Height 6	18	$\Delta t 50$	305	401	498	595	692	788	885	982	1078	1175	1272	1369
		$\Delta t 40$	228	300	373	445	517	590	662	735	807	879	952	1024

Heat outputs of the widths of 15 and 18 cm are the same due to using the same exchanger. In addition the width of 18 cm comprises space for piping.

Correction factor k_t for a variant temperature difference Δt (K)

Δt (K)	18	19	20	21	22	23	24	25	26	27	28	29	30	31	32	33
k_t	0.265	0.284	0.304	0.324	0.344	0.364	0.385	0.406	0.427	0.449	0.471	0.493	0.515	0.537	0.560	0.583
Δt (K)	34	35	36	37	38	39	40	41	42	43	44	45	46	47	48	49
k_t	0.606	0.629	0.652	0.676	0.700	0.724	0.748	0.773	0.797	0.822	0.847	0.872	0.897	0.923	0.948	0.974
Δt (K)	50	51	52	53	54	55	56	57	58	59	60					
k_t	1.000	1.026	1.052	1.079	1.105	1.132	1.159	1.186	1.213	1.240	1.267					

• temperature exponent $m = 1.3$

See the formula and example of conversion to a variant temperature difference on page 93.

Weights and water volumes of facade convectors

Type	6/12	6/15	6/18
kg/linear meter	3.9	4.8	5.3
l/1 linear meter	0.2	0.42	0.42

The listed weights are without a packaging.

Facade convectors installation KORASPACE



Installation on horizontal crosspiece, between vertical supports



Installation on vertical support

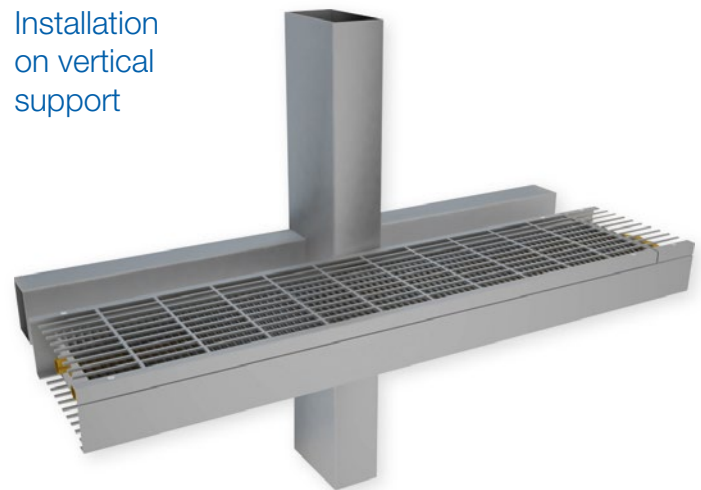

Facade convectors installation technique

Main load bearing U shape part is fixed to the facade's carrying elements. Then the heat exchanger is inserted and connected to the heating system. Last step consists of positioning the top part

and screwing of all parts together. Subject to agreement it is possible to make design modifications for the particular installation.

Convectors KORASPACE assembly

Connections with thermostatic valve and thermoelectric drive

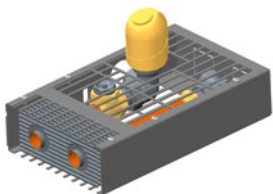

Connections with shut-off valve

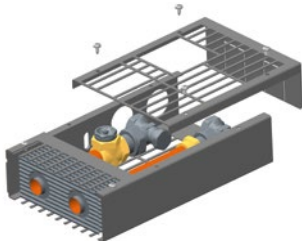

- 1 carrier part
- 2 M8 fastening screw with washer
- 3 air vent
- 4 heat exchanger
- 5 top cover part
- 6 end part
- 7 screw (DIN 7981)

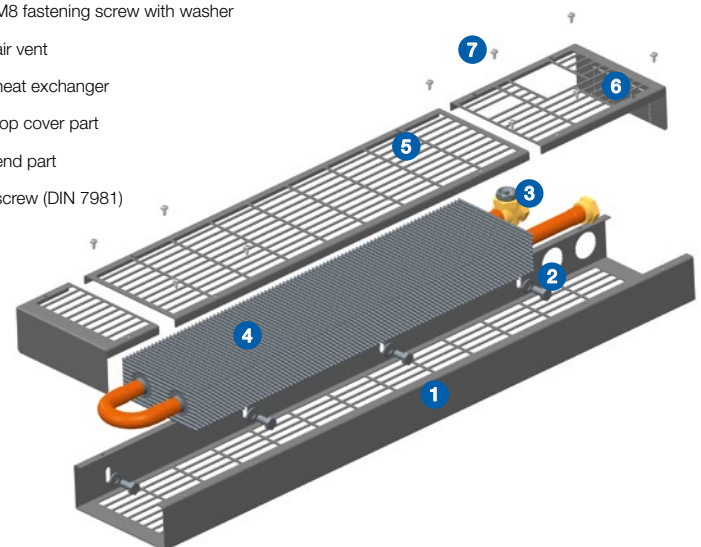

Ordering codes Facade convectors KORASPACE

			Length (cm)	Height (cm)	Width (cm)	On facade installation technique A on horizontal crosspiece, between vertical supports B on vertical support		Colour**
Economic	grey steel/unpainted exchanger	SE	- ...	06	..	-	A	- 10
Exlusive	grey steel/grey coated exchanger	SX	- ...	06	..	-	A	- 10
InPool*	grey coated stainless steel for humid environment/unpainted exchanger	SP	- ...	06	..	-	A	- 10

** standard for the product RAL 9007

Facade convectors
KORASPACE

* custom-made design



[KORABASE

HEAT EXCHANGERS

The heat exchangers KORABASE are the heart of convectors. However, its application is much wider. Imagine that you would like your heating elements to completely blend with the interior. Build your exchangers into materials, the entire interior of which is compactly created, and into places where you want to have them. A real design solution that will fulfil even the most exacting notions of preserving the interior design.

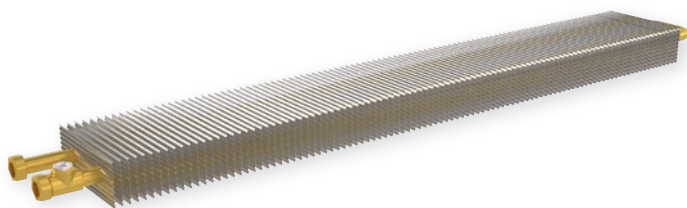

Al/Cu heat exchanger with low water content KORABASE

It is suitable for individual installation, especially in places where compactness of interior is required in terms of materials used. If certain conditions are adhered to, the KORABASE heat exchangers can be covered with almost any material to integrate them unobtrusively into the space. The exchanger is made of copper pipes and aluminium lamellas.

Standard delivery contains

- Al/Cu heat exchanger with low water content, air vent and uniquely shaped lamellas for a higher heat output
- mounting instructions
- the set is packed in strong PVC foil and protectors on edges

Specification

height (mm)	50, 110
width (mm)	60, 120, 180
length (mm)	800 up to 3 000 (at 200 mm steps)
max. working pressure (bar)	12
max. working temperature	110 °C
connecting thread	inner G 1/2"
heat output	according to the exchanger covering height, see the output and correction factors tables for a variant case height

Version KORABASE Economic • exchanger with no surface finish
Version KORABASE Exclusive • black coated exchanger



Selectable specification

- version KORABASE Exclusive
- stands or brackets to fit the exchanger on, see page 45

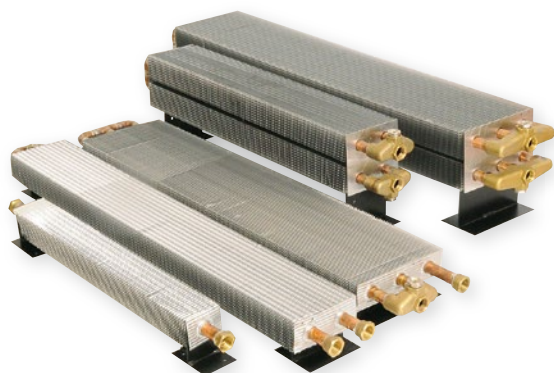

Images are for illustration only.

Elements' sections

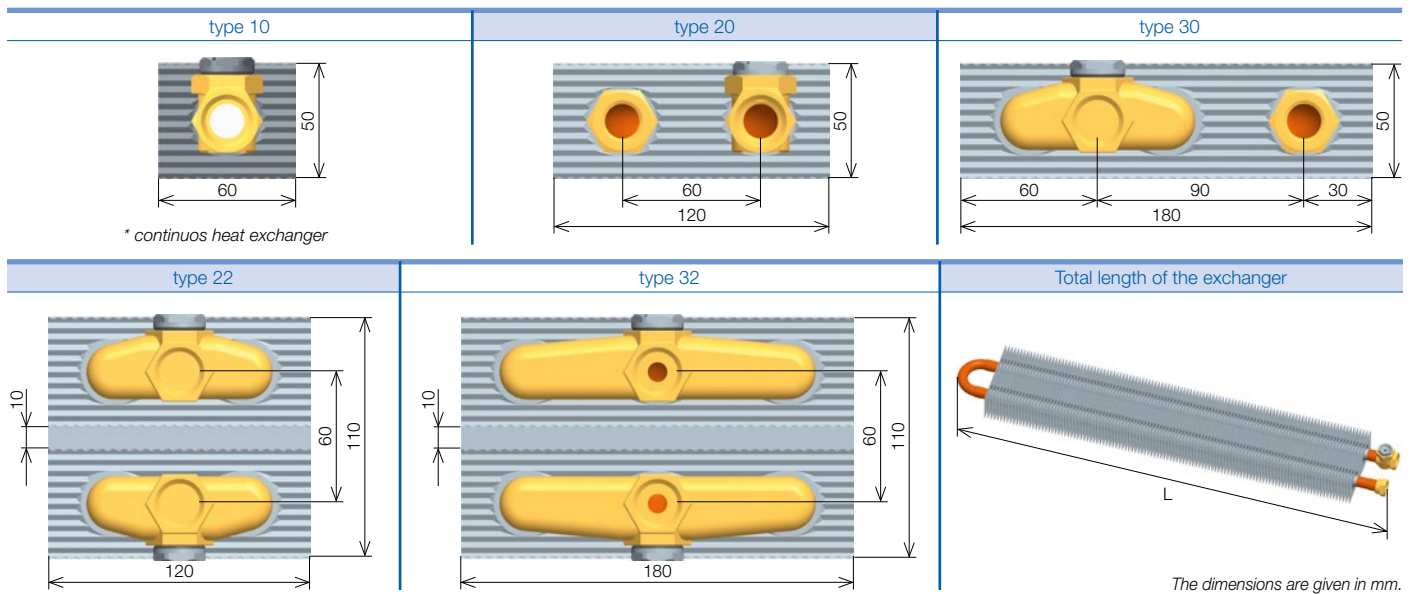

Heat outputs

Heat outputs (W) at $t_1/t_2/t_i = \text{at } 75/65/20 \text{ } ^\circ\text{C}$ ($\Delta t=50$) and $65/55/20 \text{ } ^\circ\text{C}$ ($\Delta t=40$)/EN 442

type KORABASE	Δt	Length L (cm)											
		80	100	120	140	160	180	200	220	240	260	280	300
10	Δt 50	269	344	419	494	568	643	718	793	868	942	1017	1092
	Δt 40	201	257	313	369	425	481	537	593	649	705	761	817
20	Δt 50	542	697	851	1006	1161	1316	1471	1625	1780	1935	2090	2245
	Δt 40	405	521	637	753	869	984	1100	1216	1332	1448	1564	1679
30	Δt 50	685	890	1095	1299	1504	1708	1913	2118	2322	2527	2731	2936
	Δt 40	513	666	819	972	1125	1278	1431	1584	1737	1891	2044	2197
22	Δt 50	636	824	1011	1198	1385	1572	1760	1947	2134	2321	2508	2696
	Δt 40	476	616	756	896	1036	1177	1317	1457	1597	1737	1877	2017
32	Δt 50	948	1227	1506	1784	2063	2342	2621	2900	3178	3457	3736	4015
	Δt 40	709	918	1126	1335	1544	1752	1961	2169	2378	2587	2795	3004

The stated heat outputs apply to the height of 10 cm above the floor and the cover height of 20 cm from the bottom edge of the lamellas.

Correction factor k_t for a variant temperature difference Δt (K)

Δt (K)	18	19	20	21	22	23	24	25	26	27	28	29	30	31	32	33
k_t	0.265	0.284	0.304	0.324	0.344	0.364	0.385	0.406	0.427	0.449	0.471	0.493	0.515	0.537	0.560	0.583
Δt (K)	34	35	36	37	38	39	40	41	42	43	44	45	46	47	48	49
k_t	0.606	0.629	0.652	0.676	0.700	0.724	0.748	0.773	0.797	0.822	0.847	0.872	0.897	0.923	0.948	0.974
Δt (K)	50	51	52	53	54	55	56	57	58	59	60					
k_t	1.000	1.026	1.052	1.079	1.105	1.132	1.159	1.186	1.213	1.240	1.267					

• temperature exponent $m = 1.3$

See the formula and example of conversion to a variant temperature difference on page 93.

Weights and volumes of water of the heating exchangers

Type	10	20	30	22	32
kg/linear meter	0.74	1.47	2.23	3.04	4.56
l/1 linear meter	0.22	0.5	0.75	1	1.6

The listed weights are without a packaging.



Installation instructions

For proper functioning ensure sufficient supply of air, adequately sealed convector case and the outlet grid must vent adequately (see fig. on page 18). We recommend the exchangers are installed 10 cm above the floor covering. We supply 2 types of brackets for

this purpose. These could be of the floor mounting design (stand type) of 7.5 and 12.5 cm height, or of the wall-suspension design. The number of the exchanger's pipes determines the width of the bracket, see below. The brackets are not part of the supply.

Mounting location

Floor mounting stands	Floor mounting stands	Floor mounting brackets	Wall mounting brackets
KORABASE 30 and 32 (supplied in black finish as standard)	KORABASE 20 and 22 (supplied in black finish as standard)	KORABASE 10 (supplied in black finish as standard)	KORABASE 10, 20, 22, 30 and 32 (supplied in white finish as standard)

Correct installation

The heat output of the exchanger is dependent on several key conditions: the effective height of the cover, how well the cover (case) seals, the supply of the heated air and the size of the outlet grid's flow area (see fig.). In general, the higher the cover is positioned, the higher the heat output. The case of the convector and the adjacent building structures must be resistant to the rated temperatures of the heat-carrying media.

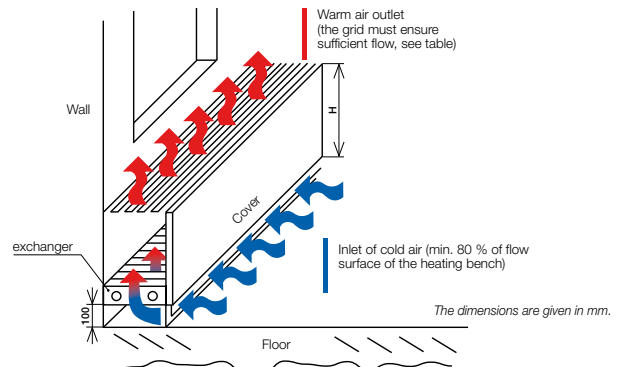

Correction factor for a different case height H Correction factor of the cover grid's flow surface

H (m)	0.200	0.250	0.300	0.350	0.400	0.450	0.500	0.550	0.600
kh	1.000	1.051	1.136	1.207	1.268	1.322	1.371	1.416	1.457

The case height H (m) is taken from the bottom edge of the heat exchanger lamellas. Example: Conversion of the heat output of the KORABASE 30-180 exchanger to the output in a case 0.45 m high. $Q = 1\,708 \times 1.322 = 2\,258\text{ W}$

% of flow surface	> 75	60	50	40	30
correction factor	1.00	0.95	0.90	0.85	0.60

The flow surface means the flow surface of the heat exchanger (width × length of the radiator) minus the area of the cover grid (all dimensions given in %). The heat output of the particular convector is multiplied by this correction factor. Measurements of the performances of products include the cover grid, therefore it is not necessary to further recalculate them.

Ordering codes KORABASE

	Type of connection V reversible P continuous*	Type E Economic X Exclusive	Number of horizontal rows (1,2,3)	Number of vertical rows (0,2)	Length (cm)
Economic unpainted exchanger	B	V	E	- . . -	...
Exclusive* coated exchanger	B	V	X	- . . -	...

* custom-made design

Heat exchangers KORABASE

ORDERING CODE: type/length (cm), example: BVE-30-200 = KORABASE single-row three-pipe heat exchanger, length 200 cm.





Products equipped with forced convection to increase efficiency in heating and cooling





KORAFLEX

FV

Floor convectors
with forced convection

pages 49–57

FI

Floor convectors with forced
convection for heating or cooling

pages 61–64

OPTIMIZED CONVECTION

InPool

Floor convectors
with forced convection InPool

pages 58–60

FW

Floor convectors with forced
convection for heating and cooling

pages 65–67

There are places with higher heat losses. Choose floor convectors KORAFLEX with forced convection and optimized convection in places where the efficiency must be increased while preserving the state of the art design.

- wide use possibilities
- convector increased heat efficiency
- cooling possibility
- very quiet operation
- energy saving fans with electric engine and minimal input

Floor convectors with forced convection

KORAFLEX FV 8/16



OC OPTIMIZED CONVECTION

- the narrowest convector with forced convection
- convector with the low construction height
- used for heating
- quiet operation at low speed
- possibility of control through BMS (Building Management System)
- can be ordered in Economic, Exclusive or Inox versions
- the convector is intended for dry environment

Specifications

width including the U/F type frame (mm)	164U/194F
floor case width (mm)	127
grid width (mm)	152
max. adjustable height (H max. mm)	85–110
case depth (mm)	85
length (L mm)	800 up to 2 800 (at 400 mm steps)
exchanger height (mm)	50
exchanger width (mm)	50
exchanger effective length (mm)	L - 400
fans impeller diameter (mm)	30
connection to the heating system	2x G 1/2" inner
case material	galv. steel, stainless steel AISI 304

Version Economic • black coated zinc galvanised steel case, heat exchanger without any surface finish

Version Exclusive • black coated zinc galvanised steel case, black coated exchanger*

Version Inox • stainless steel unpainted case AISI 304, unpainted exchanger (for dry environment only)*

* custom-made design

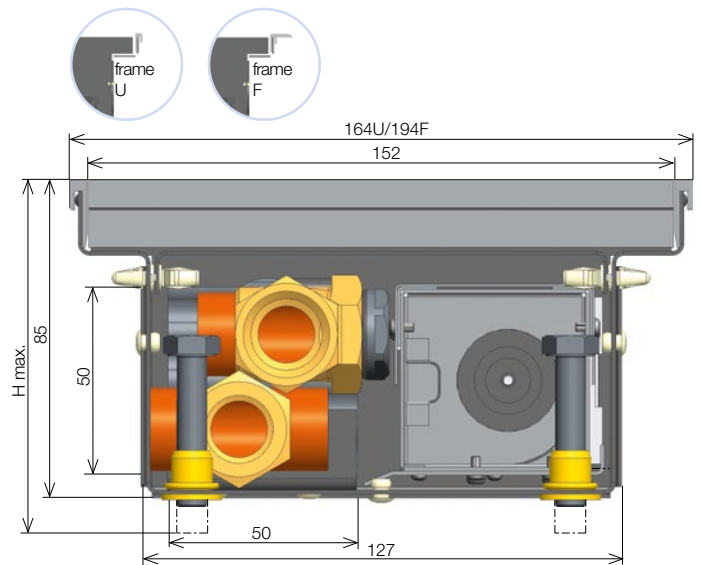

The given dimensions are in mm and with the frames U and F.

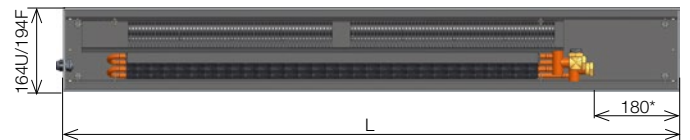

* For all manufactured lengths of KORAFLEX FV 8/16 the average distance for the connection is 180 mm.

* In case of floor convector KORAFLEX FV 8/16 the linear floor grid could not be manufactured as a standard product. Previous consultation is necessary and if possible the convector case is adapted.

Technical parameters



Width	cm	16																							
Depth	cm	8																							
Total length	cm	80				120				160				200				240				280			
Noisiness – acoustic pressure 1m	dB(A)	0	13.2	23	31.1	0	13.4	23.1	31.6	0	13.8	23.7	31.8	0	14.7	26	32,8	0	15	26.5	33	0	15.1	26.7	33.1
Max. input/voltage DC	W/V	3/12–24				5.5/12–24				7.5/12–24				10/12–24				13/12–24				15/12–24			
Speed switch position		Off	1	2	3	Off	1	2	3	Off	1	2	3	Off	1	2	3	Off	1	2	3	Off	1	2	3
Heat output	t1 °C	Heat output [W]/EN 442																							
90/70 °C	20	0	243	303	364	0	498	621	745	0	758	947	1135	0	954	1191	1427	0	1215	1516	1818	0	1469	1834	2199
	18	0	209	261	313	0	428	535	641	0	653	815	977	0	821	1025	1228	0	1045	1305	1564	0	1264	1578	1892
	22	0	192	240	288	0	394	491	589	0	600	749	898	0	755	942	1129	0	961	1199	1438	0	1163	1451	1740
75/65 °C	20	0	201	250	300	0	411	513	615	0	626	782	937	0	788	983	1179	0	1003	1252	1501	0	1213	1515	1816
	18	0	178	222	266	0	364	454	544	0	554	692	829	0	697	870	1043	0	888	1108	1328	0	1074	1340	1607
	22	0	161	201	241	0	329	411	493	0	502	627	751	0	631	788	945	0	804	1003	1203	0	973	1214	1455
70/55 °C	18	0	126	157	188	0	257	321	385	0	392	489	587	0	493	615	738	0	628	784	939	0	759	948	1136
	20	0	117	146	176	0	240	300	360	0	366	457	548	0	461	575	689	0	587	732	878	0	710	886	1062
	22	0	109	136	163	0	224	279	335	0	341	425	510	0	429	535	641	0	546	681	816	0	660	824	988
55/45 °C	18	0	105	131	157	0	215	269	322	0	328	409	491	0	412	515	617	0	525	656	786	0	635	793	951
	20	0	97	121	145	0	198	248	297	0	302	378	453	0	380	475	569	0	484	605	725	0	586	731	877
	22	0	89	111	133	0	182	227	272	0	277	346	415	0	349	435	522	0	444	554	664	0	537	670	803
50/40 °C	18	0	85	106	127	0	174	217	260	0	264	330	396	0	333	415	498	0	424	529	634	0	512	640	767
	20	0	77	96	115	0	157	196	235	0	239	299	358	0	301	376	450	0	383	478	573	0	464	579	694
	22	0	69	86	103	0	141	175	210	0	214	267	321	0	269	336	403	0	343	428	513	0	415	518	621

- temperature exponent m = 1.05

Correction factor page 56 • Assembly page 70 • Regulation page 82 • Floor grids page 18

Floor convectors with forced convection

KORAFLEX FV 8/28



- convector with low construction height
- used for heating
- quietest operation at low speed
- possibility of control through BMS (Building Management System)
- can be ordered in Economic, Exclusive or Inox versions
- the convector is intended for dry environment

Specifications

width including the U/F type frame (mm)	284U/314F
floor case width (mm)	235
grid width (mm)	272
max. adjustable height (H max. mm)	80-107
case depth (mm)	80
length (L mm)	800 up to 2 800 (at 400 mm steps)
exchanger height (mm)	50
exchanger width (mm)	120
exchanger effective length (mm)	L - 350
fans impeller diameter (mm)	30
connection to the heating system	2x G 1/2" inner
case material	galv. steel, stainless steel AISI 304

Version Economic • black coated zinc galvanised steel case, heat exchanger without any surface finish

Version Exclusive • black coated zinc galvanised steel case, black coated exchanger*

Version Inox • stainless steel unpainted case AISI 304, unpainted exchanger (for dry environment only)* * custom-made design

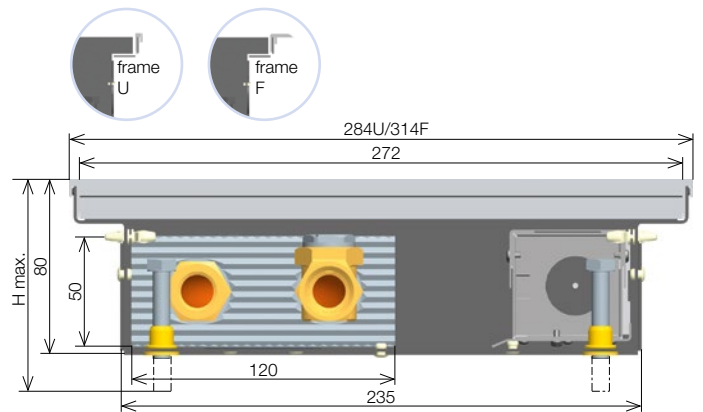

The given dimensions are in mm and with the frames U and F.

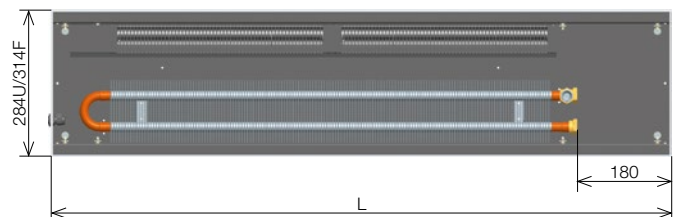

* In case of floor convector KORAFLEX FV 8/28 the linear floor grid could not be manufactured as a standard product. Previous consultation is necessary and if possible the convector case is adapted.

Technical parameters



Width	cm	28																											
Depth	cm	8																											
Total length	cm	80				120				160				200				240				280							
Noisiness - acoustic pressure 1m	dB(A)	0	13.2	23	31.1	0	13.4	23.1	31.6	0	13.8	23.7	31.8	0	14.7	26	32.8	0	15	26.5	33	0	15.1	26.7	33.1				
Power input	W/V	3/12-24				5.5/12-24				7.5/12-24				10/12-24				13/12-24				15/12-24							
Speed switch position		Off	1	2	3	Off	1	2	3	Off	1	2	3	Off	1	2	3	Off	1	2	3	Off	1	2	3	Off	1	2	3
Heat output	t1 °C	Heat output [W]/EN 442																											
90/70 °C	20	169	430	509	737	245	812	962	1392	281	1190	1415	2047	370	1576	1867	2703	436	1958	2320	3358	503	2340	2772	4013				
	18	144	366	434	628	209	692	820	1187	239	1015	1206	1745	316	1343	1591	2304	372	1669	1977	2862	428	1994	2363	3420				
	22	132	335	397	574	191	632	749	1084	219	927	1102	1595	288	1228	1454	2105	340	1525	1807	2616	392	1823	2160	3126				
75/65 °C	20	138	351	415	601	200	662	785	1136	229	971	1154	1670	302	1285	1523	2204	356	1597	1892	2739	410	1909	2261	3273				
	18	120	304	360	521	173	574	680	985	199	842	1001	1448	262	1114	1320	1911	309	1385	1640	2375	355	1655	1961	2838				
	22	108	273	324	469	156	516	612	886	179	757	900	1303	236	1003	1188	1719	278	1246	1476	2136	320	1489	1764	2553				
70/55 °C	18	84	213	253	366	122	403	477	690	139	590	702	1015	184	781	926	1340	216	971	1150	1665	249	1160	1375	1990				
	20	114	289	342	495	165	545	646	935	188	799	950	1374	249	1058	1253	1814	293	1314	1557	2254	337	1571	1861	2694				
	22	108	273	324	469	156	516	612	886	179	757	900	1303	236	1003	1188	1719	278	1246	1476	2136	320	1489	1764	2553				
55/45 °C	18	84	213	253	366	122	403	477	690	139	590	702	1015	184	781	926	1340	216	971	1150	1665	249	1160	1375	1990				
	20	78	198	235	340	113	375	444	643	130	550	653	945	171	728	862	1248	201	904	1071	1550	232	1080	1280	1853				
	22	72	184	218	315	105	347	411	595	120	509	605	875	158	674	798	1155	187	837	991	1435	215	1000	1185	1715				
50/40 °C	18	69	176	209	302	101	333	395	571	115	488	580	840	152	647	766	1109	179	803	952	1378	206	960	1137	1646				
	20	64	162	191	277	92	305	362	524	106	448	532	770	139	593	702	1016	164	736	872	1263	189	880	1042	1509				
	22	58	147	174	253	84	278	330	477	96	408	485	701	127	540	640	926	150	671	795	1150	172	802	950	1375				
45/35 °C	18	55	140	166	240	80	265	314	454	92	388	462	668	121	514	609	882	142	639	757	1096	164	763	905	1309				
	20	50	126	150	216	72	238	282	409	82	350	415	601	109	463	548	794	128	575	681	986	148	687	814	1178				
	22	44	112	133	192	64	212	251	363	73	311	369	534	97	411	487	705	114	511	605	876	131	611	724	1047				

- temperature exponent m = 1.1159

Correction factor page 56 • Assembly page 70 • Regulation page 82 • Floor grids page 18

Floor convectors with forced convection

KORAFLEX FV 9/28



OC OPTIMIZED CONVECTION

- used for heating
- high heat output at a small construction depth
- possibility of control through BMS (Building Management System)
- can be ordered in Economic, Exclusive or Inox versions
- the convector is intended for dry environment

Specifications

width including the U/F type frame (mm)	284U/314F
floor case width (mm)	235
grid width (mm)	272
max. adjustable height (H max. mm)	95-122
case depth (mm)	95
length (L mm)	800 up to 2 800 (at 400 mm steps)
exchanger height (mm)	50
exchanger width (mm)	120
exchanger effective length (mm)	L - 350
fans impeller diameter (mm)	40
connection to the heating system	2x G 1/2" inner
case material	galv. steel, stainless steel AISI 304

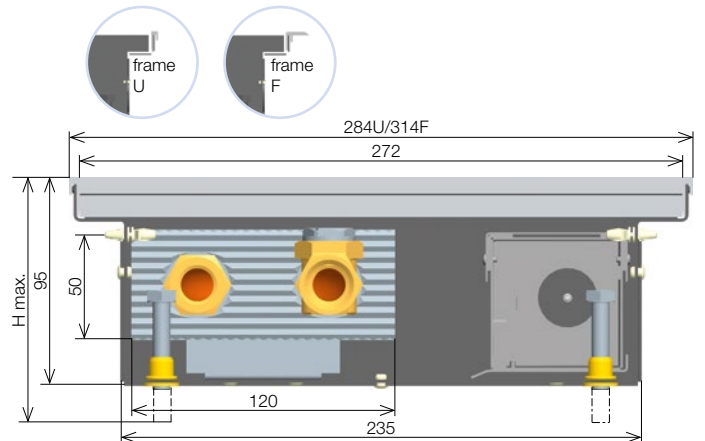

The given dimensions are in mm and with the frames U and F.

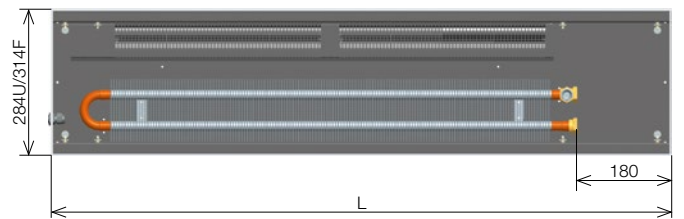

Version Economic • black coated zinc galvanised steel case, heat exchanger without any surface finish

Version Exclusive • black coated zinc galvanised steel case, black coated exchanger*

Version Inox • stainless steel unpainted case AISI 304, unpainted exchanger (for dry environment only)* ** custom-made design*

* In case of floor convector KORAFLEX FV 9/28 the linear floor grid could not be manufactured as a standard product. Previous consultation is necessary and if possible the convector case is adapted.

Technical parameters



Width	cm	28																											
Depth	cm	9																											
Total length	cm	80				120				160				200				240				280							
Noisiness - acoustic pressure 1m	dB(A)	0	16.1	23.6	30.5	0	16.4	21.1	30.9	0	16.7	24.4	31.1	0	17.2	25	31.4	0	17.4	25.1	31.7	0	17.7	25.3	31.7				
Power input	W/V	5.5/12-24				11/12-24				12/12-24				20/12-24				22.5/12-24				23.5/12-24							
Speed switch position		Off	1	2	3	Off	1	2	3	Off	1	2	3	Off	1	2	3	Off	1	2	3	Off	1	2	3				
Heat output	t1 °C	Heat output [W]/EN 442																											
90/70 °C	20	177	570	766	957	257	1077	1447	1807	321	1584	2128	2658	389	2091	2809	3508	457	2598	3490	4359	525	3105	4171	5209				
	18	151	487	654	817	219	920	1236	1544	275	1353	1818	2271	332	1786	2400	2997	390	2219	2981	3724	449	2652	3563	4451				
	22	139	446	599	749	201	843	1132	1414	251	1239	1664	2079	304	1636	2197	2745	358	2032	2730	3410	411	2429	3263	4075				
75/65 °C	20	145	467	627	783	210	881	1184	1479	263	1296	1741	2175	318	1711	2298	2871	374	2126	2856	3567	430	2541	3413	4263				
	18	126	406	545	680	182	766	1029	1285	229	1126	1513	1890	276	1487	1997	2495	325	1847	2482	3100	374	2208	2966	3705				
	22	117	375	504	630	169	709	952	1189	211	1042	1400	1749	256	1376	1848	2308	301	1709	2296	2868	346	2043	2744	3427				
70/55 °C	18	89	286	384	479	129	539	725	905	161	793	1065	1331	195	1047	1407	1757	229	1301	1748	2183	263	1555	2089	2609				
	20	120	385	518	647	173	728	978	1222	217	1070	1438	1797	263	1413	1899	2371	309	1756	2359	2946	355	2099	2819	3521				
	22	117	375	504	630	169	709	952	1189	211	1042	1400	1749	256	1376	1848	2308	301	1709	2296	2868	346	2043	2744	3427				
55/45 °C	18	89	286	384	479	129	539	725	905	161	793	1065	1331	195	1047	1407	1757	229	1301	1748	2183	263	1555	2089	2609				
	20	83	266	357	446	120	502	675	843	150	739	992	1240	181	975	1310	1636	213	1212	1628	2033	245	1448	1945	2430				
	22	77	247	332	414	111	466	626	782	139	686	921	1151	168	905	1216	1519	198	1125	1511	1887	227	1344	1805	2255				
50/40 °C	18	74	237	318	398	107	448	601	751	134	658	884	1105	162	869	1168	1458	190	1080	1451	1812	218	1291	1734	2166				
	20	68	218	293	366	98	412	553	691	123	605	813	1016	149	799	1073	1341	175	993	1334	1666	201	1186	1594	1991				
	22	62	199	267	334	89	375	504	630	112	552	742	927	135	729	979	1223	159	906	1217	1520	183	1082	1454	1816				
45/35 °C	18	59	189	254	317	85	357	480	599	107	525	705	881	129	693	931	1163	151	861	1157	1445	174	1029	1382	1727				
	20	53	170	229	286	77	322	432	540	96	473	635	794	116	625	839	1048	137	776	1042	1302	157	927	1246	1556				
	22	47	152	204	254	68	286	385	481	85	421	566	707	103	556	747	933	122	691	928	1159	140	826	1109	1385				

- temperature exponent m = 1.0996

Correction factor page 56 • Assembly page 70 • Regulation page 82 • Floor grids page 18

Floor convectors with forced convection

KORAFLEX FV 11/20



- used for heating
- high heat output at minimal dimensions
- quiet operation at low speed
- possibility of control through BMS (Building Management System)
- can be ordered in Economic, Exclusive or Inox versions
- the convector is intended for dry environment

Specifications

width including the U/F type frame (mm)	204U/234F
floor case width (mm)	173
grid width (mm)	192
max. adjustable height (H max. mm)	108-132
case depth (mm)	108
length (L mm)	800 up to 2 800 (at 400 mm steps)
exchanger height (mm)	75
exchanger width (mm)	75
exchanger effective length (mm)	L - 400
fans impeller diameter (mm)	40
connection to the heating system	2x G 1/2" inner
case material	galv. steel, stainless steel AISI 304

Version Economic • black coated zinc galvanised steel case, heat exchanger without any surface finish

Version Exclusive • black coated zinc galvanised steel case, black coated exchanger*

Version Inox • stainless steel unpainted case AISI 304, unpainted exchanger (for dry environment only)* * custom-made design

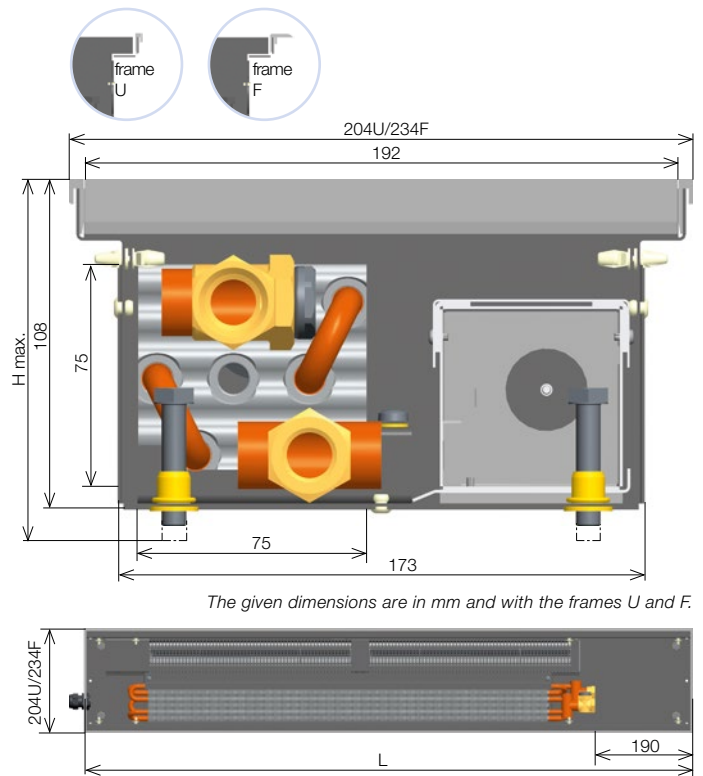

The given dimensions are in mm and with the frames U and F.

* In case of floor convector KORAFLEX FV 11/20 the linear floor grid could not be manufactured as a standard product. Previous consultation is necessary and if possible the convector case is adapted.

Technical parameters



Width	cm	20																							
Depth	cm	11																							
Total length	cm	80				120				160				200				240				280			
Noisiness - acoustic pressure 1m	dB(A)	0	16.1	23.6	30.5	0	16.4	24.1	30.9	0	16.7	24.4	31.1	0	17.2	25	31.4	0	17.4	25.1	31.7	0	17.7	25.3	31.7
Max. input/voltage DC	W/V	5.5/12-24				11/12-24				12/12-24				20/12-24				22.5/12-24				23.5/12-24			
Speed switch position		Off	1	2	3	Off	1	2	3	Off	1	2	3	Off	1	2	3	Off	1	2	3	Off	1	2	3
Heat output	t1 °C	Heat output [W]/EN 442																							
75/65 °C	18	77	563	724	884	148	1078	1385	1692	220	1605	2061	2518	292	2134	2741	3348	364	2659	3416	4173	436	3185	4091	4997
	20	74	542	696	850	142	1037	1332	1627	211	1544	1983	2422	281	2053	2636	3220	350	2558	3285	4013	419	3063	3934	4806
	22	71	520	668	816	136	996	1279	1562	203	1482	1904	2325	270	1971	2532	3092	336	2456	3155	3853	403	2941	3778	4615
70/55 °C	18	66	483	620	757	126	924	1186	1449	188	1375	1766	2157	250	1828	2348	2868	312	2278	2926	3574	374	2728	3504	4280
	20	63	461	592	723	121	882	1133	1384	180	1313	1687	2060	239	1746	2243	2740	298	2176	2795	3414	357	2606	3347	4089
	22	60	439	564	690	115	841	1080	1320	171	1252	1608	1964	228	1665	2138	2612	284	2074	2665	3255	340	2484	3191	3898
55/45 °C	18	48	348	447	546	91	665	855	1044	136	990	1272	1554	180	1317	1692	2067	225	1641	2108	2575	269	1966	2525	3084
	20	45	326	419	512	85	624	802	979	127	929	1193	1457	169	1235	1587	1938	211	1539	1977	2415	252	1843	2368	2892
	22	42	305	391	478	80	583	749	914	119	867	1114	1361	158	1153	1482	1810	197	1437	1846	2255	236	1721	2211	2701
50/40 °C	18	40	294	377	461	77	562	722	882	115	837	1075	1313	152	1112	1429	1745	190	1386	1781	2175	227	1660	2132	2605
	20	37	272	349	427	71	521	669	817	106	775	995	1216	141	1031	1324	1617	176	1284	1650	2015	211	1538	1975	2413
	22	34	250	322	393	66	479	616	752	98	713	916	1119	130	949	1218	1488	162	1182	1518	1855	194	1416	1818	2221
45/35 °C	18	33	240	308	376	63	459	589	719	93	682	877	1071	124	908	1166	1424	155	1131	1453	1774	185	1354	1740	2125
	20	30	218	280	342	57	417	536	654	85	621	797	974	113	826	1060	1295	141	1029	1321	1614	169	1232	1582	1933
	22	27	196	252	308	51	376	482	589	77	559	718	877	102	743	955	1166	127	926	1190	1454	152	1109	1425	1741

- temperature exponent m = 0.994

Correction factor page 56 • Assembly page 70 • Regulation page 82 • Floor grids page 18

Floor convectors with forced convection

KORAFLEX FV 11/28 (the best selling type)



OC OPTIMIZED CONVECTION

- used for heating
- achieves high heat outputs
- low noise even in max. rpm
- possibility of control through BMS (Building Management System)
- can be ordered in Economic, Exclusive or Inox versions
- the convector is intended for dry environment

Specifications

width including the U/F type frame (mm)	284U/314F
floor case width (mm)	235
grid width (mm)	272
max. adjustable height (H max. mm)	115-142
case depth (mm)	115
length (L mm)	800 up to 2 800 (at 400 mm steps)
exchanger height (mm)	50
exchanger width (mm)	120
exchanger effective length (mm)	L - 350
fans impeller diameter (mm)	40
connection to the heating system	2x G 1/2" inner
case material	galv. steel, stainless steel AISI 304

Version **Economic** • black coated zinc galvanised steel case, heat exchanger without any surface finish

Version **Exclusive** • black coated zinc galvanised steel case, black coated exchanger*

Version **Inox** • stainless steel unpainted case AISI 304, unpainted exchanger (for dry environment only)* * custom-made design

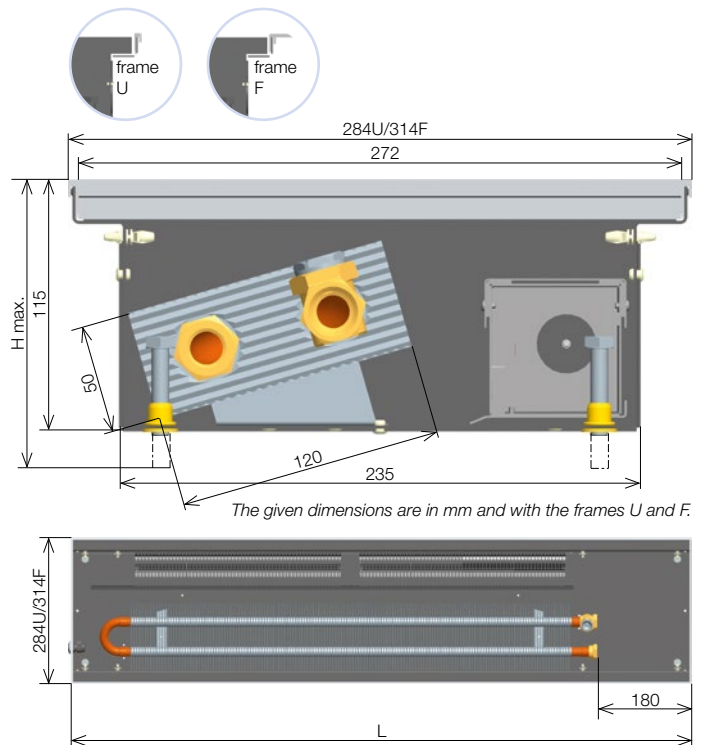

Technical parameters



Width	cm	28																											
Depth	cm	11																											
Total length	cm	80				120				160				200				240				280							
Noisiness - acoustic pressure 1m	dB(A)	0	16.1	23.6	30.5	0	16.4	24.1	30.9	0	16.7	24.4	31.1	0	17.2	25	31.4	0	17.4	25.1	31.7	0	17.7	25.3	31.7				
Power input	W/V	5.5/12-24				11/12-24				12/12-24				20/12-24				22.5/12-24				23.5/12-24							
Speed switch position		Off	1	2	3	Off	1	2	3	Off	1	2	3	Off	1	2	3	Off	1	2	3	Off	1	2	3				
Heat output	t1 °C	Heat output [W]/EN 442																											
90/70 °C	20	203	657	867	1070	364	1241	1638	2020	525	1826	2409	2861	687	2409	3180	3922	848	2994	3951	4872	1009	3578	4721	5823				
	18	173	561	741	914	311	1060	1399	1726	449	1560	2058	2444	587	2059	2717	3350	725	2558	3375	4163	862	3057	4034	4975				
	22	159	514	678	837	285	971	1281	1581	411	1428	1884	2238	537	1885	2488	3068	663	2342	3091	3812	790	2799	3694	4556				
75/65 °C	20	166	538	710	875	298	1016	1340	1653	430	1494	1971	2341	562	1972	2602	3209	694	2450	3233	3987	826	2928	3864	4765				
	18	144	467	617	761	259	883	1165	1437	374	1298	1713	2034	488	1713	2261	2789	603	2129	2809	3465	718	2544	3358	4141				
	22	130	421	555	684	233	794	1048	1293	336	1168	1541	1831	439	1542	2035	2510	543	1916	2528	3118	646	2290	3021	3726				
70/55 °C	18	102	329	434	536	182	622	820	1012	263	914	1206	1433	344	1207	1592	1964	425	1499	1979	2440	506	1792	2365	2916				
	20	137	444	585	722	246	838	1106	1364	355	1233	1626	1931	464	1627	2147	2648	573	2021	2667	3289	681	2415	3188	3931				
	22	130	421	555	684	233	794	1048	1293	336	1168	1541	1831	439	1542	2035	2510	543	1916	2528	3118	646	2290	3021	3726				
55/45 °C	18	84	273	361	445	151	516	681	840	218	759	1001	1189	285	1002	1322	1630	353	1244	1642	2026	420	1487	1963	2421				
	20	95	307	405	499	170	579	764	942	245	852	1123	1334	320	1124	1483	1829	396	1396	1843	2273	471	1669	2202	2716				
	22	88	284	375	462	157	536	708	873	227	789	1041	1236	297	1041	1374	1694	366	1293	1707	2105	436	1546	2040	2516				
50/40 °C	18	84	273	361	445	151	516	681	840	218	759	1001	1189	285	1002	1322	1630	353	1244	1642	2026	420	1487	1963	2421				
	20	78	251	331	409	139	474	626	772	201	698	920	1093	262	921	1215	1499	324	1144	1510	1862	386	1367	1804	2225				
	22	71	229	302	373	127	433	571	704	183	636	840	997	239	840	1108	1367	296	1044	1377	1699	352	1247	1646	2030				
45/35 °C	18	67	218	287	354	121	411	543	670	174	605	798	948	228	799	1054	1300	281	992	1309	1615	335	1186	1565	1930				
	20	61	196	259	319	109	371	489	603	157	545	719	854	205	720	950	1171	253	894	1180	1455	301	1069	1410	1739				
	22	54	175	231	284	97	330	436	537	140	486	641	761	183	641	846	1043	226	796	1051	1296	268	952	1256	1549				

• temperature exponent m = 1.1

Correction factor page 56 • Assembly page 70 • Regulation page 82 • Floor grids page 18

Floor convectors with forced convection

KORAFLEX FV 11/34



- used for heating
- high performance convector at optimal width
- quietest operation at low speed
- possibility of control through BMS (Building Management System)
- can be ordered in Economic, Exclusive or Inox versions
- the convector is intended for dry environment

Specifications

width including the U/F type frame (mm)	344U/ 374F
floor case width (mm)	295
grid width (mm)	332
max. adjustable height (H max. mm)	115-142
case depth (mm)	115
length (L mm)	800 up to 2 800 (at 400 mm steps)
exchanger height (mm)	50
exchanger width (mm)	180
exchanger effective length (mm)	L - 350
fans impeller diameter (mm)	40
connection to the heating system	2x G 1/2" inner
case material	galv. steel, stainless steel AISI 304

Version Economic • black coated zinc galvanised steel case, heat exchanger without any surface finish

Version Exclusive • black coated zinc galvanised steel case, black coated exchanger*

Version Inox • stainless steel unpainted case AISI 304, unpainted exchanger (for dry environment only)*

* custom-made design

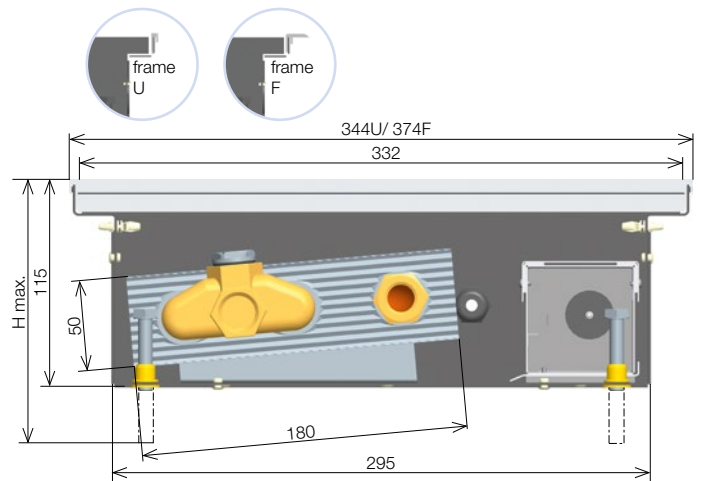

The given dimensions are in mm and with the frames U and F.

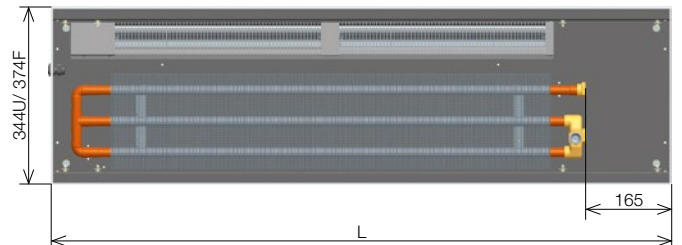

Technical parameters



Width	cm	34																							
Depth	cm	11																							
Total length	cm	80				120				160				200				240				280			
Noisiness - acoustic pressure 1m	dB(A)	0	16.1	23.6	30.5	0	16.4	24.1	30.9	0	16.7	24.4	31.1	0	17.2	25	31.4	0	17.4	25.1	31.7	0	17.7	25.3	31.7
Power input	W/V	5.5/12-24				11/12-24				12/12-24				20/12-24				22.5/12-24				23.5/12-24			
Speed switch position		Off	1	2	3	Off	1	2	3	Off	1	2	3	Off	1	2	3	Off	1	2	3	Off	1	2	3
Heat output	t1 °C	Heat output [W]/EN 442																							
90/70 °C	20	195	873	1119	1364	369	1650	2113	2577	543	2426	3108	3790	716	3202	4102	5002	890	3978	5097	6215	1064	4755	6091	7428
	18	167	746	956	1166	315	1409	1805	2202	464	2073	2655	3238	612	2736	3505	4274	760	3399	4354	5310	909	4062	5204	6346
	22	153	683	875	1067	289	1291	1653	2016	425	1898	2431	2965	560	2505	3209	3914	696	3112	3987	4862	832	3720	4765	5811
75/65 °C	20	160	715	915	1116	302	1350	1729	2109	444	1985	2543	3101	586	2620	3357	4093	728	3255	4171	5086	870	3891	4984	6078
	18	141	629	805	982	266	1187	1521	1855	391	1746	2237	2728	516	2305	2953	3601	641	2864	3669	4474	766	3423	4385	5347
	22	127	567	726	885	239	1071	1371	1672	352	1574	2017	2459	465	2078	2662	3246	578	2582	3308	4033	690	3086	3953	4820
70/55 °C	18	98	437	560	683	185	826	1058	1291	272	1215	1556	1898	359	1604	2055	2505	446	1993	2553	3113	533	2381	3051	3720
	20	134	598	766	934	252	1129	1446	1763	371	1660	2127	2593	490	2191	2807	3423	609	2722	3488	4253	728	3254	4168	5083
	22	127	567	726	885	239	1071	1371	1672	352	1574	2017	2459	465	2078	2662	3246	578	2582	3308	4033	690	3086	3953	4820
55/45 °C	18	98	437	560	683	185	826	1058	1291	272	1215	1556	1898	359	1604	2055	2505	446	1993	2553	3113	533	2381	3051	3720
	20	91	407	522	636	172	770	986	1202	253	1132	1450	1768	334	1494	1914	2334	415	1856	2378	2899	496	2218	2842	3465
	22	84	378	484	590	160	713	914	1114	235	1049	1344	1639	310	1385	1774	2163	385	1720	2204	2688	460	2056	2634	3212
50/40 °C	18	81	363	465	567	153	685	878	1071	225	1008	1291	1574	298	1330	1704	2078	370	1653	2117	2582	442	1975	2531	3086
	20	75	333	427	521	141	630	807	984	207	926	1186	1447	273	1222	1566	1910	340	1519	1946	2373	406	1815	2325	2835
	22	68	304	390	475	129	575	736	898	189	845	1082	1320	249	1115	1429	1742	310	1386	1775	2165	370	1656	2121	2587
45/35 °C	18	65	290	371	452	122	547	701	855	180	805	1031	1257	238	1062	1361	1659	295	1319	1690	2061	353	1577	2020	2464
	20	58	261	334	407	110	493	631	770	162	724	928	1132	214	956	1225	1494	266	1188	1522	1856	318	1420	1819	2218
	22	52	232	298	363	98	439	562	685	144	645	827	1008	190	852	1091	1330	237	1058	1356	1653	283	1265	1620	1976

• temperature exponent m = 1.1

Correction factor page 56 • Assembly page 70 • Regulation page 82 • Floor grids page 18

Floor convectors with forced convection

KORAFLEX FV 11/42



OC OPTIMIZED CONVECTION

- used for heating
- highest heat output
- low noise even in max. rpm
- possibility of control through BMS (Building Management System)
- can be ordered in Economic, Exclusive or Inox versions
- the convector is intended for dry environment

Specifications

width including the U/F type frame (mm)	424U/454F
floor case width (mm)	375
grid width (mm)	412
max. adjustable height (H max. mm)	115-142
case depth (mm)	115
length (L mm)	800 up to 2 800 (at 400 mm steps)
exchanger height (mm)	50
exchanger width (mm)	240
exchanger effective length (mm)	L - 350
fans impeller diameter (mm)	40
connection to the heating system	2x G 1/2" inner
case material	galv. steel, stainless steel AISI 304

Version Economic • black coated zinc galvanised steel case, heat exchanger without any surface finish

Version Exclusive • black coated zinc galvanised steel case, black coated exchanger*

Version Inox • stainless steel unpainted case AISI 304, unpainted exchanger (for dry environment only)*

* custom-made design

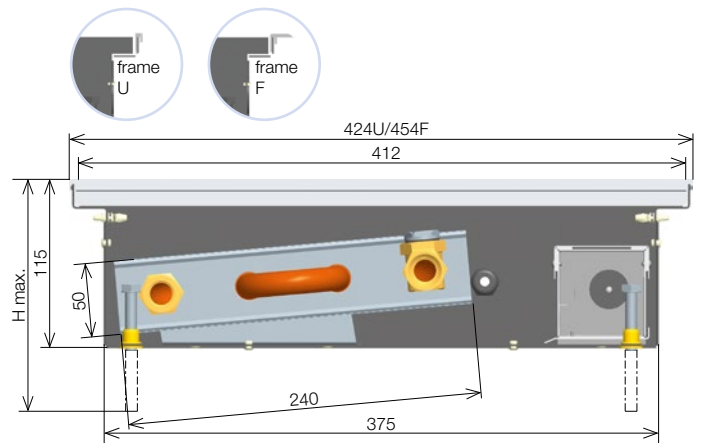

The given dimensions are in mm and with the frames U and F.

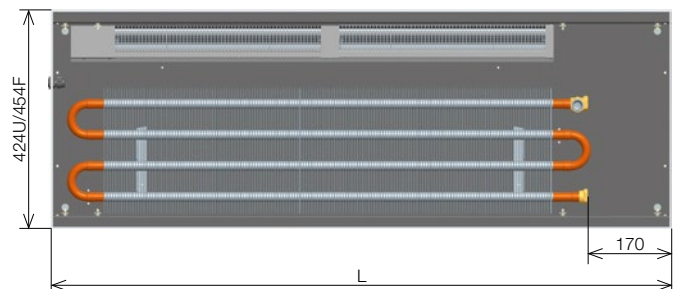

Technical parameters



Width	cm	42																							
Depth	cm	11																							
Total length	cm	80				120				160				200				240				280			
Noisiness - acoustic pressure 1m	dB(A)	0	16.1	23.6	30.5	0	16.4	24.1	30.9	0	16.7	24.4	31.1	0	17.2	25	31.4	0	17.4	25.1	31.7	0	17.7	25.3	31.7
Power input	W/V	5.5/12-24				11/12-24				12/12-24				20/12-24				22.5/12-24				23.5/12-24			
Speed switch position		Off	1	2	3	Off	1	2	3	Off	1	2	3	Off	1	2	3	Off	1	2	3	Off	1	2	3
Heat output	t1 °C	Heat output [W]/EN 442																							
90/70 °C	20	270	1234	1581	1929	509	2331	2987	3643	749	3428	4393	5358	989	4525	5798	7072	1229	5622	7204	8786	1468	6719	8610	10501
	18	230	1054	1351	1648	435	1991	2552	3113	640	2929	3753	4577	845	3866	4954	6042	1050	4803	6155	7507	1254	5740	7356	8971
	22	211	965	1237	1509	399	1824	2337	2850	586	2682	3437	4191	774	3540	4536	5533	961	4398	5636	6874	1149	5256	6736	8215
75/65 °C	20	221	1010	1294	1578	417	1907	2444	2981	613	2805	3595	4384	809	3703	4745	5787	1005	4600	5895	7190	1201	5498	7045	8593
	18	194	888	1138	1388	367	1678	2150	2622	539	2468	3162	3857	712	3257	4174	5091	884	4047	5186	6325	1057	4836	6198	7559
	22	175	801	1026	1252	331	1513	1939	2364	486	2225	2851	3477	642	2937	3763	4590	797	3648	4675	5702	953	4360	5588	6815
70/55 °C	18	135	618	792	966	255	1167	1496	1825	375	1717	2200	2683	495	2266	2904	3542	615	2816	3608	4401	735	3365	4312	5259
	20	126	576	738	900	238	1087	1394	1700	349	1599	2049	2499	461	2111	2705	3299	573	2623	3361	4099	685	3134	4017	4899
	22	117	534	684	834	220	1008	1292	1575	324	1482	1900	2317	428	1957	2507	3058	531	2431	3115	3799	635	2905	3723	4541
55/45 °C	18	112	513	657	801	212	968	1241	1514	311	1424	1825	2226	411	1880	2409	2938	510	2336	2993	3650	610	2791	3577	4363
	20	103	471	604	736	194	890	1140	1391	286	1309	1677	2045	377	1727	2213	2700	469	2146	2750	3354	561	2565	3287	4009
	22	94	430	551	672	177	812	1040	1269	261	1194	1530	1866	344	1576	2020	2463	428	1958	2509	3060	511	2340	2999	3657
45/35 °C	18	89	409	524	640	169	773	991	1208	248	1137	1457	1777	328	1501	1923	2346	407	1865	2389	2914	487	2228	2856	3483
	20	81	369	472	576	152	696	892	1088	224	1024	1312	1600	295	1351	1732	2112	367	1679	2152	2624	439	2007	2571	3136
	22	72	328	421	513	135	620	794	969	199	912	1168	1425	263	1203	1542	1881	327	1495	1916	2337	391	1787	2290	2793

• temperature exponent m = 1.1

Correction factor page 56 • Assembly page 70 • Regulation page 82 • Floor grids page 18

Correction factor k_t for a variant temperature difference Δt (K)

KORAFLEX FV 8/16

Δt (K)	18	19	20	21	22	23	24	25	26	27	28	29	30	31	32	33
k_t	0.342	0.362	0.382	0.402	0.422	0.442	0.463	0.483	0.503	0.524	0.544	0.564	0.585	0.605	0.626	0.646
Δt (K)	34	35	36	37	38	39	40	41	42	43	44	45	46	47	48	49
k_t	0.667	0.688	0.708	0.729	0.750	0.770	0.791	0.812	0.833	0.854	0.874	0.895	0.916	0.937	0.958	0.979
Δt (K)	50	51	52	53	54	55	56	57	58	59	60					
k_t	1.000	1.021	1.042	1.063	1.084	1.105	1.126	1.147	1.169	1.190	1.211					

• temperature exponent $m = 1.05$

KORAFLEX FV 8/28

Δt (K)	18	19	20	21	22	23	24	25	26	27	28	29	30	31	32	33
k_t	0.320	0.340	0.360	0.380	0.400	0.420	0.441	0.461	0.482	0.503	0.524	0.545	0.566	0.587	0.608	0.629
Δt (K)	34	35	36	37	38	39	40	41	42	43	44	45	46	47	48	49
k_t	0.650	0.672	0.693	0.715	0.736	0.758	0.780	0.801	0.823	0.845	0.867	0.889	0.911	0.933	0.955	0.978
Δt (K)	50	51	52	53	54	55	56	57	58	59	60					
k_t	1.000	1.022	1.045	1.067	1.090	1.112	1.135	1.157	1.180	1.203	1.226					

• temperature exponent $m = 1.1159$

KORAFLEX FV 9/28

Δt (K)	18	19	20	21	22	23	24	25	26	27	28	29	30	31	32	33
k_t	0.325	0.345	0.365	0.385	0.405	0.426	0.446	0.467	0.487	0.508	0.529	0.549	0.570	0.591	0.612	0.633
Δt (K)	34	35	36	37	38	39	40	41	42	43	44	45	46	47	48	49
k_t	0.654	0.676	0.697	0.718	0.740	0.761	0.782	0.804	0.826	0.847	0.869	0.891	0.912	0.934	0.956	0.978
Δt (K)	50	51	52	53	54	55	56	57	58	59	60					
k_t	1.000	1.022	1.044	1.066	1.088	1.110	1.133	1.155	1.177	1.200	1.222					

• temperature exponent $m = 1.0996$

KORAFLEX FV 11/20

Δt (K)	18	19	20	21	22	23	24	25	26	27	28	29	30	31	32	33
k_t	0.362	0.382	0.402	0.422	0.442	0.462	0.482	0.502	0.522	0.542	0.562	0.582	0.602	0.622	0.642	0.662
Δt (K)	34	35	36	37	38	39	40	41	42	43	44	45	46	47	48	49
k_t	0.682	0.701	0.721	0.741	0.761	0.781	0.801	0.821	0.841	0.861	0.881	0.901	0.920	0.940	0.960	0.980
Δt (K)	50	51	52	53	54	55	56	57	58	59	60					
k_t	1.000	1.020	1.040	1.060	1.080	1.099	1.119	1.139	1.159	1.179	1.199					

• temperature exponent $m = 0.994$

KORAFLEX FV 11/28, 11/34, 11/42

Δt (K)	18	19	20	21	22	23	24	25	26	27	28	29	30	31	32	33
k_t	0.325	0.345	0.365	0.385	0.405	0.426	0.446	0.467	0.487	0.508	0.528	0.549	0.570	0.591	0.612	0.633
Δt (K)	34	35	36	37	38	39	40	41	42	43	44	45	46	47	48	49
k_t	0.654	0.675	0.697	0.718	0.739	0.761	0.782	0.804	0.825	0.847	0.869	0.891	0.912	0.934	0.956	0.978
Δt (K)	50	51	52	53	54	55	56	57	58	59	60					
k_t	1.000	1.022	1.044	1.066	1.088	1.111	1.133	1.155	1.177	1.200	1.222					

• temperature exponent $m = 1.1$

Weights and water volumes

Type	8/16	8/28	9/28	11/20	11/28	11/34	11/42
kg/1 linear meter	5.38	7.3	8.5	6.53	9	11.2	12
Stainless steel kg/1 linear meter	5.3	7.1	8.3	6.4	9	11	12
l/1 linear meter	0.22	0.4	0.4	0.5	0.4	0.6	0.8

The listed weights are without a packaging.

Ordering codes KORAFLEX FV



			Length (cm)	Depth (cm)	Width (cm)	Case type – water supply location			Convector case's face finish			Frame type			
						P on the right (looking out of room)	N on the left (looking out of room)*		0 without lowering of faces	1 supply side face lowering*	2 face lowering on opposite side of the supply*	3 lowering of both faces*	N not fitted with a frame*	U U profile	F F profile*
Economic	black steel case/unpainted exchanger	FVE	-	N	P	0	R			U	1	
Exclusive*	black steel case/black exchanger	FVX	-	N	P	0	R			U	1	
Inox*	stainless steel case/unpainted exchanger	FVI	-	N	P	0	R			U	1	

* custom-made design

Floor convectors with forced convection KORAFLEX FV

Case with noise-absorbing foil
A Yes*
N No

Grid design
R lateral
L longitudinal*

Frame finish
0 not fitted with a frame*
1 aluminium/silver eloxal coat
2 aluminium/bronze eloxal coat*
3 aluminium/light bronze eloxal coat*

Ordering example

KORAFLEX FV, length 120 cm, depth 11 cm, width 34 cm with a black exchanger and F shape frame, bronze eloxal coat = Exclusive Finish, without Anti-noise foil and with possibility of adding lateral cover grid.

Ordering code – FVX1201134-NP0RF2

If the order does not include the decorative frame specification, the tray and the heat exchanger design, the body will be made of black painted steel sheet and silver colour exchanger, and fitted with silver colour U-shaped frame (Economic version).

Assembly page 70 • Regulation page 82 • Floor grids page 18

Convectors breakdown

- 1 case of the floor convector
- 2 heat exchanger
- 3 fan
- 4 connecting terminal (F Box)
- 5 decorative frame
- 6 walkable grid
- 7 covering metal sheet

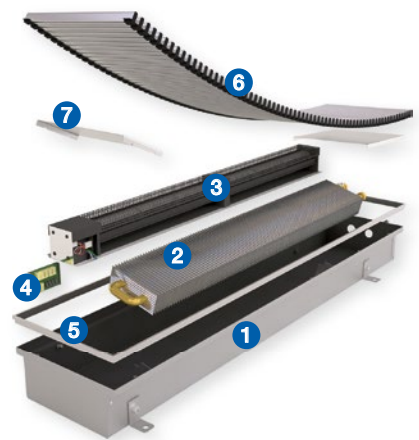

The contents of supplies and selectable specifications

Standard delivery contains

- zinc galvanized steel case, paint finish RAL 9005 – black
- Al/Cu heat exchanger with low water content, air vent and uniquely shaped lamellas for a higher heat output
- group of low-energy fans
- connecting terminal (F Box)
- exchanger temperature switch
- side covering metal sheets in the case colour
- aluminium decor frame, U profile, surface finish silver eloxal coat
- fixing anchors for fastening the convector to the floor
- a set of stainless steel flexible hoses for easy connection to the heating system
- chipboard cover plate protecting the heat exchanger from dust and dirt on building site
- 25 mm height adjustment screws to compensate for the floor unevenness
- the unit is packed in a durable packaging and contains an installation manual

Optional accessories

- stainless steel case finish AISI 304 (Inox) for dry environment
- colour of the anodized Al frame – natural aluminium, light and dark bronze in the F profile or light or dark bronze in the U profile, see sketch page 23
- black coated heat exchanger (Exclusive finish)
- closeable screwing, thermostatic valve and thermostatic head with capillary
- covering plate with increased rigidity
- case with noise-absorbing foil (reduction of noisiness by 1 to 3 dB), see page 90

Note

- standard supply does not include the regulation
- the regulation must be ordered separately in accordance with the technical parameters
- electrical regulation and regulation elements, see page 82
- regulation is identical for all OC convectors

Swimming pool floor convectors with forced convection

KORAFLEX FV 11/34 InPool

- used for heating
- provided with water drain and dividing partition
- high heat output
- low noise even in max. rpm
- possibility of control through BMS (Building Management System)
- special warranty and installation conditions
- recommended to fit with aluminium grid or Stainless steel Cross AISI 316
- supplied only with the InPool design
- the convector is intended for damp environment (i.e. indoor swimming pools, winter gardens)

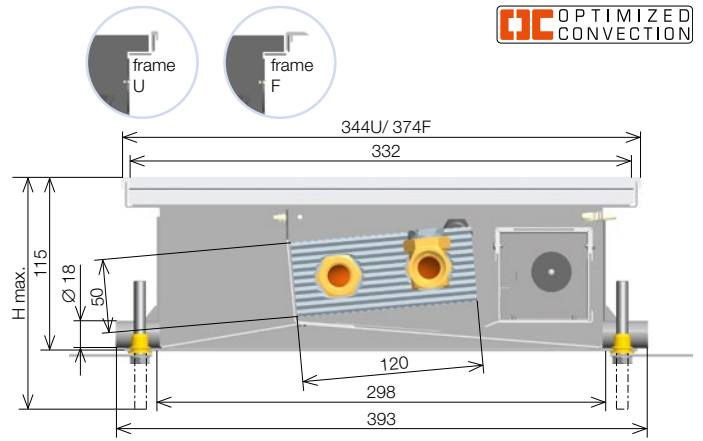

The given dimensions are in mm and with the frames U and F.

Specifications

width including the U/F type frame (mm)	344U/ 374F
floor case width (mm)	298
grid width (mm)	332
max. adjustable height (H max. mm)	123–150
case depth (mm)	115
length (L mm)	800 up to 2 800 (at 400 mm steps)
exchanger height (mm)	50
exchanger width (mm)	120
exchanger effective length (mm)	L - 350
fans impeller diameter (mm)	40
connection to the heating system	2× G 1/2" inner
case material	stainless steel AISI 316

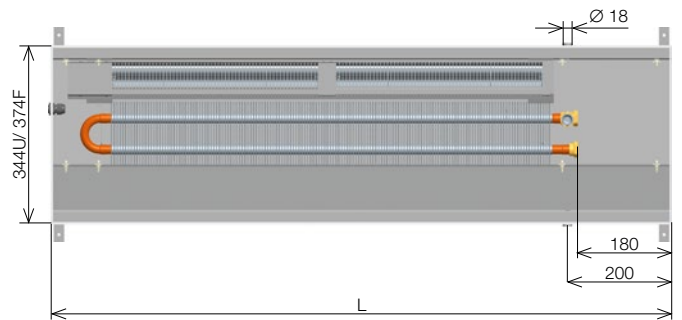

* In case of floor convector KORAFLEX FV 11/34 InPool the linear floor grid could not be manufactured as a standard product. Previous consultation is necessary and if possible the convector case is adapted.

Technical parameters



Width	cm	34																							
Depth	cm	11																							
Total length	cm	80				120				160				200				240				280			
Noisiness – acoustic pressure 1m	dB(A)	0	16.1	23.6	30.5	0	16.4	24.1	30.9	0	16.7	24.4	31.1	0	17.2	25	31.4	0	17.4	25.1	31.7	0	17.7	25.3	31.7
Power input	W/V	5.5/12–24				11/12–24				12/12–24				20/12–24				22.5/12–24				23.5/12–24			
Speed switch position		Off	1	2	3	Off	1	2	3	Off	1	2	3	Off	1	2	3	Off	1	2	3	Off	1	2	3
Heat output	t1 °C	Heat output [W]/EN 442																							
90/70 °C	20	203	657	867	1070	364	1241	1638	2020	525	1643	2168	2575	687	2409	3180	3922	848	2694	3555	4385	1009	2862	3777	4659
	18	173	561	741	914	311	1060	1399	1726	449	1404	1852	2200	587	2059	2717	3350	725	2302	3038	3746	862	2445	3227	3980
	22	159	514	678	837	285	971	1281	1581	411	1285	1696	2014	537	1885	2488	3068	663	2108	2782	3431	790	2239	2955	3644
75/65 °C	20	166	538	710	875	298	1016	1340	1653	430	1345	1774	2107	562	1972	2602	3209	694	2205	2910	3589	826	2342	3091	3812
	18	144	467	617	761	259	883	1165	1437	374	1168	1542	1831	488	1713	2261	2789	603	1916	2528	3118	718	2035	2686	3313
	22	130	421	555	684	233	794	1048	1293	336	1051	1387	1648	439	1542	2035	2510	543	1724	2275	2806	646	1832	2417	2981
70/55 °C	18	102	329	434	536	182	622	820	1012	263	823	1086	1289	344	1207	1592	1964	425	1349	1781	2196	506	1433	1892	2333
	20	137	444	585	722	246	838	1106	1364	355	1109	1463	1738	464	1627	2147	2648	573	1819	2400	2961	681	1932	2550	3145
	22	130	421	555	684	233	794	1048	1293	336	1051	1387	1648	439	1542	2035	2510	543	1724	2275	2806	646	1832	2417	2981
55/45 °C	18	102	329	434	536	182	622	820	1012	263	823	1086	1289	344	1207	1592	1964	425	1349	1781	2196	506	1433	1892	2333
	20	95	307	405	499	170	579	764	942	245	766	1011	1201	320	1124	1483	1829	396	1257	1658	2045	471	1335	1762	2173
	22	88	284	375	462	157	536	708	873	227	710	937	1112	297	1041	1374	1694	366	1164	1536	1895	436	1237	1632	2013
50/40 °C	18	84	273	361	445	151	516	681	840	218	683	901	1070	285	1002	1322	1630	353	1120	1478	1823	420	1190	1570	1937
	20	78	251	331	409	139	474	626	772	201	628	828	984	262	921	1215	1499	324	1030	1359	1676	386	1094	1443	1780
	22	71	229	302	373	127	433	571	704	183	573	756	898	239	840	1108	1367	296	939	1239	1529	352	998	1317	1624
45/35 °C	18	67	218	287	354	121	411	543	670	174	545	718	853	228	799	1054	1300	281	893	1178	1453	335	949	1252	1544
	20	61	196	259	319	109	371	489	603	157	491	647	769	205	720	950	1171	253	805	1062	1310	301	855	1128	1391
	22	54	175	231	284	97	330	436	537	140	437	577	685	183	641	846	1043	226	717	946	1166	268	761	1005	1239

• temperature exponent m = 1.1

Assembly page 70 • Regulation page 82 • Floor grids page 18

Correction factor k_t for a variant temperature difference Δt (K)



KORAFLEX FV 11/34 InPool

Δt (K)	18	19	20	21	22	23	24	25	26	27	28	29	30	31	32	33
k_t	0.325	0.345	0.365	0.385	0.405	0.426	0.446	0.467	0.487	0.508	0.528	0.549	0.570	0.591	0.612	0.633
Δt (K)	34	35	36	37	38	39	40	41	42	43	44	45	46	47	48	49
k_t	0.654	0.675	0.697	0.718	0.739	0.761	0.782	0.804	0.825	0.847	0.869	0.891	0.912	0.934	0.956	0.978
Δt (K)	50	51	52	53	54	55	56	57	58	59	60					
k_t	1.000	1.022	1.044	1.066	1.088	1.111	1.133	1.155	1.177	1.200	1.222					

• temperature exponent $m = 1.1$

Weights and volumes of water and guarantees

Type	11/34
Stainless steel kg/1 linear meter	10.75
l/1 linear meter	0.4

The listed weights are without a packaging.

 **Caution:** Floor convector KORAFLEX FV InPool with forced convection must be positioned so as to prevent even short term flooding of the section fitted with the engine and the fans.

For more information about OPERATION AND GUARANTEE TERMS AND CONDITIONS for CONVECTORS see www.korado.com.

KORAFLEX FV InPool guarantee

Floor convectors including the grid intended for use in the pool area must be kept clean and washed regularly with clean water and maintained with suitable preparations for the preservation of the stainless steel. Convectors are equipped with a drain to prevent their permanent flooding which must be kept clear of any blockage. Floor convectors Koraflex FV InPool cannot be used for pools with salt water. More information can be found in the Operating and warranty terms.

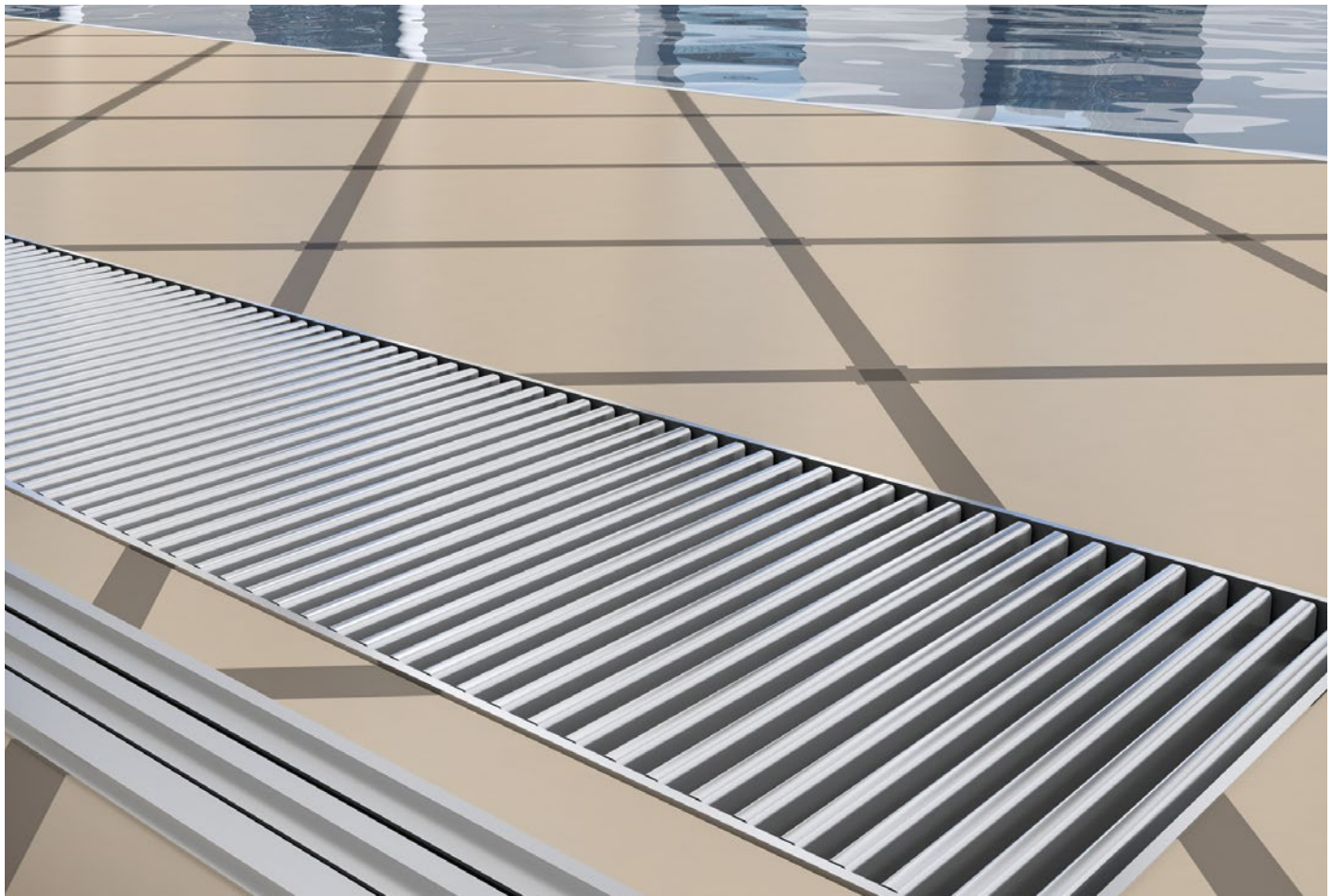

The contents of supplies and selectable specifications

Standard delivery contains

- stainless steel case (stainless steel AISI 316)
- Al/Cu heat exchanger with low water content, air vent and uniquely shaped lamellas for a higher heat output
- separated group of low-energy fans
- drainage holes, including a separation barrier for trapping leaking in water
- connecting terminal (F Box)
- exchanger temperature switch
- side covering metal sheets in the case colour
- anodized Al frame, U profile, in the natural aluminium colour
- a set of stainless-steel elastic hoses for easy connection
- chipboard cover plate protecting the heat exchanger from dust and dirt on building site
- approx. 25 mm height adjustment screws to compensate the uneven floors and an fixing anchor fastening flag for securing the ground
- the unit is packed in a durable packaging and contains an installation manual

Optional accessories

- anodized Al frame, F profile (see sketch)
- colour of the anodized Al frame – natural aluminium, light and dark bronze in the F profile or light or dark bronze in the U profile, see sketch page 23
- closeable screwing, thermostatic valve and thermostatic head with capillary
- cover plate with increased rigidity

Note

- standard supply does not include the regulation
- the regulation must be ordered separately in accordance with the technical parameters
- electrical regulation and regulation elements, see page 82
- regulation is identical for all OC convectors



Caution: Floor convector KORAFLEX FV InPool with forced convection must be positioned so as to prevent even short term flooding of the section fitted with the engine and the fans.

Ordering codes KORAFLEX FV InPool 11/34

InPool*		stainless steel case for moist environment/ unpainted exchanger	FVP	...	Length (cm)	Depth (cm)	Width (cm)	Case type – location of water supply P on the right (looking out of room)		Convector case's face finish 0 without lowering the faces (no other type of case can be used with the FVP model)	Frame type N not fitted with a frame* U U profile F F profile*	
InPool*	stainless steel case for moist environment/ unpainted exchanger	FVP	...	11	34	-	N	P	0	R	U	1
* custom-made design		Floor convectors with forced convection for pools KORAFLEX FV InPool			Case with noise-absorbing foil A Yes* N No			Grid design R lateral L longitudinal* * Only after consultation with the manufacturer		Frame finish 0 not fitted with a frame* 1 aluminium/silver eloxal coat 2 aluminium/bronze eloxal coat* 3 aluminium/light bronze eloxal coat*		

Ordering example

KORAFLEX with forced convection, length 120 cm, depth 11 cm, width 34 cm InPool finish (stainless steel case, heat exchanger without any surface finish) and the F shaped frame, silver eloxal coat = InPool version

Ordering code – FVP1201134-NP0RF1

In the absence of specification in the order the decorative frame will be of the silver frame type in the U shape.



Note: The KORAFLEX FV InPool convector individual cases cannot be mutually interconnected.

Floor convectors with forced convection for heating or cooling KORAFLEX FI 11/20



- used for heating or cooling
- high heating and cooling output
- two-pipe system
- stainless steel design Inox AISI 304 for dry environment only
- the narrowest type of compact dimensions
- possibility of control through BMS (Building Management System)
- standard finish Inox (unpainted stainless steel AISI 304)
- the convector use in for dry environment only

Specifications

width including the U/F type frame (mm)	204U/234F
floor case width (mm)	170
grid width (mm)	192
max. adjustable height (H max. mm)	108-132
case depth (mm)	108
length (L mm)	800 up to 2 800 (at 400 mm steps)
exchanger height (mm)	75
exchanger width (mm)	75
fans impeller diameter (mm)	40
connection to the heating system	2x G 1/2" inner
case material	stainless steel AISI 304

Inox version • stainless steel unpainted case AISI 304, unpainted exchanger (dry environment only), standard design with type 11/20

Technical parameters

Width	cm	20																							
Depth	cm	11																							
Length	cm	80				120				160				200				240				280			
Noisiness - acoustic pressure 1m	dB(A)	0	16.1	23.6	30.5	0	16.4	24.1	30.9	0	16.7	24.4	31.1	0	17.2	25	31.4	0	17.4	25.1	31.7	0	17.7	25.3	31.7
Max. input/voltage DC	W/V	5.5/12-24				11/ 13.5				12/12-24				20/12-24				22.5/12-24				23.5/12-24			
Rpm		Off	1	2	3	Off	1	2	3	Off	1	2	3	Off	1	2	3	Off	1	2	3	Off	1	2	3
Cooling output	t1 °C hum. %	Cooling output [W]																							
6/12 °C	28 50	-	170	241	311	-	326	461	596	-	485	686	887	-	644	912	1180	-	803	1137	1470	-	962	1362	1760
	26 50	-	151	214	276	-	289	409	529	-	430	609	787	-	572	810	1047	-	713	1009	1304	-	853	1208	1562
	24 50	-	132	187	242	-	253	358	462	-	376	532	688	-	500	708	915	-	623	882	1140	-	746	1056	1366
8/14 °C	28 50	-	151	214	276	-	289	409	529	-	430	609	787	-	572	810	1047	-	713	1009	1304	-	853	1208	1562
	26 50	-	132	187	242	-	253	358	462	-	376	532	688	-	500	708	915	-	623	882	1140	-	746	1056	1366
	24 50	-	113	160	207	-	217	307	396	-	322	456	590	-	429	607	784	-	534	756	978	-	640	906	1171
10/15 °C	28 50	-	137	194	251	-	263	372	481	-	391	553	716	-	520	736	951	-	648	917	1186	-	776	1098	1420
	26 50	-	118	168	217	-	227	321	415	-	337	478	617	-	448	635	821	-	559	791	1023	-	669	948	1225
	24 50	-	100	141	182	-	191	270	349	-	284	402	519	-	377	534	690	-	470	665	860	-	563	797	1030
Heat output	t1 °C	Heat output [W]/EN 442																							
75/65 °C	18	77	563	724	884	148	1078	1385	1692	220	1605	2061	2518	292	2134	2741	3348	364	2659	3416	4173	436	3185	4091	4997
	20	74	542	696	850	142	1037	1332	1627	211	1544	1983	2422	281	2053	2636	3220	350	2558	3285	4013	419	3063	3934	4806
	22	71	520	668	816	136	996	1279	1562	203	1482	1904	2325	270	1971	2532	3092	336	2456	3155	3853	403	2941	3778	4615
70/55 °C	18	66	483	620	757	126	924	1186	1449	188	1375	1766	2157	250	1828	2348	2868	312	2278	2926	3574	374	2728	3504	4280
	20	63	461	592	723	121	882	1133	1384	180	1313	1687	2060	239	1746	2243	2740	298	2176	2795	3414	357	2606	3347	4089
	22	60	439	564	690	115	841	1080	1320	171	1252	1608	1964	228	1665	2138	2612	284	2074	2665	3255	340	2484	3191	3898
55/45 °C	18	48	348	447	546	91	665	855	1044	136	990	1272	1554	180	1317	1692	2067	225	1641	2108	2575	269	1966	2525	3084
	20	45	326	419	512	85	624	802	979	127	929	1193	1457	169	1235	1587	1938	211	1539	1977	2415	252	1843	2368	2892
	22	42	305	391	478	80	583	749	914	119	867	1114	1361	158	1153	1482	1810	197	1437	1846	2255	236	1721	2211	2701

- temperature exponent m = 0.994

Listed cooling outputs SENSITIV. Cooling outputs for other operating conditions on request.
 * SENSITIV – cooling power actually delivered for cooling air.
 Correction factor page 63 • Assembly page 70 • Regulation page 82 • Floor grids page 18

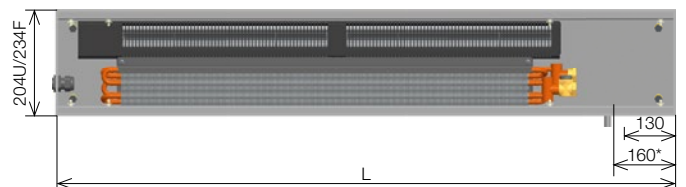
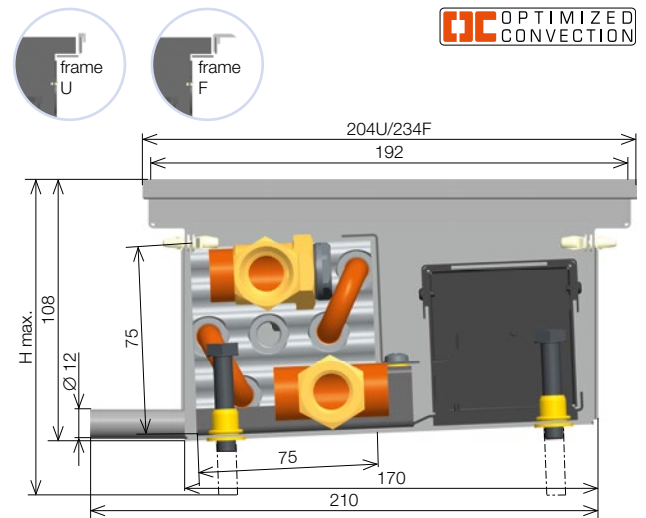

* For all manufactured lengths of KORAFLEX FI 11/20 the average distance for the connection is 160 mm.

* In case of floor convector KORAFLEX FI 11/20 the linear floor grid could not be manufactured as a standard product. Previous consultation is necessary and if possible the convector case is adapted.



Floor convectors with forced convection for heating or cooling

KORAFLEX FI 13/34

- used for heating or cooling
- high heating and cooling output
- two-pipe system
- stainless-steel case for condensate drain
- possibility of control through BMS (Building Management System)
- can be ordered in Economic, Exclusive or Inox versions
- the convector use in for dry environment only

Specifications

width including the U/F type frame (mm)	344U/ 374F
floor case width (mm)	298
grid width (mm)	332
max. adjustable height (H max. mm)	133-160
case depth (mm)	133
length (L mm)	1 200, 1 500, 2 000, 2 500, 3 000
exchanger height (mm)	75
exchanger width (mm)	100
fans impeller diameter (mm)	60
connection to the heating system	2x G 1/2" inner
case material	galv. steel, stainless steel 304, 316

Version Economic • black coated galvanized steel with inner stainless steel case AISI 316, heat exchanger without surface finish

Version Exclusive • black coated zinc galvanised steel case, black coated exchanger*

Version Inox • stainless steel unpainted case AISI 304, unpainted exchanger (for dry environment only)* ** custom-made design*

Technical parameters

Width	cm	34																			
Depth	cm	13																			
Length	cm	120			150			200			250			300							
Noisiness - acoustic pressure 1m	dB(A)	0	28.6	33.1	39.3	0	28.9	33.5	39.8	0	29.3	34	40.4	0	29.6	34.4	40.9	0	29.9	34.8	41.4
Max. input/voltage DC	W/V	9.5/12-24			14/12-24			18.5/12-24			23/12-24			27.5/12-24							
Rpm		Off	1	2	3	Off	1	2	3	Off	1	2	3	Off	1	2	3	Off	1	2	3
Cooling output	t1 °C hum. %	Cooling output [W]																			
6/12 °C	28 50	-	542	772	1003	-	781	1113	1446	-	1179	1681	2183	-	1577	2249	2921	-	1975	2817	3658
	26 50	-	481	685	890	-	693	988	1283	-	1046	1492	1937	-	1399	1995	2591	-	1753	2499	3246
	24 50	-	420	599	778	-	605	863	1121	-	914	1304	1693	-	1223	1744	2265	-	1532	2185	2837
8/14 °C	28 50	-	481	685	890	-	693	988	1283	-	1046	1492	1937	-	1399	1995	2591	-	1753	2499	3246
	26 50	-	420	599	778	-	605	863	1121	-	914	1304	1693	-	1223	1744	2265	-	1532	2185	2837
	24 50	-	360	514	667	-	519	740	961	-	784	1118	1452	-	1049	1495	1942	-	1314	1873	2433
10/15 °C	28 50	-	437	623	809	-	630	898	1166	-	951	1356	1761	-	1272	1814	2356	-	1593	2272	2950
	26 50	-	377	537	698	-	543	775	1006	-	820	1170	1519	-	1098	1565	2032	-	1375	1960	2546
	24 50	-	317	452	587	-	457	651	846	-	690	984	1278	-	923	1316	1709	-	1156	1648	2141
Heat output	t1 °C	Heat output [W]/EN 442																			
75/65 °C	18	239	1794	2320	2847	345	2585	3344	4103	520	3904	5050	6196	696	5222	6756	8289	872	6541	8462	10383
	20	230	1725	2232	2738	331	2486	3216	3946	501	3754	4857	5959	670	5023	6498	7973	839	6291	8138	9986
	22	221	1656	2143	2629	318	2387	3088	3789	481	3605	4664	5722	643	4823	6239	7656	805	6041	7815	9589
70/55 °C	18	205	1536	1987	2439	295	2214	2864	3514	446	3344	4326	5307	596	4473	5787	7101	747	5603	7248	8894
	20	196	1468	1899	2330	282	2115	2736	3357	426	3194	4132	5070	570	4273	5528	6783	714	5353	6924	8496
	22	187	1399	1810	2221	269	2016	2608	3200	406	3045	3939	4833	543	4074	5270	6466	680	5102	6600	8099
55/45 °C	18	148	1107	1432	1757	213	1595	2064	2532	321	2409	3117	3824	430	3223	4170	5116	538	4037	5223	6408
	20	138	1038	1343	1648	199	1496	1936	2375	301	2260	2923	3587	403	3023	3911	4798	505	3786	4898	6010
	22	129	969	1254	1539	186	1397	1807	2217	281	2110	2729	3349	376	2823	3651	4480	471	3535	4573	5612

- temperature exponent m = 0.994

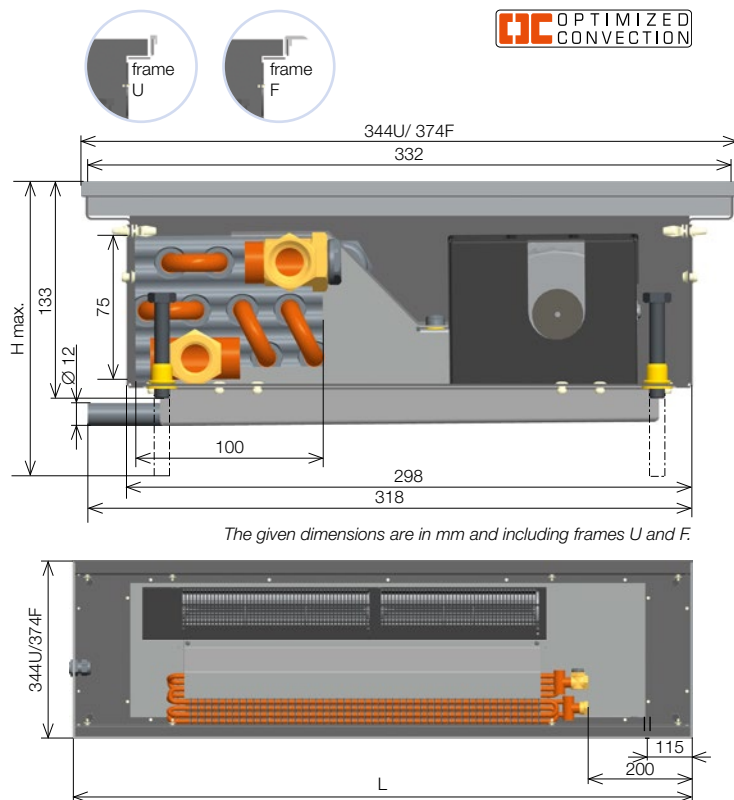

* In case of floor convector KORAFLEX FI 13/34 the linear floor grid could not be manufactured as a standard product. Previous consultation is necessary and if possible the convector case is adapted.



Listed cooling outputs SENSITIV. Cooling outputs for other operating conditions on request.
* SENSITIV - cooling power actually delivered for cooling air.
Correction factor page 63 • Assembly page 70 • Regulation page 82 • Floor grids page 18

Correction factor k_t for a variant temperature difference Δt (K)



KORAFLEX FI 11/20, 13/34

Δt (K)	18	19	20	21	22	23	24	25	26	27	28	29	30	31	32	33
k_t	0.362	0.382	0.402	0.422	0.442	0.462	0.482	0.502	0.522	0.542	0.562	0.582	0.602	0.622	0.642	0.662
Δt (K)	34	35	36	37	38	39	40	41	42	43	44	45	46	47	48	49
k_t	0.682	0.701	0.721	0.741	0.761	0.781	0.801	0.821	0.841	0.861	0.881	0.901	0.920	0.940	0.960	0.980
Δt (K)	50	51	52	53	54	55	56	57	58	59	60					
k_t	1.000	1.020	1.040	1.060	1.080	1.099	1.119	1.139	1.159	1.179	1.199					

• temperature exponent $m = 0.994$

Weights and water volumes

Type	11/20	13/34
steel kg/linear meter	–	13
stainless steel kg/linear meter	7.95	10.9
l/1 linear meter	0.4	0.56

The listed weights are without a packaging.

Delivery content and selectable specifications

Standard delivery contains

- galvanized steel case, surface finish RAL 9005 – black
- inner case (stainless steel AISI 316)
- Al/Cu heat exchanger with low water content and air vent
- set of low-energy fans
- connecting terminal (F Box)
- 2 temperature switches (heating, cooling)
- side cover metal sheets in colour of the case
- anodized Al frame, U profile, in the natural aluminium colour
- fixing anchors for fastening the convector to the floor
- a pair of stainless-steel elastic hoses for easy connection
- chipboard cover plate protecting the heat exchanger from dust and dirt on building site
- 25 mm height adjustment screws to compensate the floor unevenness
- the unit is packed in a durable packaging and with an installation manual

Optional accessories for complete finish

- version Exclusive or Inox
- colour of the anodized Al frame – natural aluminium, light and dark bronze for F profile or light or dark bronze in the U profile, see sketch page 23
- closeable screwing, thermostatic valve and thermostatic head with capillary
- covering plate with increased rigidity
- case with noise-absorbing foil (reduction of noisiness by 1 to 3 dB) see page 90

Note

- standard delivery is without regulation
- regulation must be ordered separately and according to technical parameters
- electrical regulation and regulation elements, see page 82
- regulation is identical for all OC convectors

Ordering codes Convectors KORAFLEX FI

			Length (cm)	Depth (cm)	Width (cm)	Case type – water supply location P on the right (looking out of room) L on the left (looking out of room)*			Convector case's face finish 0 without lowering of faces 1 supply side face lowering* 2 face lowering on opposite side of the supply* 3 lowering of both faces*			Frame type N not fitted with a frame* U U profile F F profile*	
Economic	black steel case ¹ /unpainted exchanger	FIE	-	N	P	0	R	U	1	
Exclusive*	black steel case/black exchanger	FIX	-	N	P	0	R	U	1	
Inox* ¹	stainless steel case/ unpainted exchanger	FII	-	N	P	0	R	U	1	

¹ Standard version for
KORAFLEX FI 11/20
* custom-made design

Floor convectors with forced convection
for heating or cooling KORAFLEX FI

Case with noise-ab-
sorbing foil
A Yes*
N No

Grid design
R lateral
L longitudinal*
* Only after consultation
with the manufacturer

Frame finish
0 not fitted with a frame*
1 aluminium/silver eloxal coat
2 aluminium/bronze
eloxal coat*
3 aluminium/light bronze
eloxal coat*

Ordering example

KORAFLEX FI, length 150 cm, depth 11 cm, width 20 cm, U sha-
pe frame, silver elxal coat, without Anti-noise foil and with possibi-
lity of adding lateral cover grid.

(standard only in Inox version (stainless steel AISI 304, unpainted exchanger))

Ordering code - KORAFLEX FIE1501120-NP0RU1

If the order does not include the specifications of the decorative
frame, case and heat exchanger the convector will be manufactu-
red in the standard finish:

11/20 Inox (stainless steel AISI 304 and unpainted exchanger)

13/34 Economic (black coated steel case and unpainted exchanger)

Correction factor page 63 • Assembly page 70 • Regulation page 82 • Floor grids page 18



Floor convectors with forced convection for heating and cooling KORAFLEX FW 13/34



- used for heating and cooling of rooms
- high heating and cooling output
- four-pipe system
- stainless-steel case for condensate drain
- possibility of control through BMS (Building Management System)
- can be ordered in Economic, Exclusive or Inox versions
- the convector is intended for dry environment

Specifications

width including the U/F type frame (mm)	344U/374F
floor case width (mm)	298
grid width (mm)	332
max. adjustable height (H max. mm)	133-160
case depth (mm)	133
length (L mm)	1 200, 1 500, 2 000, 2 500, 3 000
exchanger height (mm)	75
exchanger width (mm)	150
fans impeller diameter (mm)	60
connection to the heating system	4x G 1/2" inner
case material	galv. steel, stainless steel 304, 316

Version Economic • black coated galvanized steel with inner stainless steel case AISI 316, the heat exchanger without surface finish

Version Exclusive • black coated zinc galvanised steel case, black coated exchanger*

Version Inox • stainless steel unpainted case AISI 304, unpainted exchanger (for dry environment only)*

* custom-made design

Technical parameters

Width	cm	34																				
Depth	cm	13																				
Length	cm	120			150			200			250			300								
Noisiness - acoustic pressure 1m	dB(A)	0	28.6	33.1	39.3	0	28.9	33.5	39.8	0	29.3	34	40.4	0	29.6	34.4	40.9	0	29.9	34.8	41.4	
Max. input/voltage DC	W/V	9.5/12-24			14/12-24			18.5/12-24			23/12-24			27.5/12-24								
Rpm		Off	1	2	3	Off	1	2	3	Off	1	2	3	Off	1	2	3	Off	1	2	3	
Cooling output	t1 °C	Cooling output [W]																				
	hum. %	28	50	-	457	591	726	-	659	852	1046	-	995	1287	1580	-	1331	1722	2113	-	1668	2157
6/12 °C	26	50	-	406	525	644	-	585	757	929	-	884	1143	1403	-	1182	1529	1876	-	1481	1915	2350
	24	50	-	355	459	563	-	511	661	811	-	772	999	1225	-	1033	1336	1639	-	1294	1674	2053
	28	50	-	406	525	644	-	585	757	929	-	884	1143	1403	-	1182	1529	1876	-	1481	1915	2350
8/14 °C	26	50	-	355	459	563	-	511	661	811	-	772	999	1225	-	1033	1336	1639	-	1294	1674	2053
	24	50	-	304	393	482	-	438	567	695	-	661	856	1050	-	885	1145	1405	-	1108	1434	1759
	28	50	-	369	478	586	-	532	688	845	-	804	1040	1276	-	1075	1391	1707	-	1347	1742	2137
10/15 °C	26	50	-	318	412	505	-	459	594	728	-	693	897	1100	-	927	1199	1472	-	1161	1502	1843
	24	50	-	268	346	425	-	386	499	612	-	582	754	925	-	779	1008	1237	-	976	1263	1549
	28	50	-	369	478	586	-	532	688	845	-	804	1040	1276	-	1075	1391	1707	-	1347	1742	2137
Heat output	t1 °C	Heat output [W]/EN 442																				
		18	245	1629	2162	2696	353	2347	3116	3885	533	3545	4706	5867	713	4742	6296	7849	893	5940	7885	9831
75/65 °C	20	234	1557	2067	2577	337	2244	2979	3714	509	3389	4499	5609	681	4534	6019	7504	853	5678	7538	9398	
	22	223	1486	1972	2459	322	2141	2843	3544	486	3234	4293	5352	650	4326	5743	7160	814	5419	7194	8969	
70/55 °C	18	205	1362	1808	2255	295	1963	2606	3249	446	2965	3936	4907	596	3966	5266	6565	747	4968	6595	8223	
	20	194	1292	1715	2139	280	1862	2472	3082	423	2812	3734	4655	565	3763	4995	6228	708	4713	6256	7800	
	22	184	1223	1623	2024	265	1762	2339	2917	400	2661	3533	4405	535	3560	4726	5893	670	4459	5920	7381	
55/45 °C	18	140	933	1239	1545	202	1345	1785	2226	305	2031	2696	3362	408	2717	3607	4497	512	3403	4518	5633	
	20	130	867	1150	1434	188	1249	1658	2067	283	1886	2504	3122	379	2523	3350	4176	475	3161	4196	5231	
	22	120	801	1063	1325	173	1154	1532	1910	262	1743	2313	2884	350	2331	3095	3859	439	2920	3877	4833	

- temperature exponent m = 1.147

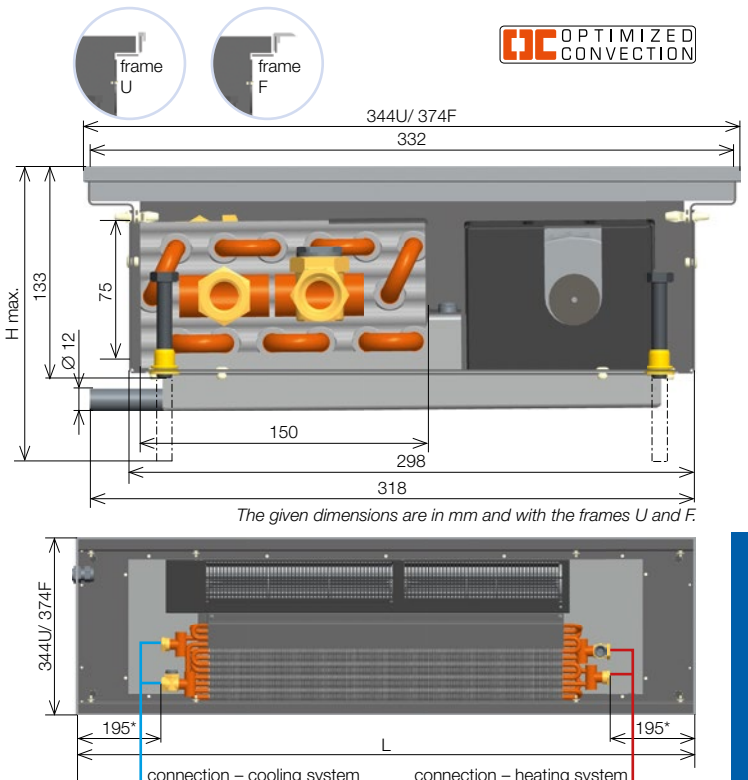

* For all manufactured lengths of KORAFLEX FW 13/34 the average distance for the connection is 195 mm.

* In case of floor convector KORAFLEX FW 13/34 the linear floor grid could not be manufactured as a standard product. Previous consultation is necessary and if possible the convector case is adapted.



Listed cooling outputs SENSITIV. Cooling outputs for other operating conditions on request.
* SENSITIV – cooling power actually delivered for cooling air.
Correction factor page 66 • Assembly page 70 • Regulation page 82 • Floor grids page 18

Correction factor k_t for a variant temperature difference Δt (K)

KORAFLEX FW 13/34

Δt (K)	18	19	20	21	22	23	24	25	26	27	28	29	30	31	32	33
k_t	0.310	0.330	0.350	0.370	0.390	0.410	0.431	0.452	0.472	0.493	0.514	0.535	0.557	0.578	0.599	0.621
Δt (K)	34	35	36	37	38	39	40	41	42	43	44	45	46	47	48	49
k_t	0.643	0.664	0.686	0.708	0.730	0.752	0.774	0.796	0.819	0.841	0.864	0.886	0.909	0.931	0.954	0.977
Δt (K)	50	51	52	53	54	55	56	57	58	59	60					
k_t	1.000	1.023	1.046	1.069	1.092	1.116	1.139	1.162	1.186	1.209	1.233					

• temperature exponent $m = 1.147$

Weights and water volumes

Type	13/34
steel kg/linear meter	14.5
stainless steel kg/linear meter	12.2
heating circuit l/linear meter	0.3
cooling circuit l/linear meter	1

The listed weights are without a packaging.

The contents of supplies and selectable specifications

Standard delivery contains

- galvanized steel case, coated in RAL 9005 – black
- Al/Cu heat exchanger with low water content and air vent
- group of low-energy fans
- connecting terminal (F Box)
- 2 temperature switches (heating, cooling)
- side covering metal sheets in the case colour
- anodized Al frame, U profile, in the natural aluminium colour
- fixing anchors for fastening the case to the floor
- a set of stainless-steel elastic hoses for easy connection
- chipboard cover plate protecting the heat exchanger from dust and dirt on building site
- 25 mm height adjustment screws to compensate the floor unevenness
- the unit is packed in a durable packaging and contains an installation manual

Optional accessories

- Exclusive or Inox finish
- colour of the anodized Al frame – natural aluminium, light and dark bronze in the F profile or light or dark bronze in the U profile, see sketch page 23
- closeable screwing, thermostatic valve and thermostatic head with capillary
- covering plate with increased rigidity
- case with noise-absorbing foil (reduction of noisiness by 1 to 3 dB), see page 90

Note

- standard supply does not include the regulation
- the regulation must be ordered separately in accordance with the technical parameters
- electrical regulation and regulation elements, see page 82
- regulation is identical for all OC convectors

Ordering codes Convectors KORAFLEX FW



			Length (cm)	Depth (cm)	Width (cm)	Case type – water supply location		Convector case's face finish			Frame type			
						P on the right (looking out of room)	L on the left (looking out of room)*	0 without lowering of faces	1 supply side face lowering*	2 face lowering on opposite side of the supply*	3 lowering of both faces*	N not fitted with a frame*	U U profile	F F profile*
Economic	black steel case/unpainted exchanger	FWE	...	13	34	-	N	P	0	R		U	1	
Exclusive*	black steel case/black exchanger	FWX	...	13	34	-	N	P	0	R		U	1	
Inox*	stainless steel case/unpainted exchanger	FWI	...	13	34	-	N	P	0	R		U	1	

* custom-made design

Floor convectors with forced convection for heating and cooling KORAFLEX FW

Case with noise-absorbing foil
A Yes*
N No

Grid design
R lateral
L longitudinal*
* Only after consultation with the manufacturer

Frame finish
0 not fitted with a frame*
1 aluminium/silver eloxal coat
2 aluminium/bronze eloxal coat*
3 aluminium/light bronze eloxal coat*

Ordering example

KORAFLEX FW, length 150 cm, depth 13 cm, width 34 cm with a black case and exchanger, U shape frame, silver eloxal coat = Exclusive finish, without Anti-noise foil and with possibility of adding lateral cover grid.

Ordering code – FWX1501334-NP0RU1

If the order does not specify the decorative frame, design of the case and the heat exchanger, the body will be made of black coated steel sheet with silver exchanger and fitted with a silver frame in the shape of U.

Assembly page 70 • Regulation page 82 • Floor grids page 18



Connecting the floor convectors KORAFLEX with forced convection

Case's types according to water inlets' location and lowering of faces for batch assembly

Lowering of faces of convector cases is used in places where visible connection of convectors to each other is not desirable (long rows of convectors, e.g. administrative buildings, hotels, etc.).

When ordering walkable grid it must be mentioned that it is for the lowered face convector (see ordering codes for walkable grids PM page 18).

 **Note:** The KORAFLEX FV InPool convectors' individual cases cannot be mutually interconnected. These are made only in P0 design.

Water inlet on the right

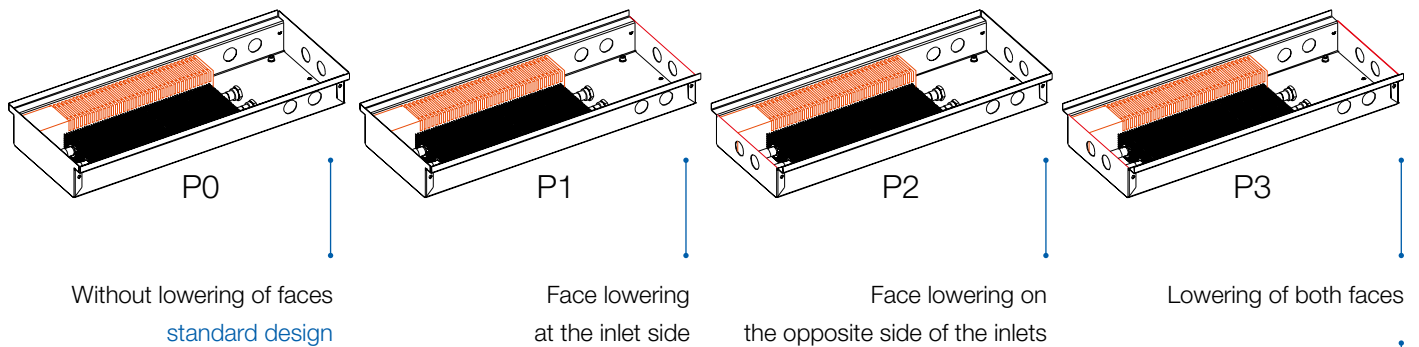

Water inlet on the left

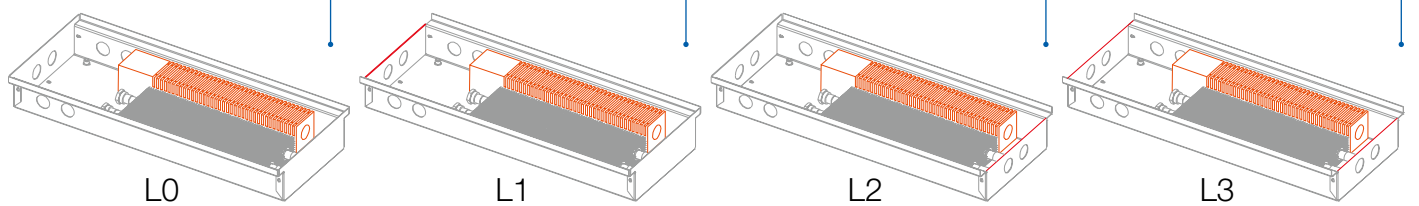

Profiles of aluminium frames

U frame

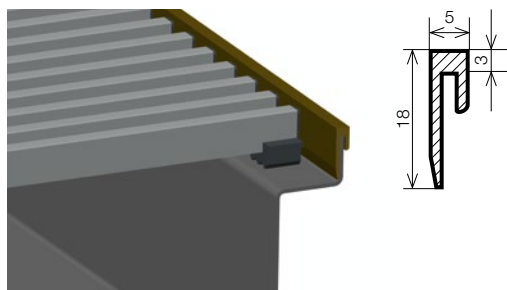

F frame

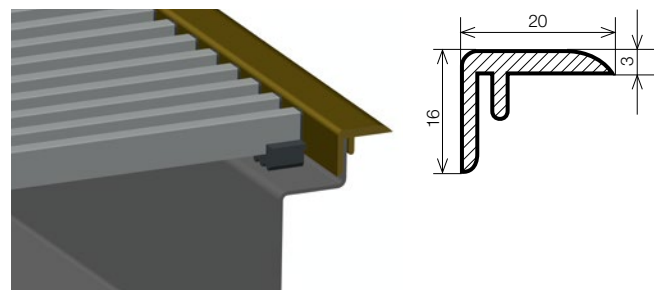

Sketches dimensions are in mm.

The convectors are fitted as standard with the silver U profile; when frame F is ordered it is enclosed with the delivery.
Colour finishes of the decorative frames match the colour finishes of the aluminium grids see page 19.

Information for the installation of convectors



Production series KORAFLEX FV

depth – 8 cm, width – 16 and 28 cm

length	max. input/max. voltage
80 cm	3 W/12–24 V DC
120 cm	5.5 W/12–24 V DC
160 cm	7.5 W/12–24 V DC
200 cm	10 W/12–24 V DC
240 cm	13 W/12–24 V DC
280 cm	15 W/12–24 V DC

Production series KORAFLEX FW and KORAFLEX FI

depth – 13 cm, width – 34 cm

length	max. input/max. voltage
120 cm	9.5 W/12–24 V DC
150 cm	14 W/12–24 V DC
200 cm	18.5 W/12–24 V DC
250 cm	23 W/12–24 V DC
300 cm	27.5 W/12–24 V DC

Production series KORAFLEX FV

depth – 9, 11 cm, width – 28, 34, 42 cm

Production series KORAFLEX FI and KORAFLEX FV

depth – 11 cm, width – 20 cm

Production series KORAFLEX FV InPool

depth – 11 cm, width – 34 cm

length	max. input/max. voltage
80 cm	5.5 W/12–24 V DC
120 cm	11 W/12–24 V DC
160 cm	12 W/12–24 V DC
200 cm	20 W/12–24 V DC
240 cm	22.5 W/12–24 V DC
280 cm	23.5 W/12–24 V DC



Convectors installation – construction part

KORAFLEX FV, FV InPool, FI and FW

Convectors installation – construction recommendations

Several general principles must be fulfilled to ensure proper functioning of the convector.

- A properly installed element has the exchanger located further away from the window.
- It is recommended to use the standard stainless-steel hoses with stainless-steel jacketing which always form a part of the delivery (unless recommended otherwise) for interconnecting the exchanger and the distributing pipeline. In practice they provide a better access under the heat exchanger without having to dismantle the heating system, e.g. during cleaning.
- We recommend connecting the heating system with the use of shut-off valves and a thermostatic valve.
- Always connect the supply of the heat-carrying medium to the heat exchanger's pipe that is further away from the fan. In case of the 34 cm width the KORABASE 30 heat exchanger is used; the heat-carrying medium enters through one pipe and leaves through another one.
- The KORAFLEX FW exchanger is a four pipe unit; one circuit feeds the heating circuit and the other one the cooling circuit.
- Properly installed convector is laid horizontally with the convector's case edges intact and not bent to ensure correct function of the walkable grid and the bleeding of the exchanger possible.
- Correctly installed convector's decorative frame is at the floor level with a margin of +2 mm.
- We recommend to keep the cover plate on the convector for the entire duration of the building work to prevent any dirt falling inside the convector. The standard plate is not walkable, but a plate with increased load bearing capacity can be ordered.
- The fans set is held down to the convector's case using magnets. In case of the stainless steel version the set of fans will be mounted using dry zips. This system allows you to remove the fans from the convector during the installation to avoid their damage or soiling, etc. They can be easily taken out for cleaning also during standard operation.
- The floor convector must be firmly set in the floor. The setting screws are only used for horizontal levelling of the convector case.
- Before concreting the convector must be fixed to the floor using anchoring screws that will prevent vertical shifting of the convector during subsequent pouring of concrete. When the concrete is poured the convector can be loaded vertically. During concreting the convector must be cross-braced to prevent deformation of the case. When pouring other material (e. g. anhydride) seal thoroughly all openings of the convector to prevent it from flooding.
- The convector's KORAFLEX FV InPool setting screw consists of a flag used as a ground anchor. This type does not contain anchors.
- We recommend the fixing and sound proof insulation to be done in such a way that will allow a thin concrete to be poured to the convector's bottom and its sides. Optimal noise reduction is achieved by direct embedding of the convector in concrete.
- Installing the fan convector in free space can result in increased noise, therefore we recommend to order a case with noise absorbing foil.
- Installation into double layer floors is described later.
- Convectors (KORAFLEX FI and FW) have built-in as standard a water (condensate) drain. During the installation do not forget to interconnect the case at the bottom of the convector with a pipeline with guaranteed gradient for wastewater or condensate removal. We recommend to equip the drain with an odour trap.
- Convectors KORAFLEX FV InPool are intended for use in swimming pool areas. The separation barrier is used to capture water from the pool, but cannot serve as the standard pool water overflow. This part is always placed closer to the pool. The heating part with the exchanger and fans must be always further away from the pool. The convector is provided with drainage holes in each corner, 2x. Installation, operation and maintenance of this equipment require special conditions. Please read them thoroughly on our website or in the manual.

Caution: Floor convector KORAFLEX FV InPool with forced convection must be positioned so as to prevent even short term flooding of the section fitted with the motor and the fans.

Section of correct convectors installation

Description and installation of the regulation see chapter titled Regulation page 82.

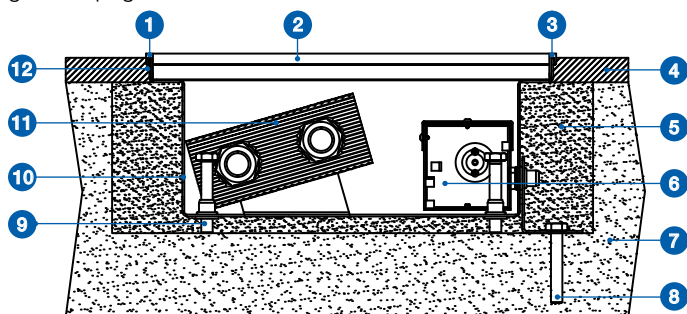

- | | |
|------------------|--------------------------------|
| 1 U frame | 7 subfloor |
| 2 walkable grid | 8 fixing anchor |
| 3 U frame | 9 height adjustment screw |
| 4 floor covering | 10 heat insulation |
| 5 concrete fill | 11 exchanger |
| 6 fan | 12 jointing material (silicon) |

The heat insulation is not part of the delivery.

Possibilities of convectors incorporation by floor types



Installation by embedding in concrete

The most frequent installation option – an opening is prepared in the floor for the installation of the convector, or the convector is directly embedded in concrete. The installation procedure is described in more detail in the Convector installation chapter – construction part. It is advisable to cross-brace the convector case before the concrete is cast to prevent its longitudinal deflection. It is also advisable to apply heat insulation (e.g. mineral wool, polystyrene) along the heat exchanger at the outer side of the case to avoid heat losses to the floor.

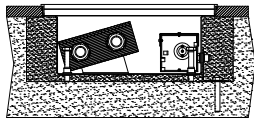

and around the convector we recommend to fit the convector case with noise absorbing foil to suppress the noise, see page 90. This design is suitable for loading under common usage.

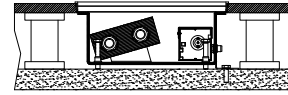

Installation in raised double floor

There is an individual design for every project. The installation procedure is the same as in option B, but instead of fixing anchors screws a steel beam or other aid is used to supports the convector along its full width. With regard to the free space under the floor and around the convector we recommend to fit the convector case with noise absorbing foil to suppress the noise, see page 90. The agreed technical design is based on the customer's requirements.

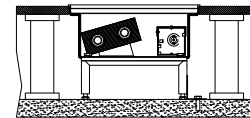

Installation in low double floor

In this case the convector must be fixed to the subfloor with the use of fixing anchors screws and aligned horizontally using the height adjustment screws. With regard to the free space under the floor

Dimensions of the mounting holes

KORAFLEX FV 8/16

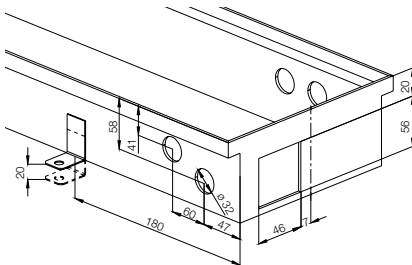

KORAFLEX FV 8/28 A=50, B=50 KORAFLEX FV 9/28 A=50, B=60

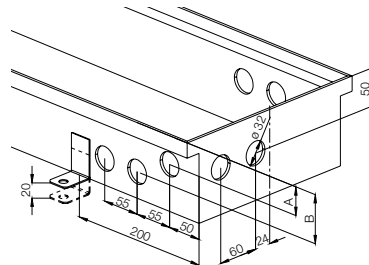

KORAFLEX FV

- 11/28 A=80, B=20, C=74, D=57
- 11/34 A=79, B=10, C=70, D=62
- 11/42 A=120, B=31, C=70, D=54

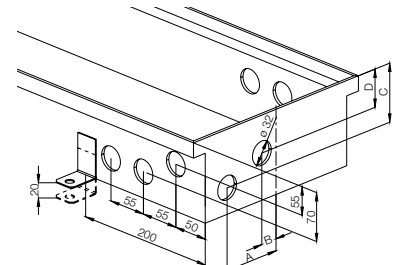

KORAFLEX FV 11/34 InPool

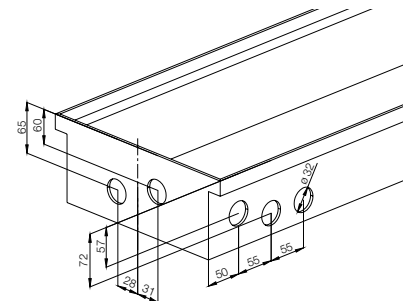

KORAFLEX FI 11/20 KORAFLEX FV 11/20

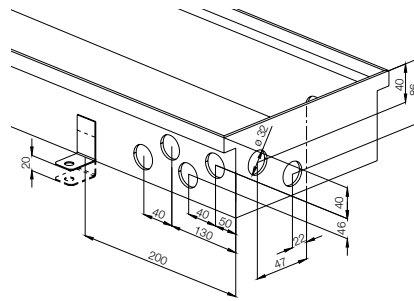

KORAFLEX FI 13/34

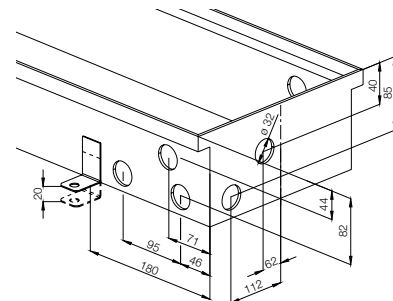

KORAFLEX FW 13/34

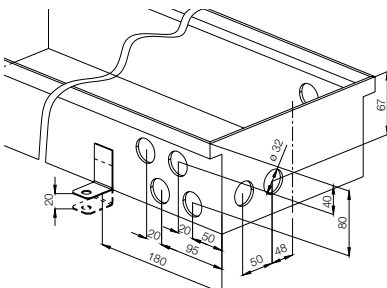



[KORALINE

FREE STANDING CONVECTORS with forced convection and optimized convection

Exclusive free standing convectors design enhanced by the state-of-the-art technologies. Universal design of the free standing convectors with high efficiency also at low temperature gradients. This predeterminates them as ideal system to be heated by heat pumps.

- high efficiency at low temperature of the heating water
- also suitable for installations with a heat pump
- energy efficient fans with an electric engine and a minimal input
- immediate reaction to temperature changes in the room
- very quiet operation



Free standing convectors with forced convection KORALINE LV 15/11



OC OPTIMIZED CONVECTION

- used for heating
- quietest operation at low speed
- also suitable for installations with a heat pump
- possibility of control through BMS (Building Management System)
- only bottom connection
- the convector is intended for dry environment

Specification

casing element height (mm)	150
width (mm)	111
length (L mm)	900, 1 200, 1 600, 2 000, 2 400, 2 800
exchanger height (mm)	50
exchanger width (mm)	50
exchanger approximate length (mm)	L - 300
fans' impeller diameter (mm)	30
connection to the heating system	2x inner G 1/2"

Version Exclusive • coated in RAL 9010 zinc galvanised steel with aluminium unpainted grid

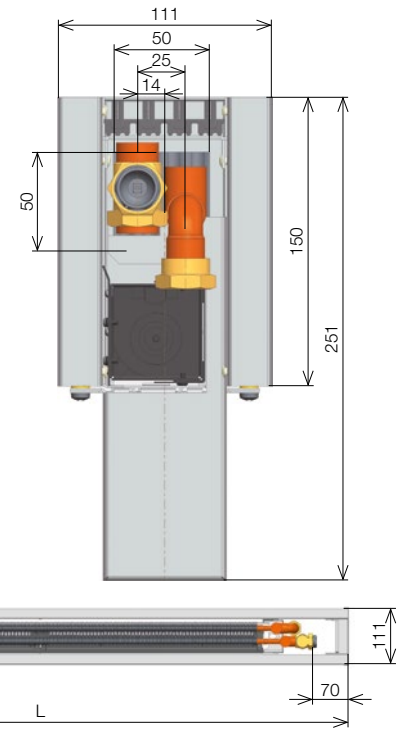

The given dimensions are in mm.

Technical parameters



Width	cm	11																							
Height	cm	15																							
Total length	cm	90				120				160				200				240				280			
Noisiness - acoustic pressure 1m	dB(A)	0	10.1	19.4	23.2	0	10.3	19.5	23.7	0	10.7	20.1	23.9	0	11.6	22.4	24.9	0	11.9	22.9	25.1	0	12	23.1	25.2
Power input	W/V	4/12-24				5.5/12-24				7.5/12-24				10.5/12-24				13/12-24				15/12-24			
Speed switch position		Off	1	2	3	Off	1	2	3	Off	1	2	3	Off	1	2	3	Off	1	2	3	Off	1	2	3
Heat output	t1 °C	Heat output [W]/EN 442																							
90/70 °C	20	160	366	498	629	240	550	746	943	347	794	1078	1362	453	1038	1410	1782	560	1282	1742	2201	667	1527	2073	2620
	18	139	318	431	545	208	476	647	817	300	688	934	1181	393	900	1222	1544	485	1111	1509	1907	578	1323	1797	2271
	22	128	293	398	503	192	440	597	755	277	635	863	1090	363	831	1128	1425	448	1026	1393	1761	533	1221	1659	2096
75/65 °C	20	113	260	352	445	170	389	529	668	246	562	764	965	321	735	999	1262	397	908	1234	1559	472	1081	1469	1856
	18	119	272	369	466	178	408	554	700	257	589	800	1010	336	770	1046	1321	415	951	1292	1632	494	1132	1538	1943
	22	108	247	336	424	162	371	504	637	234	536	728	920	306	701	952	1203	378	866	1176	1486	450	1031	1400	1769
70/55 °C	20	113	260	352	445	170	389	529	668	246	562	764	965	321	735	999	1262	397	908	1234	1559	472	1081	1469	1856
	18	119	272	369	466	178	408	554	700	257	589	800	1010	336	770	1046	1321	415	951	1292	1632	494	1132	1538	1943
	22	108	247	336	424	162	371	504	637	234	536	728	920	306	701	952	1203	378	866	1176	1486	450	1031	1400	1769
55/45 °C	20	85	195	265	335	128	293	398	503	185	423	575	727	242	554	752	950	299	684	929	1174	356	814	1106	1397
	18	85	195	265	335	128	293	398	503	185	423	575	727	242	554	752	950	299	684	929	1174	356	814	1106	1397
	22	75	171	232	293	112	256	348	440	162	370	503	636	212	484	658	831	261	598	813	1027	311	712	968	1223
50/40 °C	20	72	165	224	283	108	247	336	424	156	357	485	613	204	467	634	802	252	577	784	990	300	687	933	1179
	18	72	165	224	283	108	247	336	424	156	357	485	613	204	467	634	802	252	577	784	990	300	687	933	1179
	22	61	140	191	241	92	211	286	362	133	304	413	522	174	398	540	683	215	492	668	844	256	585	795	1004
45/35 °C	20	59	134	182	231	88	202	274	346	127	291	395	500	166	381	517	653	205	470	639	807	244	560	760	961
	18	59	134	182	231	88	202	274	346	127	291	395	500	166	381	517	653	205	470	639	807	244	560	760	961
	22	48	110	149	189	72	165	224	283	104	238	323	409	136	311	423	534	168	385	522	660	200	458	622	786

• temperature exponent m = 1

Correction factor page 76 • Assembly page 77 • Regulation page 82

Free standing convectors with forced convection

KORALINE LV 15/18



- used for heating
- high heat output
- possibility of control through BMS (Building Management System)
- only bottom connection
- the convector is intended for dry environment

Specification

casing element height (mm)	150
width (mm)	176
length (L mm)	900, 1 200, 1 600, 2 000, 2 400, 2 800
exchanger height (mm)	50
exchanger width (mm)	100
exchanger approximate length (mm)	L - 300
fans' impeller diameter (mm)	40
connection to the heating system	2x G 1/2" inner

Version Exclusive • coated in RAL 9010 zinc galvanised steel with aluminium unpainted grid

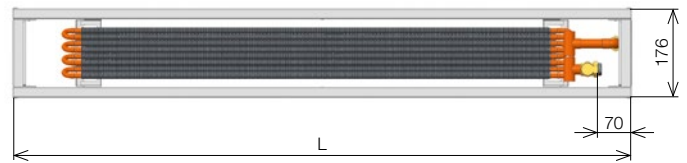
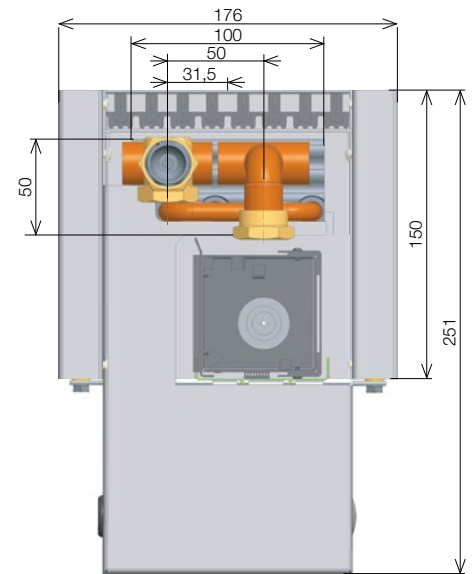

The given dimensions are in mm.



Technical parameters

Width	cm	18																							
Height	cm	15																							
Total length	cm	90				120				160				200				240				280			
Noisiness - acoustic pressure 1m	dB(A)	0	17.6	26.3	33	0	17.9	26.8	33.4	0	18.2	27.1	33.6	0	18.7	27.7	33.9	0	18.9	27.8	34.2	0	19.2	28	34.4
Power input	W/V	8/12-24				11/12-24				12/12-24				21.5/12-24				22.5/12-24				23.5/12-24			
Speed switch position		Off	1	2	3	Off	1	2	3	Off	1	2	3	Off	1	2	3	Off	1	2	3	Off	1	2	3
Heat output	t1 °C	Heat output [W]/EN 442																							
90/70 °C	20	250	1025	1208	1392	376	1537	1813	2088	543	2220	2618	3016	709	2904	3424	3944	876	3587	4229	4872	1043	4270	5035	5800
	18	217	888	1047	1206	326	1332	1571	1810	470	1924	2269	2614	615	2517	2967	3418	760	3109	3666	4222	904	3701	4364	5027
	22	200	820	967	1114	300	1230	1450	1670	434	1776	2095	2413	568	2323	2739	3155	701	2869	3384	3898	835	3416	4028	4640
75/65 °C	20	209	854	1007	1160	313	1281	1511	1740	452	1850	2182	2513	591	2420	2853	3287	730	2989	3525	4060	869	3558	4196	4833
	18	186	760	896	1032	279	1140	1344	1549	402	1647	1942	2237	526	2154	2539	2925	650	2660	3137	3613	774	3167	3734	4302
	22	169	692	816	940	254	1038	1224	1409	366	1499	1767	2036	479	1960	2311	2662	592	2421	2855	3289	704	2882	3399	3915
70/55 °C	18	134	547	644	742	200	820	967	1114	289	1184	1396	1609	378	1549	1826	2103	467	1913	2256	2598	556	2277	2685	3093
	20	177	726	856	986	266	1089	1284	1479	384	1573	1855	2136	503	2057	2425	2794	621	2541	2996	3451	739	3025	3567	4108
	22	169	692	816	940	254	1038	1224	1409	366	1499	1767	2036	479	1960	2311	2662	592	2421	2855	3289	704	2882	3399	3915
55/45 °C	18	113	461	544	626	169	692	816	940	244	999	1178	1357	319	1307	1541	1775	394	1614	1903	2192	470	1922	2266	2610
	20	104	427	504	580	157	641	755	870	226	925	1091	1257	296	1210	1427	1643	365	1495	1762	2030	435	1779	2098	2417
	22	96	393	463	534	144	589	695	800	208	851	1004	1156	272	1113	1313	1512	336	1375	1621	1868	400	1637	1930	2223
45/35 °C	18	92	376	443	510	138	564	665	766	199	814	960	1106	260	1065	1255	1446	321	1315	1551	1786	383	1566	1846	2127
	20	83	342	403	464	125	512	604	696	181	740	873	1005	236	968	1141	1315	292	1196	1410	1624	348	1423	1678	1933
	22	75	307	363	418	113	461	544	626	163	666	785	905	213	871	1027	1183	263	1076	1269	1462	313	1281	1511	1740

• temperature exponent m = 1

Correction factor page 76 • Assembly page 77 • Regulation page 82

Free standing convectors with forced convection KORALINE LV 15/24



OC OPTIMIZED CONVECTION

- used for heating
- high heat output
- quietest operation at low speed
- possibility of control through BMS (Building Management System)
- only bottom connection
- the convector is intended for dry environment

Specification

casing element height (mm)	150
width (mm)	236
length (L mm)	900, 1 200, 1 600, 2 000, 2 400, 2 800
exchanger height (mm)	50
exchanger width (mm)	150
exchanger approximate length (mm)	L - 260
fans' impeller diameter (mm)	40
connection to the heating system	2x G 1/2" inner

Version Exclusive • coated in RAL 9010 zinc galvanised steel with aluminium unpainted grid

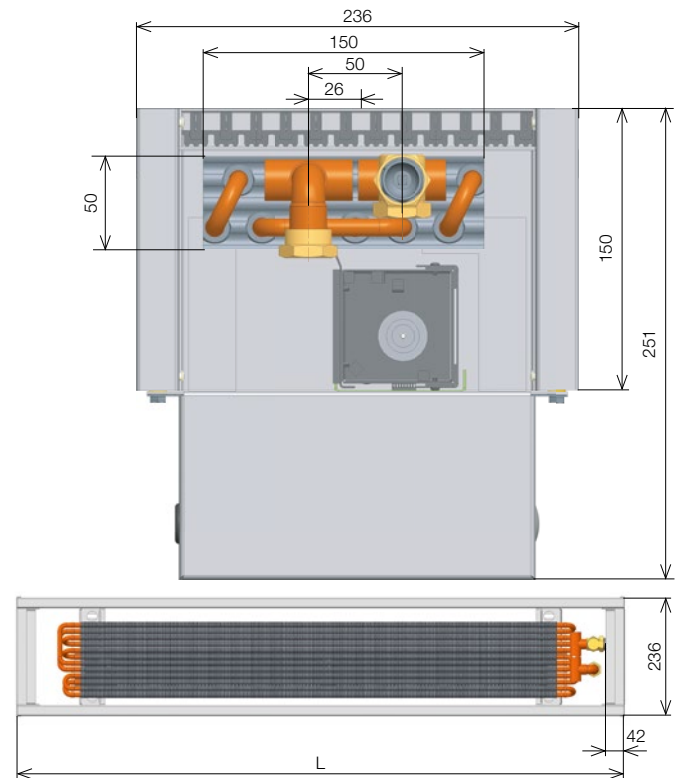

The given dimensions are in mm.



Technical parameters

Width	cm	24																							
Height	cm	15																							
Total length	cm	90				120				160				200				240				280			
Noisiness - acoustic pressure 1m	dB(A)	0	17.6	26.3	33	0	17.9	26.8	33.4	0	18.2	27.1	33.6	0	18.7	27.7	33.9	0	18.9	27.8	34.2	0	19.2	28	34.4
Power input	W/V	8/12-24				11/12-24				12/12-24				21.5/12-24				22.5/12-24				23.5/12-24			
Speed switch position		Off	1	2	3	Off	1	2	3	Off	1	2	3	Off	1	2	3	Off	1	2	3	Off	1	2	3
Heat output	t1 °C	Heat output [W]/EN 442																							
90/70 °C	20	313	1183	1508	1833	460	1738	2215	2692	655	2477	3157	3837	851	3216	4099	4982	1046	3956	5042	6128	1242	4695	5984	7273
	18	271	1025	1307	1588	398	1506	1919	2333	568	2147	2736	3325	737	2788	3553	4318	907	3428	4370	5311	1076	4069	5186	6303
	22	250	946	1206	1466	368	1390	1772	2153	524	1982	2526	3070	681	2573	3279	3986	837	3165	4033	4902	994	3756	4787	5818
75/65 °C	20	261	986	1257	1527	383	1448	1846	2243	546	2064	2631	3197	709	2680	3416	4152	872	3297	4201	5106	1035	3913	4987	6061
	18	232	877	1118	1359	341	1289	1642	1996	486	1837	2341	2846	631	2386	3040	3695	776	2934	3739	4545	921	3482	4438	5394
	22	211	799	1018	1237	310	1173	1495	1817	442	1672	2131	2590	574	2171	2767	3363	706	2670	3403	4136	838	3169	4039	4909
70/55 °C	18	167	631	804	977	245	927	1181	1436	349	1321	1684	2046	454	1715	2186	2657	558	2110	2689	3268	662	2504	3192	3879
	20	222	838	1068	1298	326	1231	1569	1907	464	1755	2236	2718	603	2278	2904	3529	741	2802	3571	4340	880	3326	4239	5152
	22	211	799	1018	1237	310	1173	1495	1817	442	1672	2131	2590	574	2171	2767	3363	706	2670	3403	4136	838	3169	4039	4909
55/45 °C	18	141	532	679	825	207	782	997	1211	295	1115	1421	1727	383	1447	1845	2242	471	1780	2269	2757	559	2113	2693	3273
	20	130	493	628	764	192	724	923	1122	273	1032	1315	1599	354	1340	1708	2076	436	1648	2101	2553	517	1956	2493	3030
	22	120	454	578	702	176	666	849	1032	251	950	1210	1471	326	1233	1571	1910	401	1516	1933	2349	476	1800	2294	2788
45/35 °C	18	115	434	553	672	169	637	812	987	240	908	1158	1407	312	1179	1503	1827	384	1450	1849	2247	455	1722	2194	2667
	20	104	394	503	611	153	579	738	897	218	826	1052	1279	284	1072	1366	1661	349	1319	1681	2043	414	1565	1995	2424
	22	94	355	452	550	138	521	664	807	197	743	947	1151	255	965	1230	1495	314	1187	1513	1838	373	1409	1795	2182

• temperature exponent m = 1

Correction factor page 76 • Assembly page 77 • Regulation page 82

Correction factor k_t for a variant temperature difference Δt (K)

KORALINE LV 15/11, 15/18, 15/24

Δt (K)	18	19	20	21	22	23	24	25	26	27	28	29	30	31	32	33
k_t	0.360	0.380	0.400	0.420	0.440	0.460	0.480	0.500	0.520	0.540	0.560	0.580	0.600	0.620	0.640	0.660
Δt (K)	34	35	36	37	38	39	40	41	42	43	44	45	46	47	48	49
k_t	0.680	0.700	0.720	0.740	0.760	0.780	0.800	0.820	0.840	0.860	0.880	0.900	0.920	0.940	0.960	0.980
Δt (K)	50	51	52	53	54	55	56	57	58	59	60					
k_t	1.000	1.020	1.040	1.060	1.080	1.100	1.120	1.140	1.160	1.180	1.200					

• temperature exponent $m = 1.1$

Weights and water volumes of free standing convectors

KORALINE LV	15/11	15/18	15/24
kg/linear meter	9.2	11.21	12.10
l/linear meter	0.28	0.6	0.85

The listed weights are without a packaging.

The contents of supplies and selectable specifications

Standard delivery contains

- sheathing of zinc galvanised steel coated in shade RAL 9010 – white
- Al/Cu heat exchanger with low water content, air vent and uniquely shaped lamellas for a higher heat output
- group of low-energy fans
- connecting terminal (F Box)
- temperature switch
- stands for fixing to floor covering (it is not possible to use the wall mounting brackets or stands for the subfloor with the KORALINE LV product)
- the set is packed in a cardboard packaging

Optional accessories

- shutt of valve and thermoelectric drive
- in case of ordering more than 5 units it is possible to select another sheathing colour shade (the manufacturer must be consulted)

Note

- standard supply does not include the regulation
- the regulation must be ordered separately in accordance with the technical parameters
- electrical regulation and regulation elements, see page 82
- regulation is identical for all OC convectors



Convectors assembly



KORALINE LV

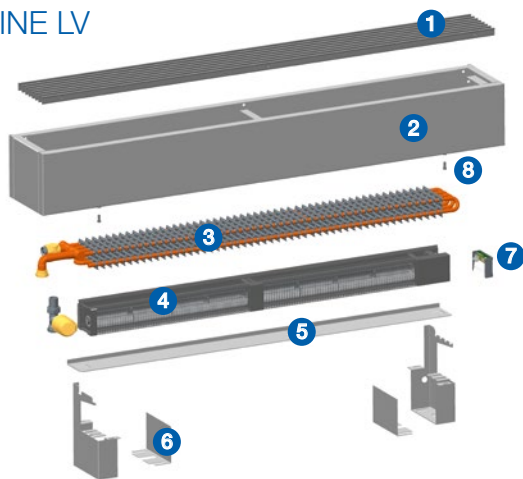

Convectors breakdown

- 1 aluminium cover grid
- 2 metal plating
- 3 heat exchanger KORABASE 20
- 4 fans
- 5 fan support
- 6 stands
- 7 connecting terminal (F Box)
- 8 screw DIN 7981

Installation technique for KORALINE LV (valid for all models)

Determine the stands spacing for anchoring them to the floor by pushing the fan's rail into the stands. The heat exchanger is then positioned in the stands and connected to the heating system.

The fan is fixed to the fan support and connected to the F-box. Finally, the cover with the cover grid is put on and screwed onto the stands. The grid is removable for easy cleaning. You will find more detailed information in the installation instructions.

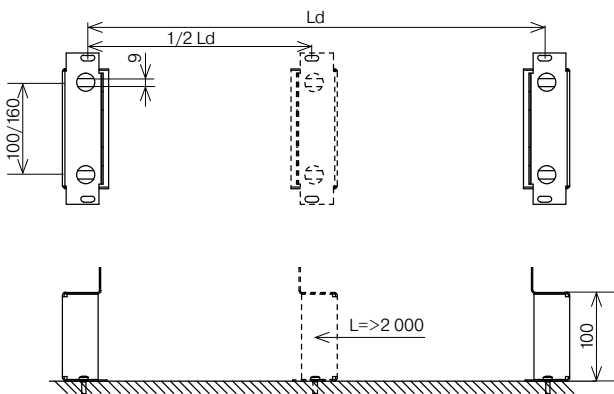

L = Convector length

Ld = L - 300 mm (up to the convector length of 1 400 mm)

Ld = L - 400 mm (up to the convector length of 2 000 mm)

Ld = L - 600 mm (above the convector length of 2 000 mm)



Note: For the heating benches of more than 2 m in length we recommend installing 2 pairs of stands on a subfloor, or alternatively 2 pairs of wall brackets.

Ordering codes KORALINE LV

Exclusive	white steel/unpainted exchanger	LVX	Length (cm)	Height (cm)	Width (cm)	Colour	
			...	15	..	-	10

Free standing convectors with forced convection KORALINE LV



[KORAWALL

WALL MOUNTED CONVECTORS

with forced convection and optimized convection

Developed for low temperature heating systems, high efficiency guaranteed also at very low temperature gradients, e.g. 35/30 °C. Ideal everywhere where the heat source is a heat pump, a solar system, a condensation boiler or as a supplementary source of heat for floor heating, particularly during a transitional period or when an instant temperature increase in the room is required. At the same time suitable for rooms' dry-cooling during the summer months. All of this with the benefits of the Optimized Convection system – low noise and low fan input while maintaining maximally attainable performances.

Univeral use – heating and dry-cooling!



Wall mounted convectors with forced convection KORAWALL WI 45/11



- used for heating or dry-cooling
- high efficiency even at low temperatures of the heating system
- patented design solutions
- high-performance, low energy and quiet fans
- the same regulation as the one for floor convectors
KORAFLEX FV and free standing convector with forced convection KORALINE LV
- two-pipe system
- right bottom connection
- possibility of control through BMS
(Building Management System)
- the convector is intended for dry environment

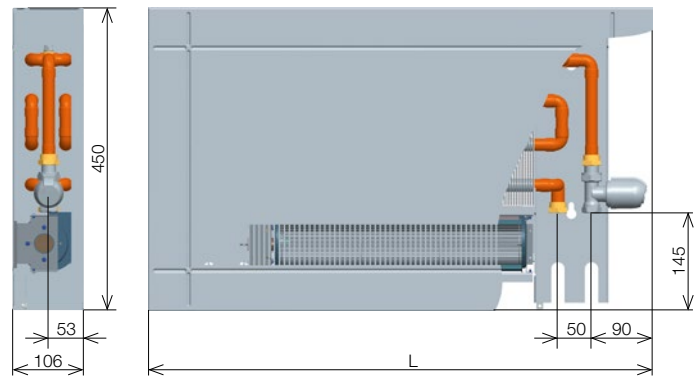

The given dimensions are in mm.

Specification

height (mm)	450
depth (mm)	106
length (L mm)	750, 1 000, 1 250, 1 500, 1 750, 2 000
exchanger height (mm)	240
exchanger width (mm)	100
fans' impeller diameter (mm)	60
connection to the heating system	inner G 1/2"
connection method	recommended bottom connection, right

Version KORAWALL WI • coated in RAL 9010 zinc galvanised steel

Technical parameters



Height	cm	45																							
Depth	cm	11																							
Length	cm	75				100				125				150				175				200			
Noisiness - acoustic pressure 1m	dB(A)	0	23.1	31.3	38	0	23.4	31.7	38.5	0	23.7	32.1	39	0	24	32.5	39.5	0	24.4	33	40.1	0	24.7	33.4	40.6
Max. input/voltage DC	W/V	5.5/12-24				8/12-24				9.5/12-24				14/12-24				16/12-24				18.5/12-24			
Rpm		Off	1	2	3	Off	1	2	3	Off	1	2	3	Off	1	2	3	Off	1	2	3	Off	1	2	3
Cooling output	t1 °C/hum. %	Cooling output [W]																							
16/19 °C	28 50	0	149	207	263	0	291	407	527	0	387	542	703	0	434	604	791	0	523	732	966	0	618	864	1141
	26 50	0	123	171	218	0	240	337	435	0	320	448	581	0	359	499	653	0	432	605	798	0	510	714	943
	24 50	0	93	128	163	0	180	252	327	0	241	336	435	0	270	375	490	0	323	454	598	0	383	536	708
Heat output	t1 °C	Heat output [W]/EN 442																							
75/65 °C	18	281	858	1139	1444	563	1716	2279	2888	751	2288	3039	3850	844	2574	3418	4332	1032	3146	4178	5294	1220	3718	4938	6257
	20	270	823	1093	1385	540	1646	2186	2770	720	2195	2915	3693	810	2469	3279	4155	990	3018	4008	5078	1170	3566	4736	6002
	22	259	788	1047	1326	517	1576	2093	2652	689	2102	2791	3537	776	2364	3140	3979	948	2890	3838	4863	1120	3415	4535	5747
70/55 °C	18	239	727	966	1224	477	1454	1932	2448	636	1939	2575	3263	716	2182	2897	3671	875	2666	3541	4487	1034	3151	4185	5303
	20	227	693	920	1165	454	1385	1839	2331	606	1847	2453	3108	682	2078	2759	3496	833	2539	3372	4273	985	3001	3986	5050
	22	216	658	874	1107	432	1316	1748	2215	576	1755	2330	2953	648	1974	2622	3322	791	2413	3204	4060	935	2851	3787	4798
55/45 °C	18	168	512	680	862	336	1025	1361	1724	448	1366	1814	2299	504	1537	2041	2587	616	1879	2495	3161	728	2220	2949	3736
	20	157	478	635	805	314	957	1271	1610	419	1276	1694	2147	471	1435	1906	2415	575	1754	2330	2952	680	2073	2753	3489
	22	146	445	590	748	292	889	1181	1496	389	1186	1575	1995	438	1334	1771	2245	535	1630	2165	2743	632	1927	2559	3242
50/40 °C	18	140	428	568	720	281	856	1136	1440	374	1141	1515	1920	421	1283	1704	2160	515	1568	2083	2640	608	1854	2462	3119
	20	129	394	524	663	259	788	1047	1327	345	1051	1396	1769	388	1183	1571	1990	474	1445	1920	2432	560	1708	2269	2875
	22	118	361	479	607	237	722	958	1214	316	962	1278	1619	355	1082	1437	1821	434	1323	1757	2226	513	1563	2076	2631

- temperature exponent $m = 1.062$

**Cooling is possible only in the non-condensation zone, i.e. above the temperature of the dew-point.
The element is not provided with condensate drain. Listed cooling outputs SENSITIV.**

Cooling outputs for other operating conditions on request.

* SENSITIV - cooling power actually delivered for cooling the air.

Correction factor page 80 • Assembly page 81 • Regulation page 82

Correction factor k_t for a variant temperature difference Δt (K)

KORAWALL WI 45/11

Δt (K)	18	19	20	21	22	23	24	25	26	27	28	29	30	31	32	33
k_t	0.338	0.358	0.378	0.398	0.418	0.438	0.459	0.479	0.499	0.520	0.540	0.561	0.581	0.602	0.623	0.643
Δt (K)	34	35	36	37	38	39	40	41	42	43	44	45	46	47	48	49
k_t	0.664	0.685	0.705	0.726	0.747	0.768	0.789	0.810	0.831	0.852	0.873	0.894	0.915	0.936	0.958	0.979
Δt (K)	50	51	52	53	54	55	56	57	58	59	60					
k_t	1.000	1.021	1.043	1.064	1.085	1.107	1.128	1.149	1.171	1.192	1.214					

- temperature exponent $m = 1.062$

Weights and water volumes of the wall mounted radiator KORAWALL WI

Type	45/11
kg/linear meter	18.2
l/1 linear meter	1.4

The listed weights are without a packaging.

The contents of supplies and selectable specifications

Standard delivery contains

- sheathing of zinc galvanised steel coated in shade RAL 9010 – white
- Al/Cu heat exchanger with low water content, air vent and uniquely shaped lamellas for a higher heat output
- group of low-energy fans
- connecting terminal (F Box)
- wall-mounting brackets
- mounting instructions
- the set is packed in a cardboard packaging

Optional accessories

- in case of ordering more than 5 units it is possible to select another sheathing colour shade (the manufacturer must be consulted)
- closeable screwing, thermostatic valve and thermostatic head with capillary

Note

- standard supply does not include the regulation
- the regulation must be ordered separately in accordance with the technical parameters
- electrical regulation and regulation elements, see page 82
- regulation is identical for all OC convectors



Convectors installation – construction recommendations

KORAWALL WI



- It is recommended to position the wall mounted heating element on a peripheral wall, 10 cm above the floor.
- The hot water is supplied always in the upper pipes; recommend to fit with the shut-off valve and the thermostatic valve (consultation with the designer is required in case of cooling).
- We recommend to fit the fans once all building work is completed. The exchanger and the sheathing must be well protected against fouling and regular maintenance carried out – including cleaning of exchangers and fans.
- The convector is fitted to the wall using brackets. Then the heat exchanger is inserted and connected to the heating system. We recommend to check the correct position of the exchanger and the fittings in relation to the sheathing. Fit the fans and the sheathing only after all building work has been completed.

Anchoring diagram

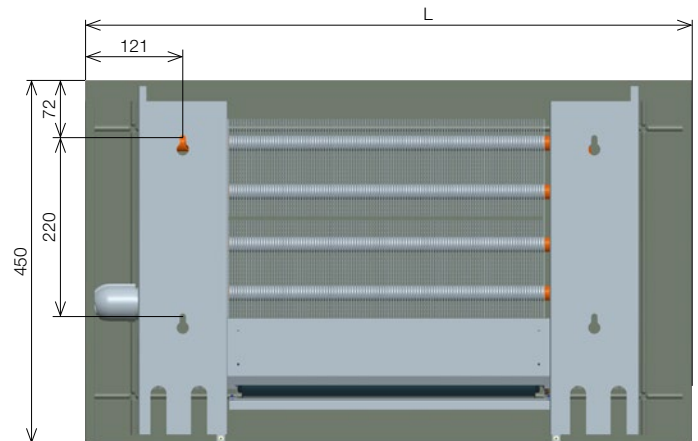

Assembly electrical part

- Regulation is identical with OC convectors
- We recommend to fit KORAWALL WI with the thermoelectric drive
- Do not forget to provide power supply near the installation – more details in the electrical assembly part on page 82 or in the installation instructions

Design solution of the front face of KORAWALL WI

The wall mounted heating elements KORAWALL WI have on their front face a significant design element which consists of one design section in the lengths of 75, 100 and 125 cm, two sections in the lengths of 150 and 175 cm and three sections in the length of 200 cm.



Note: Easily removable cover for better access to the heat exchanger (for instance for easier cleaning).

Ordering codes

Convectors KORAWALL WI

				Length (cm)	Height (cm)	Depth (cm)	Colour
KORAWALL	white steel/unpainted exchanger	WI	-	...	45	11	- 10

Wall mounted convectors with forced convection KORAWALL WI



Regulation and acoustics





Description of electrical regulation of KORAFLEX FV, FV InPool, FI, FW, KORALINE LV and KORAWALL WI (hereinafter referred to as fan-coils)

Standard regulation:

The regulation is designed for the control of the heating and cooling output of convectors with blow fans. The standard part of the fans is:

- Group of fans with a unique disk type synchronous engine with permanent magnets. It is characterized mainly by very low power consumption – the power input of the engine at the full range of speed does not exceed 7.5 watts; the engine also runs very quietly.
- Connecting terminal (F Box)
- Exchanger temperature sensor (switch)

Optional accessories

The DC power supply source in accordance with the total power input of the controlled fan-coil units. Four types of power sources, rated at 12 V/60 W, 12 V/100 W, 24 V/100 W and 24 V/480 W, are available. The power supply sources are supplied separately for installation in the electrical switchboard on DIN rail.

- R-Box, containing the speed signal galvanic separation module, controlling the fan speed and which also allows the selection and optimization of various degrees of speed. The R-Box is designed for mounting on DIN rail in the switchboard
- Plastic box for the placement of the DC power supply and the R-Box for installations where the switchboard is too far
- Siemens thermostats
- Valves, thermoelectric drive 12 V DC and 24 V DC

Description of function with 12 V DC:

The performance is controlled by the working media On/Off switching valve, if used, and by switching the On/Off the three speed blower fan. When using a Siemens thermostat RDG100T and RDF 600T the speed is controlled automatically. All three speeds of the fan can be smoothly adjusted. The fan speed is given by the size of the voltage control signal CNTRL from the galvanic separation signal module (R-Box). Detailed description of functions and settings is available in the installation instructions supplied with the producer on www.licon.cz in the download section.

Fans are normally blocked by a temperature switch (TS1) at a switching temperature of about 35 °C. This function may be disconnected. This accessory is not supplied for KORAWALL WI. For fan coils with dry-cooling effect it is still necessary to use one cooling medium thermal switch (TS2) connected in parallel to the temperature switch which activates at a temperature below 13 °C. The temperature and speed is controlled by Siemens Thermostats RAB11, RDF 600T or

RDG 100T. Contact fields of these thermostats (TS1) are connected to mains voltage, and that is why it is necessary to use the R-Box signals' galvanic separation (the galvanic separation of signals is implemented by using optocouplers). The thermostat switches the DC power supply source of the output voltage of approx. 12 V. Once the power supply source is switched on the heating medium valves (if used) start opening. Furthermore, the thermostat through galvanic separation module generates the control voltage signal CNTRL. The control voltage signal is of three levels, with each speed level smoothly adjustable. The standard regulation enables the use of a thermoelectric drive 12 V DC that closes or opens the heating media valve. The function is set in such a way that if heating is required, i.e. after the thermostat switches on, the power supply is activated. The voltage from the power supply source directly supplies the thermoelectric drives of the valve for the control of the heating media inlet to the fan-coil unit. If the heating output is not sufficient without the fan, it is possible to select the required speed of the fan (I. II. III.) with a switch. The standard control allows usage of a 12 V DC actuator, which closes or opens the heating media valve. The function is set in such a way that when the need arises to provide heat, i.e. once the thermostat switches on, the supply source is activated. The supply source feeds directly the valve actuators controlling the heating media entry into the fan-coils.

Description of function with 24 V DC:

The performance is controlled by switching On/Off the working medium valve – provided such valve is implemented – and by switching On/Off the blowing fan. The convector is under permanent voltage of 24 V. The thermostat Siemens RDG 160T controls via thermoelectric drive the valve of the heating media as On/Off and furthermore it controls the speed of the fan via voltage signal 0–10 V. The speed of the fan may be controlled automatically or manually in three speed levels. The speed levels may be adjusted. The fans are as standard blocked by temperature switch (TS1) at switching temperature of about 35 °C. This function may be disconnected (This accessory is not supplied for KORAWALL WI). As for fan coils with cooling effect the second thermal switch (TS2) for cooling media is implemented to switch On when the temperature falls below 13 °C.

BMS (Building Management System):

The convectors control can be also carried out using a BMS (Building Management System) higher-level output elements. One BMS relay output controls the valve's opening/closing, and the second continuous 0–10 V output controls the speed. Supply voltage of 12–24 V DC can be used.

Description of regulation of KORAFLEX FV InPool

The above described system of regulation applies to pool applications for which this product is intended. The principle is the same but

the electrical equipment of the convector differs the electronics of the motor, F box are located in a plastic box with high degree of protection IP 67 which is placed inside the convector. When installing the connecting cables to the terminal block of the F box must be connected as per instructions. In terms of temperature and speed regulation the same types and variations of thermostats are used with a restriction that the thermostats must not be placed in the pool area. For these purposes we recommend using the temperature sensor which senses the temperature in the pool area, see Accessories. The sensor is designed for thermostats RDF 600T and RDG 100T.

The convector is not designed for continuous flooding by pool water. Get thoroughly familiar with the warranty and operating conditions.

Installation must be performed according to valid standards and safety regulations! The manufacturer is not liable for defects or damage caused by improper installation.

Electrical regulation elements

SIEMENS RAB 11 (for 12 V regulation)

- room thermostat with a speed switch
- switching between heating and cooling
- manual switching of the fan speed
- voltage 24 to 250 V AC, current 0.2 to 6 (2) A
- temperature setting range 8 to 30 °C
- degree of protection class IP 30
- dimensions w × h × d (mm) – 96 × 110 × 35.4



SIEMENS IRA 211

- infrared remote control for RDF 600/IR and RDG 100T
- operation type selection
- temperature setting
- fan speed selection
- compatible for use with the RDF 600, RDG 100T thermostats
- power supply 2× 1.5 V, AAA type
- degree of protection class IP 30
- dimensions w × h × d (mm) – 42 × 106 × 18



SIEMENS RDF 600T (for 12 V regulation)

- room thermostat with a display and weekly program for two/four-pipe fan-coil units
- automatic switching between heating/cooling
- manual or automatic 3-stage fan speed control
- operating voltage AC 230 V, current loading max. 4 (2) A
- setting range of the required temperature 5–40 °C
- switching hystereses adjustable in the range of 0.5 to 4 K
- possibility of connection of a separate sensor e.g. for applications in a wet environment
- possibility to control the control valve with the use of a thermoelectric drive
- degree of protection class IP 30
- dimensions w × h × d (mm) – 86 × 86 × 57



Room temperature sensor QAA32

- to measure space temperature in systems of heating where it is not possible to place a thermostat
- suitable for pool application installations
- can be connected to thermostats RDF 600, RDG 100T
- measurement range: 0–40 °C, accuracy of measurement at 25 °C ± 0.3 K
- measuring sensor – NTC, 3 kΩ at 25 °C
- safety class II according to EN 60 730, degree of protection IP 30 according to EN 60 529
- dimensions w × h × d (mm) – 96.4 × 99.6 × 36



SIEMENS RDG 100 T (for 12 V regulation) SIEMENS RDG 160 T (for 24 V regulation)

- room thermostat with a display and weekly program for two/four-pipe fan-coil units
- automatic switching between heating/cooling
- manual or automatic 3-stage fan speed control
- supply voltage, maximum current loading:
RDG 100T – AC 230V, Y1-Y4 max. 5 (4) A
RDG 160T – DC 24V, Y50 DC 0...10 V max. 1mA
- setting range of the required temperature 5–40 °C
- switching hystereses adjustable in the range of 0.5 to 6 K
- possibility of connection of a separate sensor e.g. for applications in a wet environment
- possibility of control using the infrared remote control
- degree of protection class IP 30
- dimensions w × h × d (mm) – 93 × 128 × 30



DC power supply source 60 W, 100 W, 480 W

- switching DC power supply
- noiseless operation, high efficiency
- DIN rail mounting
- degree of protection class IP 20



model	DR-60-12	DR-100-12
power supply size	60 W	100 W
input control voltage	230 V AC/0.88 A	230 V AC/1.6 A
heat output voltage	12 V DC/4 A	12 V DC/6.5 A
dimensions w × h × d (mm)	78 × 93 × 56	100 × 93 × 56

model	DR-100-24	DR-480-24
power supply size	100 W	480 W
input control voltage	100–240 V AC/3 A	100–240 V AC/5 A
heat output voltage	24 V DC/4.2 A	24 V DC/20 A
dimensions w × h × d (mm)	100 × 93 × 56	89 × 126 × 129



R-Box (for 12 V regulation)

- input voltage: 230 V/50 Hz
- output signal: 0 to 10 V/1 k Ω
- galvanically separated 4 kV AC – optocouplers
- degree of protection: IP 20
- installation on the DIN rail in the switchboard
- incorporates speed signal galvanic separator module
- operating ambient temperature: 0–40 °C
- dimensions w × h × d (mm) – 70 × 58 × 90



Installation box

- wall built-in
- used for the DC power supply source (source DR-60-12, DR-100-12 and DR-100-24) installation and the R-Box in cases where the installation in switchboard is not possible
- IP 40
- dimensions w × h × d (mm) – 258 × 318 × 72



Heating control elements (cooling) medium

Thermoelectric drive

- power supply voltage:
12 V regulation; 1.8 W
24 V regulation; 2 W
- CLOSED without power supply
- degree of protection: IP 54
- connection cable 2 × 0.75 mm², length 1 m
- closing/opening time < 3 min.



Shut-off valve

- straight or corner section (according to the order)
- dimension 1/2" G
- material – nickel-plated brass



Thermostatic head fluid with capillary

- regulation range +6.5 to +28 °C
- installation of the actuator into the wall
- length of capillary 5 m
- hysteresis: ≤ 0.6 °C



Preset stage	1	2	3	4	5	6	7	8	9
speed	1 1/4	1 1/2	1 3/4	2	2 1/2	3	3 1/2	4	Complete opening
Kv	0.14	0.20	0.31	0.43	0.60	0.79	1.00	1.20	1.35

Kv flow coefficient (m³/h)

Thermostatic valve

- straight or corner section (according to the order)
- with preset Kv value
- dimension 1/2" G
- connection dimension of the head M 30 × 1.5
- material – nickel-plated brass
- maximum operating pressure PN 10
- maximum operating temperature 90 °C



Preset stage	1	2	3	4	5	6
Kv ($\Delta t = 2K$)	0.10	0.20	0.30	0.40	0.50	0.60
Kvs	0.10	0.20	0.30	0.40	0.57	0.80

Kv flow coefficient (m³/h)
Kvs maximum flow (m³/h)
 $\Delta t = 2K$ valve proportionality band (K)

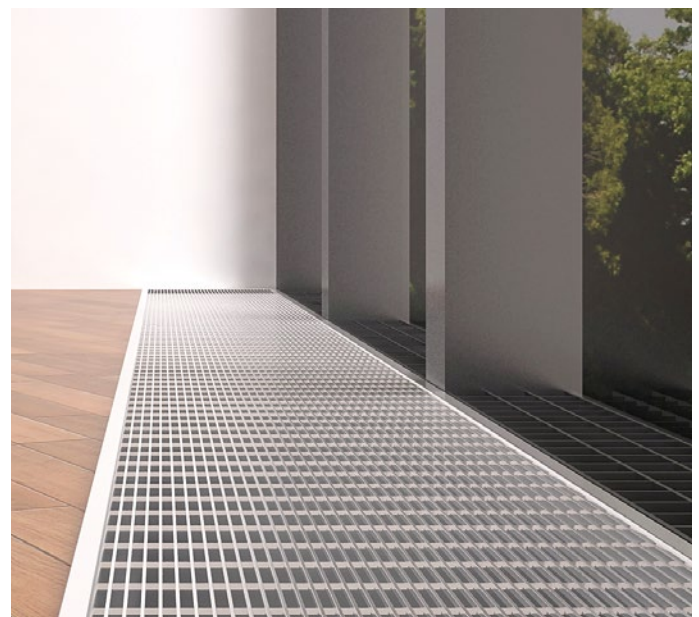

Connection diagram of convectors in the variant with heating media valves.

Connection diagram for 12 V DC regulation of convectors (KORAFLEX FV, KORAFLEX FV InPool, KORAFLEX FW, KORAFLEX FI, KORALINE LV, KORAWALL WI)

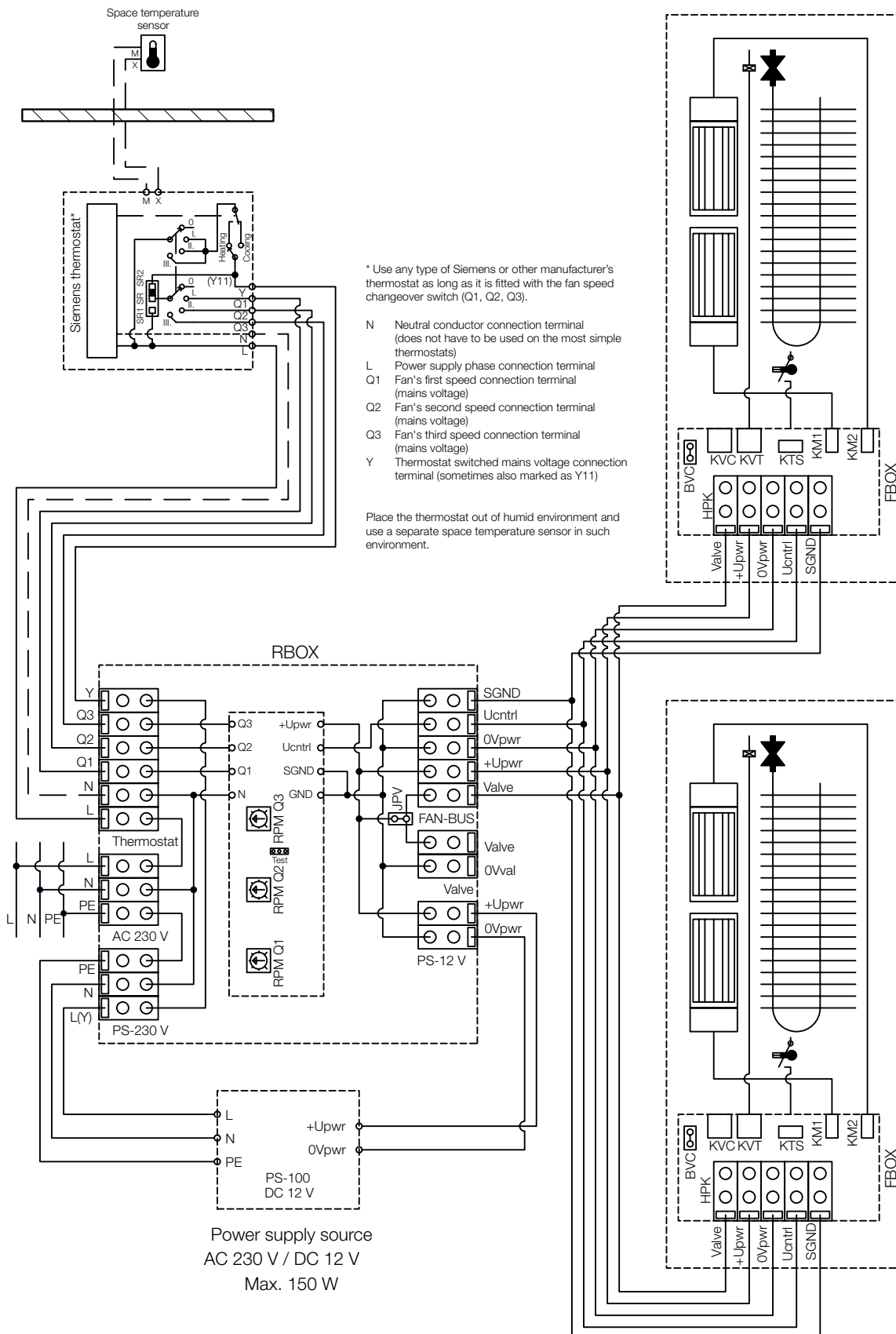

Connection diagram for **12 V and 24 V DC regulation of convectors**
 (KORAFLEX FV, KORAFLEX FV InPool, KORAFLEX FW, KORAFLEX FI, KORALINE LV,
 KORAWALL WI) – **BMS control (Building Management System)**

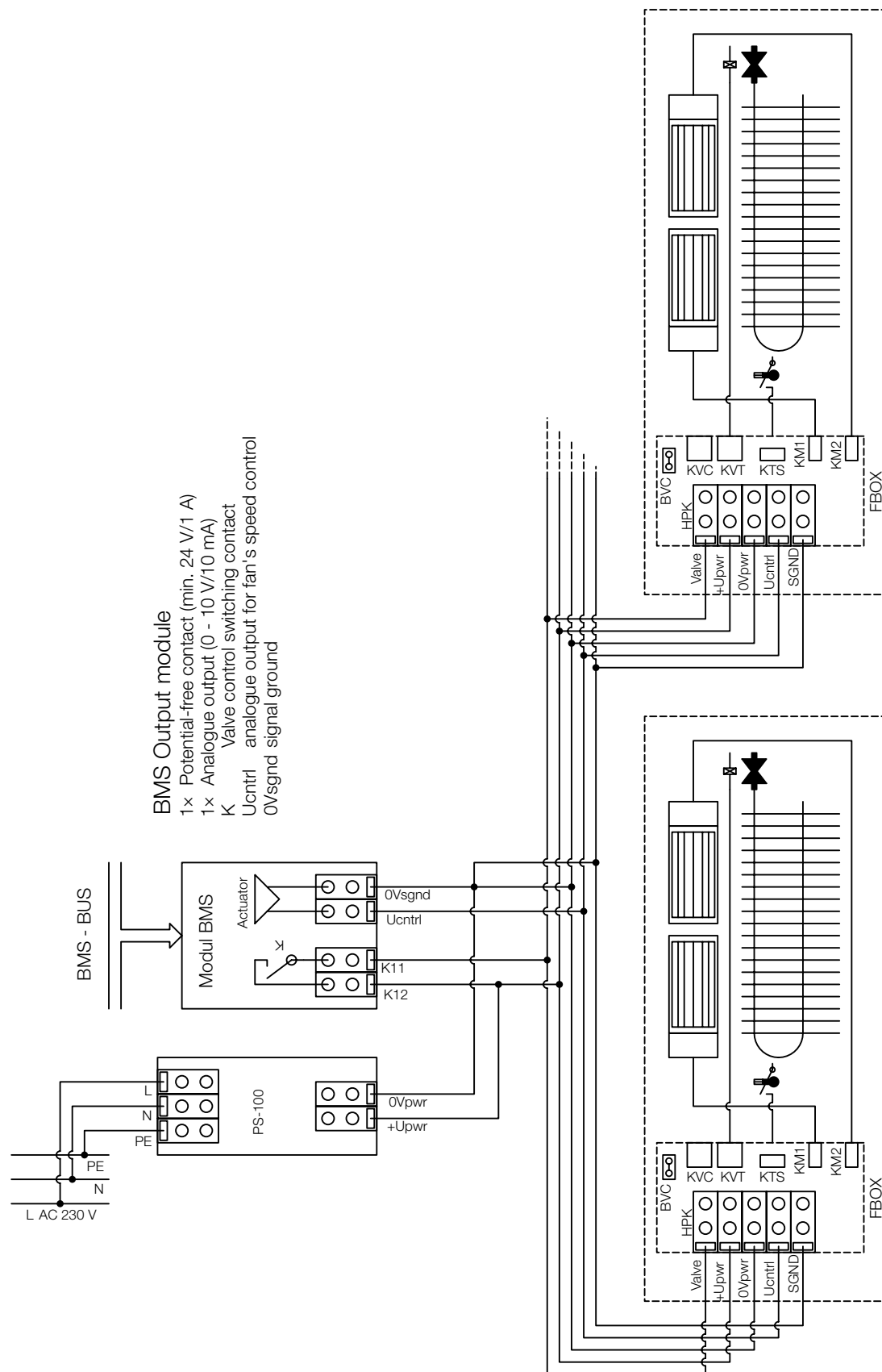

Connection diagram for **12 V DC regulation of convectors**
 (KORAFLEX FV, KORAFLEX FV InPool, KORAFLEX FW, KORAFLEX FI,
 KORALINE LV, KORAWALL WI) **with multiple DC voltage supply sources**

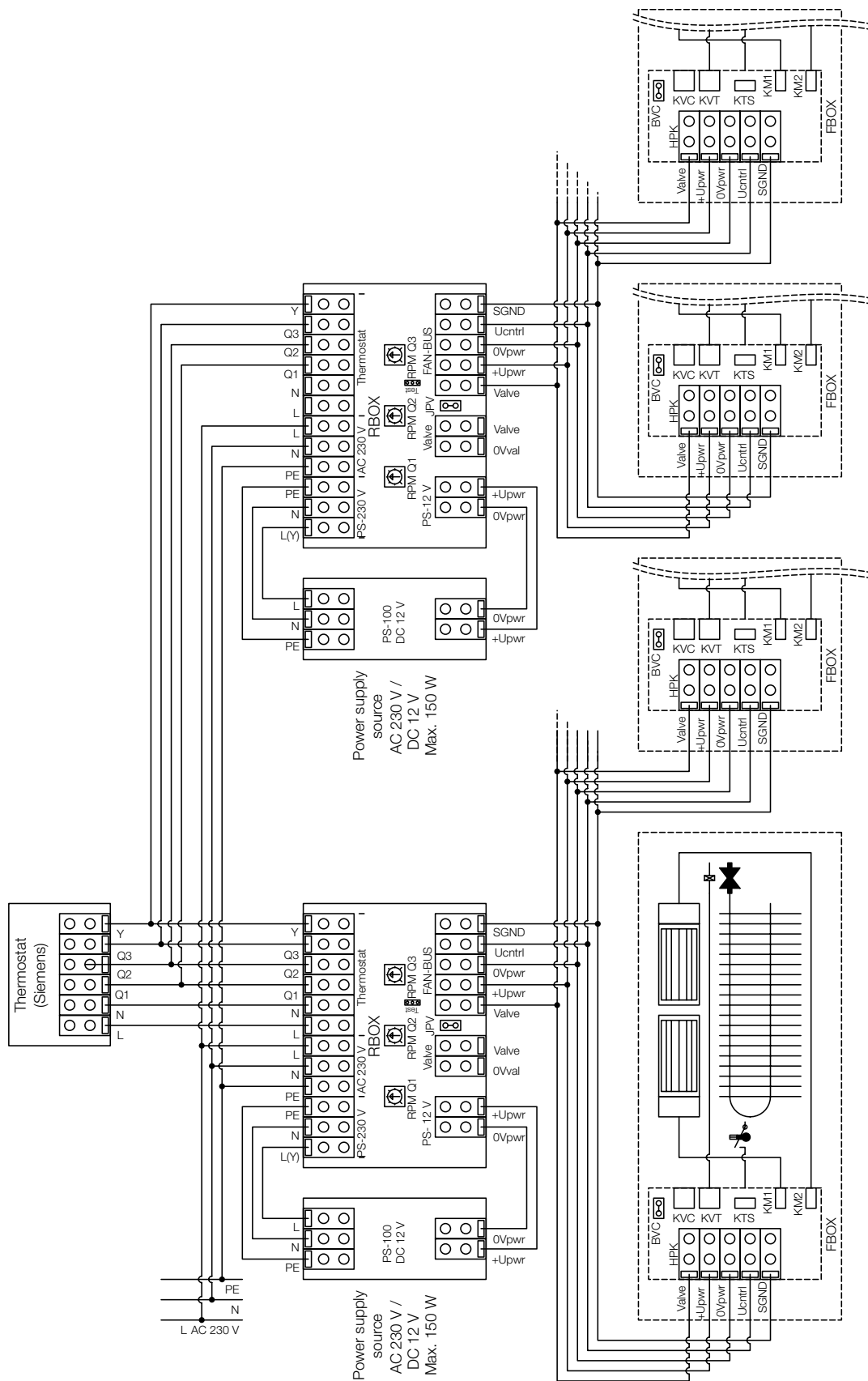

Connection diagram for **24 V DC regulation of convectors**
 (KORAFLEX FV, KORAFLEX FV InPool, KORAFLEX FI, KORALINE LV,
 KORAWALL WI), **two-pipe system**

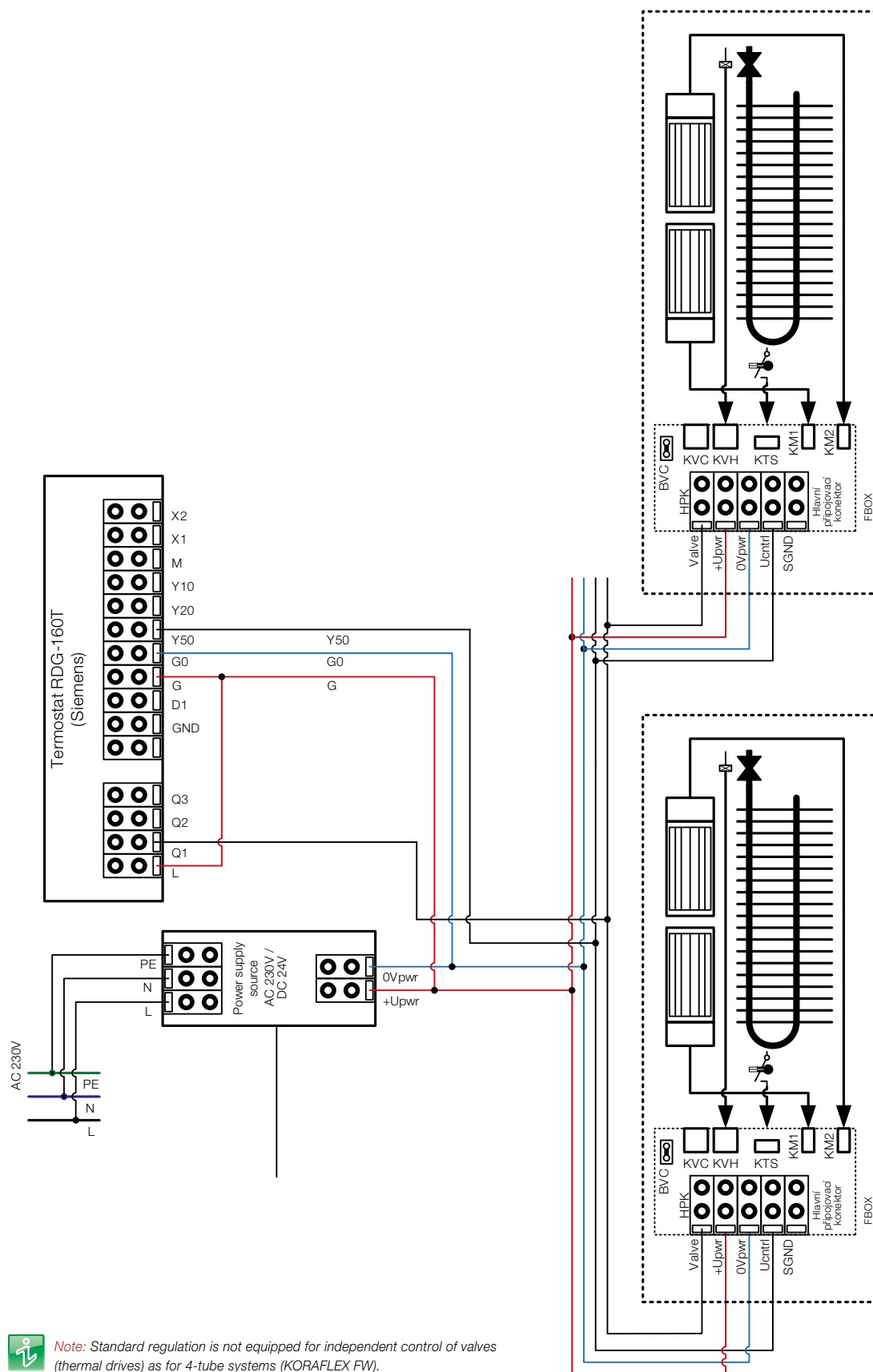

Note: Standard regulation is not equipped for independent control of valves (thermal drives) as for 4-tube systems (KORAFLEX FW).

Example of the design calculation of the output of the DC power supply

The electrical input must be calculated in terms of regulation so that the correct size of the DC power supply source is selected. The total input power will be a sum of all input power of the convectors with forced convection which will be controlled through one thermostat.

For example:

According to the project we have the following fan-coil unit types:

2 pcs of KORAFLEX FV 160/9/28 – we find the input power of 12 W in the table

1 pc of KORALINE LV 240/15/18 – we find the input power of 22.5 W in the table

2 pcs of KORAWALL WI 100/45/11 – we find the input power of 8 W in the table

(optionally 4 pieces of thermoelectric drives –

$4 \times 1.8 \text{ W} = 7.2 \text{ W}$)

Total power input:

$12 + 12 + 22.5 + 8 + 8 = 62.5 \text{ W}$

Select source rated 100 W.

		100	
0	23.4	31.7	3
		8/12-24	
Off	1	2	
0	291	407	5

Acoustics

Apart from the input power one of the main parameters is the noise level of the fan convectors. Manufacturer develops and designs its products so that they do not exceed under any circumstances the specified noise levels laid down by the health standards for this type of equipment. Generally this limit is 30 dB (A) of the sound power that means that the product does not exceed this limit at the minimum speed. Products marked with the logo OC  has been optimized for the noise/performance ratio. Manufacturer uses in its products always the most advanced technology, as well as in the case of the fans. The used fans are equipped with a patented disc engine with permanent magnets. Among the main benefits is belong a significant noise reduction and a low energy consumption compared to commercially available fans with the rotor and stator.

Manufacturer indicates in its materials a parameter to assess the noise level the acoustic pressure L_p (A) measured at 1 m from the source. The measurements were carried out by an authorised test laboratory.

The values of the sound power are available on request.

Acoustic pressure

The acoustic pressure is a change of the air pressure generated by a source of noise. Such pressure fluctuations are measured in N/m^2 and expressed by the symbol "p". The acoustic pressure represents the measure of volume. It depends on the distance between the source of the noise and the place of the measurement and also on the characteristics of the space.

Sound power

The energy converted by a piece of equipment (the source of sound) to sound is referred to the sound power. This sound power is brought to the air in the form of pressure fluctuations. The sound power is not a directly measurable quantity. It is determined by integrating of the acoustic pressure in the form of a hemisphere or a sphere around the sound source.

The acoustic pressure is on this basis a quantity that is independent of space and distance. It is used for all further calculations. On request, will provide values of sound power of its OC products. Although the acoustic pressure level and sound power level use the same unit (dB), they are two different physical quantities. The sound power level is the sound generated at the sound source (energy introduced to the space) while the acoustic pressure level is the sound registered at a certain distance from the sound source. This means that the sound power level is generally higher than the acoustic pressure level.

Case with noise-absorbing foil

For further noise reduction, it is possible to order a convector case fitted with noise-absorbing foil. The foil reduces the noisiness by 1 to 3 dB depending on the type, length and speed of the convector.

Anti-noise foil

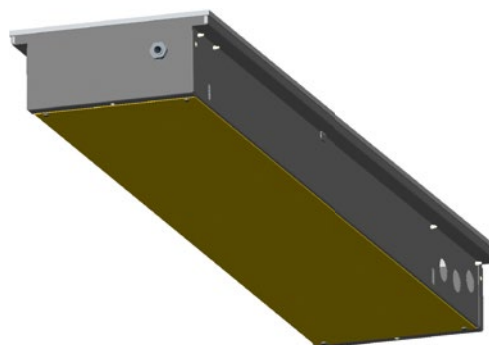

Anti-noise foil – cross section

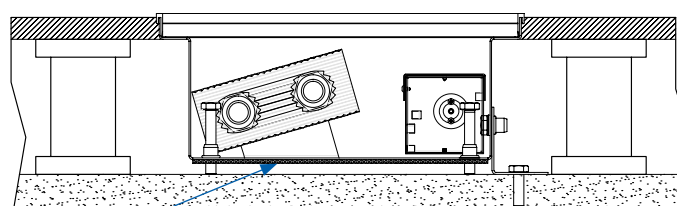

acoustically absorbent sheet

Graphic representation of the noisiness level of OC convectors



Acoustic pressure at the distance of 1 m from the convector with forced convection of \varnothing 30 mm.

For convectors type KORAFLEX FV 8/16 a 8/28.

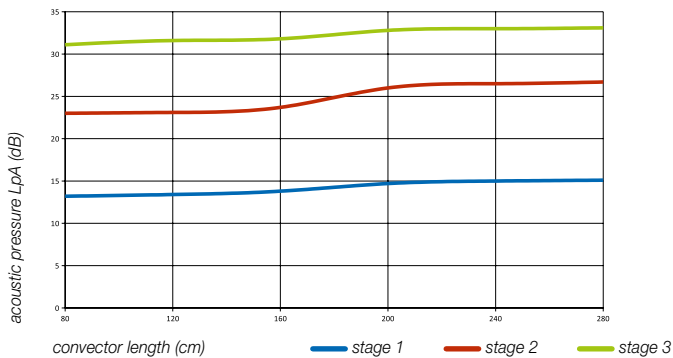

Acoustic pressure at the distance of 1 m from the convector with forced convection of \varnothing 40 mm.

For convectors type KORAFLEX FV 9/28, 11/20, 11/28, 11/34, 11/42, KORAFLEX FI 11/20, KORAFLEX FV InPool 13/34.

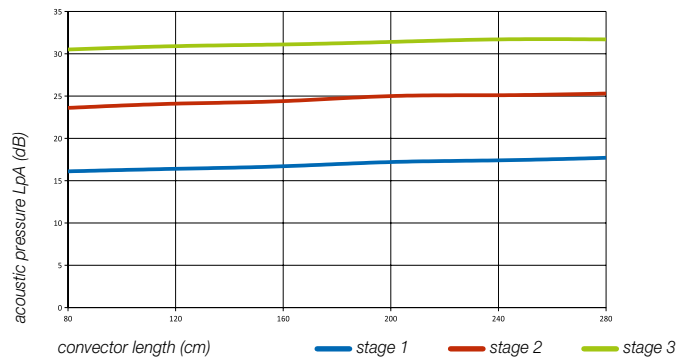

Acoustic pressure at the distance of 1 m from the convector with forced convection of \varnothing 30 mm.

For convector type KORALINE LV 15/11.

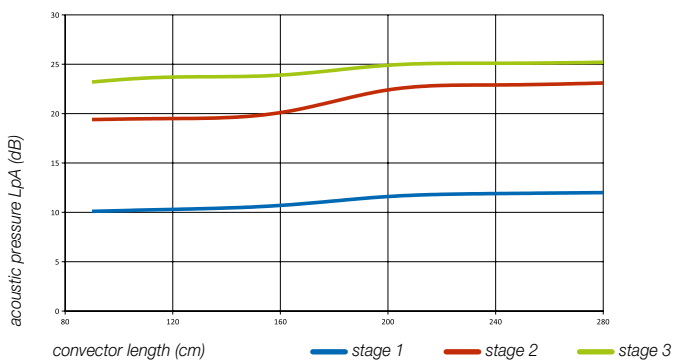

Acoustic pressure at the distance of 1 m from the convector with forced convection of \varnothing 40 mm.

For convectors type KORALINE LV 15/18 a 15/24.

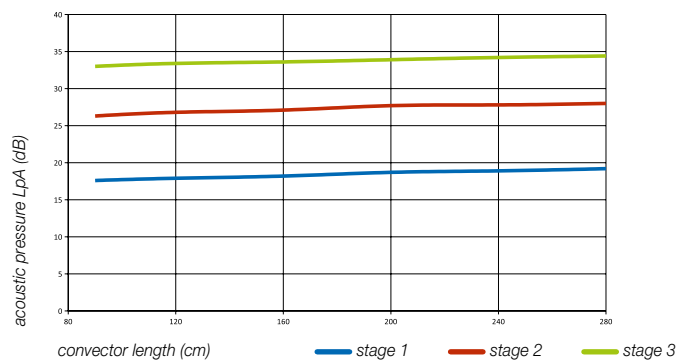

Acoustic pressure at the distance of 1 m from the convector with forced convection of \varnothing 60 mm.

For convectors types KORAFLEX FI 13/34, KORAFLEX FW 13/34.

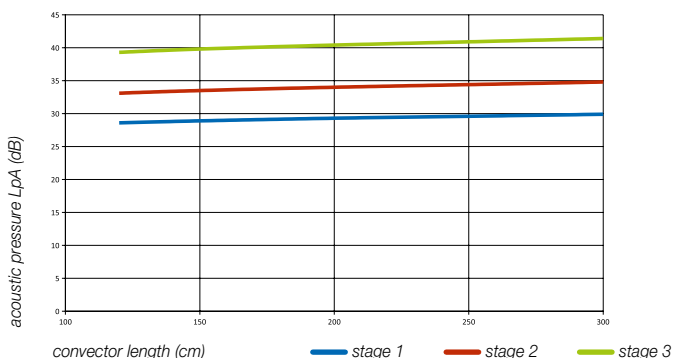

Acoustic pressure at the distance of 1 m from the convector with forced convection of \varnothing 60 mm.

For convector type KORAWALL WI 45/11.

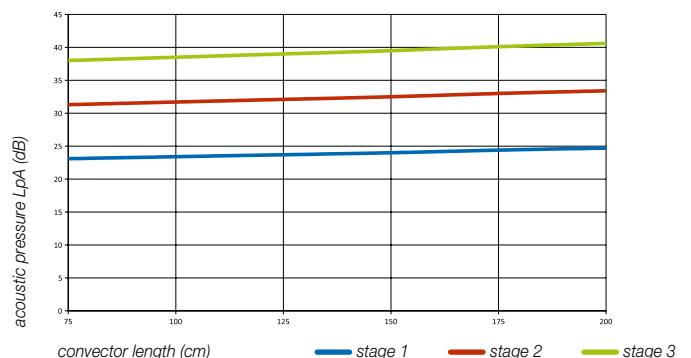

Volume of air per 1 m of fan-cooled heat exchanger length (m^3/h)

fan diameter	stage 1 speed	stage 2 speed	stage 3 speed
30 mm	135	180	225
40 mm	180	240	300
60 mm	325	437	512

Pressure losses of convectors

KORAFLEX FV 8/16

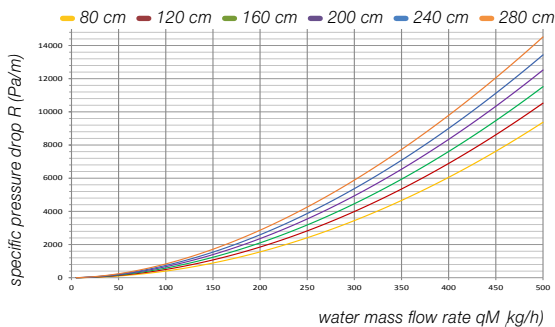

KORAFLEX FK 9/16, 11/16 KORABASE 10

KORABASE 10

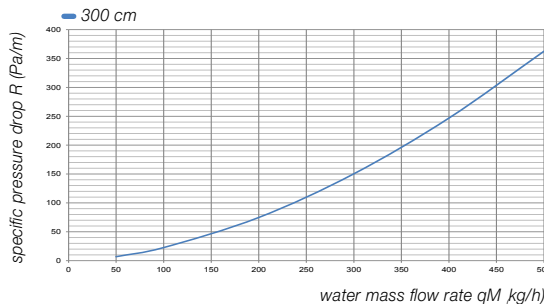

KORAFLEX FK 9/20, 9/28, 11/20, 11/28 KORALINE 9/18 and 9/24, KORABASE 20 KORAFLEX FV 8/28, 9/28, 11/28 KORAFLEX FV InPool 13/34

KORABASE 20

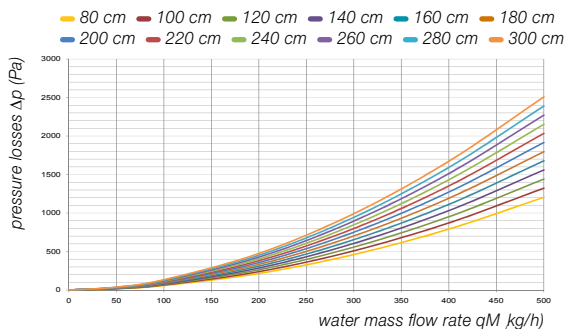

KORAFLEX FK 9/34 and 11/34 KORAFLEX FV 11/34, KORABASE 30

KORABASE 30

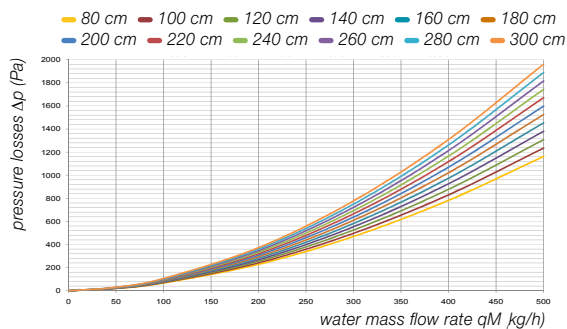

KORAFLEX FK 9/42, 11/42 KORAFLEX FV 11/42

KORABASE 40

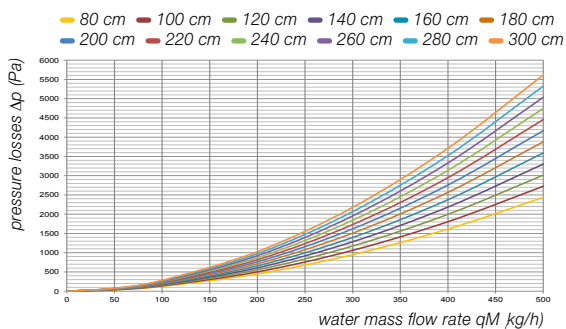

KORAFLEX FK 15/28, 19/28, 30/28, 45/28 KORALINE LK 15/18, 30/18, 45/18, 60/18 KORABASE 22

KORABASE 22

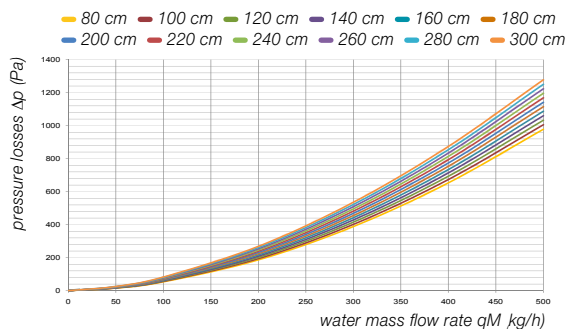

KORAFLEX FK 15/34, 19/34, 30/42, 45/42 KORALINE LK 15/24, 30/24, 45/24, 60/24 KORALINE LD, KORABASE 33

KORABASE 33

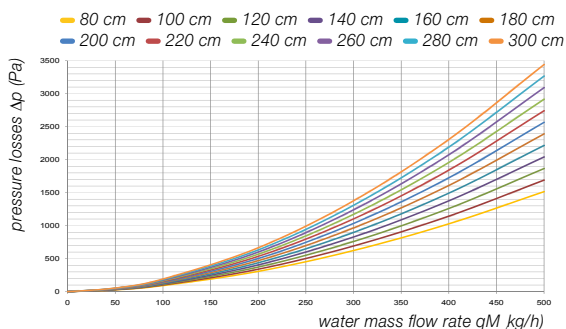



KORAFLEX FK 15/42, 19/42

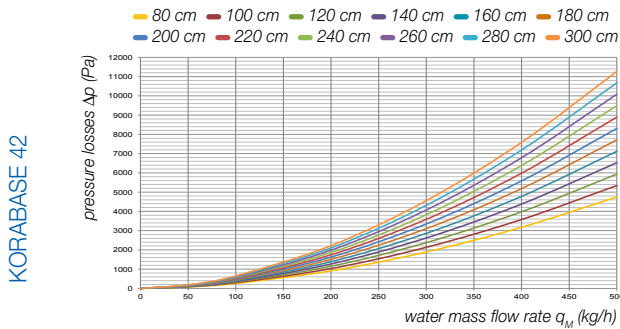

KORAWALL WK 45/6, 60/6

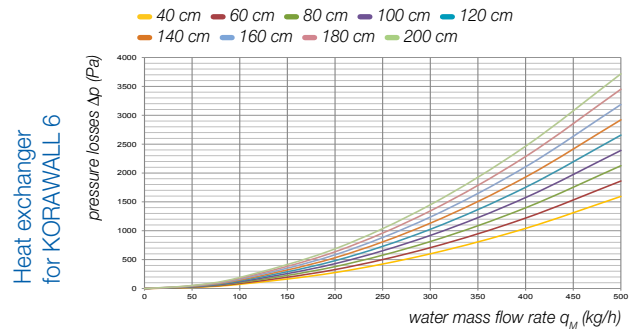

KORAWALL WK 45/12, 60/12

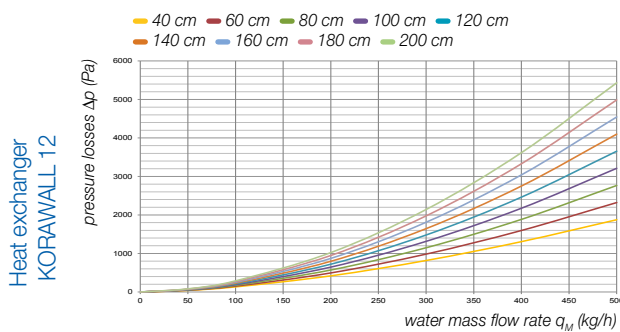

KORAWALL WI 45/11

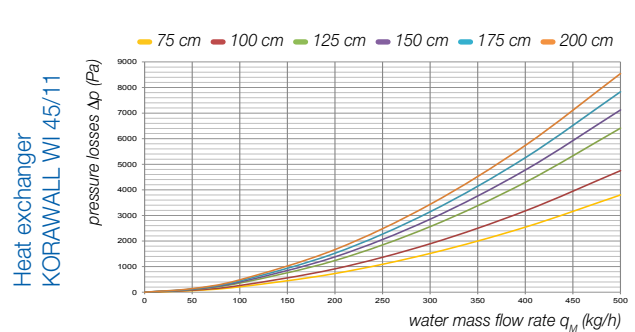

KORAFLEX FV 11/20 and FI 11/20

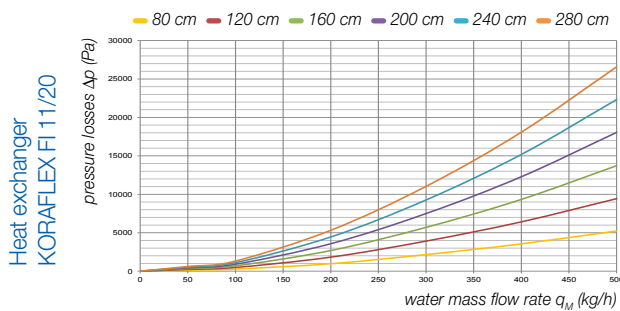

KORAFLEX FI 13/34

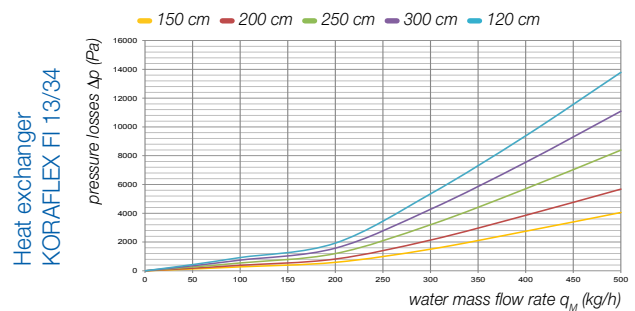

KORAFLEX FW 13/34

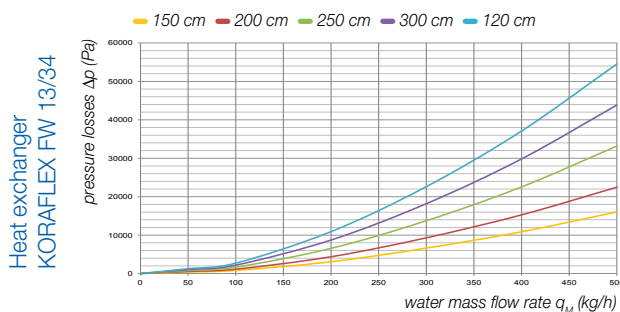

Examples of conversion to a variant temperature difference

$$\Delta t = (t_1 + t_2)/2 - t_i$$

Where: t_1 is the input water temperature (°C)
 t_2 is the output water temperature (°C)
 t_i is the air temperature (°C)
 Δt is the cooling of water (K)

The resistance coefficient is valid for both 1/2" connections. You will find the kt factor in the table of correction factors of the particular element.

Entered: KORABASE 22/140 heating element

Operating temperature conditions: 75/65/20 °C

$Q_n = 1\ 198\ \text{W}$ should be converted to the temperature difference $\Delta t = 40\ \text{K}$

$Q = Q_n \times \text{factor kt} = 1\ 198 \times 0.748 = 896\ \text{W}$

Entered: KORAWALL WK 140/60/6 heating element

Operating temperature conditions: 75/65/20 °C

$Q_n = 1\ 018\ \text{W}$ should be converted to the temperature difference $\Delta t = 30\ \text{K}$

$Q = Q_n \times \text{factor kt} = 1\ 018 \times 0.515 = 525\ \text{W}$

* Pressure losses of KORALINE LV are available on request.

General information about products

Heating elements are produced using the state-of-the-art technologies. Most production operations are executed on CNC machines. The surface of elements is treated with powder coating of epoxy-polystyrene paints on an environment-friendly line. In-house production of high performance heat exchangers (copper pipe, aluminium lamellas) guarantees high quality and wide variety of products offered. To achieve an "invisible" impression you can order a black coated exchanger.

The case supplied as the standard is made of a black coated galvanised steel sheet. For use in wet environments you can order a case of a high corrosion resistance stainless steel. Thanks to our advanced production technology we are able to produce atypical dimensions, including angled and arc convectors' designs.

The shortest possible delivery periods are offered, from 3 to 10 working days. Guaranteed warranty and after-warranty service.



Universal regulation



Natural convection



Heating



Forced convection



Quiet operation



Swimming pools design



Cooling



Dry-cooling



Environmentally friendly



Minimal Energy consumption



Higher performance



Information

Transport and storage instruction

During transport the elements must be handled with extreme care and must be secured against motion and damage. The transport and storage area must be dry and protected from climatic influences.

Maintenance

The convectors must be kept clean and especially before the heating season any dirt and dust should be removed from the convector. The fan convectors must be checked if the fans are not mechanically blocked (by fallen objects, a layer of dust, etc.).

Quality

Manufacturer is a holder of the certified quality management system as per ISO 9001:2008. The products are manufactured and tested according to EN 422. By using CE mark the producer confirms that the convectors are in conformity with the characteristics stated in the Declaration of Performance issued in conformity with the directive of EP and the Council (EU) No. 305/2011. This conformity was approved by the notified body No.1015, Strojírenský zkušební ústav, s.p. Brno.



Proven heating and cooling performances



Warranties

The products are subject to 2-year warranty. 10-year warranty is provided for the tightness of the heat exchanger. Full service and warranty terms and conditions are available on demand.

Manufacturer KORADO, a.s. is not responsible for damage caused by improper installation, or damages arising from poor electrical or thermal installations (such as fluctuating voltage or hydraulic pressure which deviates significantly from normal values).

Manufacturer reserves the right to change technical specifications without a prior notice.



A series of horizontal blue lines spanning the width of the page, intended for writing notes.

A series of horizontal blue lines on the left side of the page, intended for writing notes.





A series of horizontal blue lines spanning the width of the page, intended for writing notes.

A series of horizontal blue lines on the left side of the page, continuing the note-taking area.



Notes

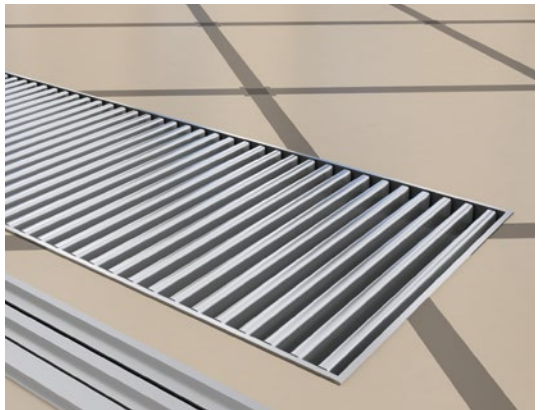

References



Main Point Karlin, Prague 8



Triplex - residential building, Karlovy Vary



Technical University, Liberec



Conference centre Harfa, Ireland

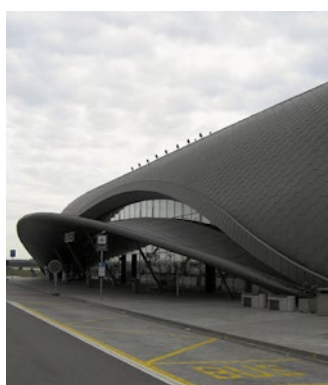

Airport, Brno



Administrative building Trinity, Brno



Headquarters of the Celsis Company, Lithuania



Ještěd Hotel, Liberec

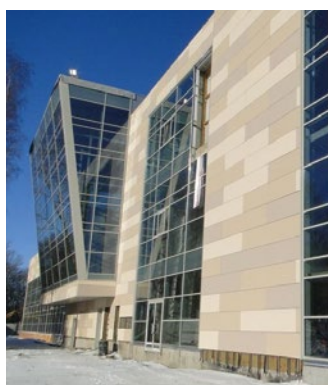

SBK Spartak S. Peterburg, Russia



City Green Court, Prague



Administrative building, Denmark



Opera House, Denmark

We shall be pleased to extend the overview of interesting references also by your project!



KORADO, a.s.
Bří Hubálků 869
560 02 Česká Třebová
Czech Republic

e-mail: info@korado.cz
www.korado.com

06/16.851.1 EN

