

# KOOLAIR

## series

# DGV

Variable geometry  
diffusers

ISO 9001

BUREAU VERITAS  
Certification

Sistema de Gestión



[www.koolair.com](http://www.koolair.com)



## CONTENTS

DGV variable geometry diffuser	2
General information	3
Quick selection charts	5
Selection example	6
Selection charts	11

## DGV variable geometry diffuser



### Description

DGV round, variable-geometry diffuser constructed of steel plate. The standard finish is RAL 9010 white paint. By special order, the diffuser can be painted in any RAL colour.

### Operation

The DGV diffuser is composed of two concentric modules. The inner module is moveable, and can be moved manually or by a servo drive. This sliding inner module was designed such that, when moved, it simply and efficiently changes the direction of the outlet airflow. The flow direction may be horizontal (for cold air) or vertical (for hot air) as well as any intermediate position, allowing the operation to be precisely adjusted to meet the necessary requirements.

### Applications

The DGV variable-geometry diffusers are perfectly adaptable to industrial applications as well as areas requiring more comfortable conditions, and can be installed at heights of up to 15 metres (in drop and suspended ceilings). The variation in the air direction for cold or hot air (either manually or automatically with a servo drive or thermostatically adjustable) makes these units particularly suitable for the air conditioning of large spaces such as large vestibules, sport centres, industrial warehouses, airports, entertainment areas, etc.

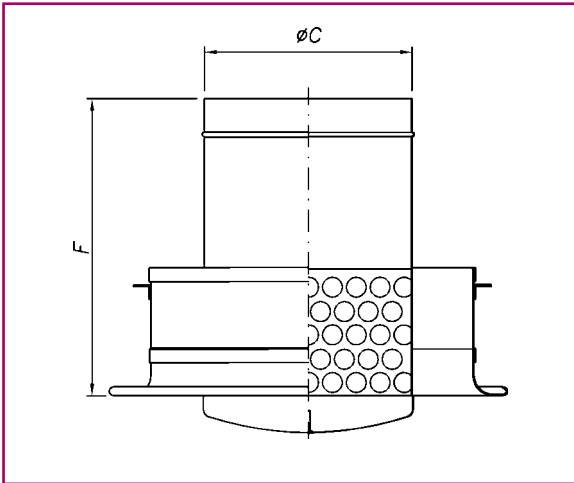

DIMENSIONS IN mm.		
MODEL	Ø C	F
250	249	440
315	314	440
400	399	440
500	499	440
630	629	580

### Dimensions and operation

The attached table lists the overall dimensions of the diffusers. The overall dimensions of diffuser-plenum box assembly are also shown on page 4.

### Identification

The code allows the various sizes and models of the DGV diffusers to be identified.

The servo drive can be accessed through the diffuser, preventing the need for access through the drop ceiling. The plenum boxes contains several suspension tabs. By special order, the plenum boxes contain internal insulation.

<b>DGV</b>	Round, variable-geometry diffuser series.
<b>P</b>	With plenum box plus manual.
-	Without plenum box.
<b>M. MOT</b>	With motor-driven operation.
<b>M. MAN</b>	With manual operation.
<b>TR</b>	Thermostatically adjustable.
<b>Size</b>	From 250 to 630, according to table.

## General information

- The DGV-type diffusers have a variable geometry and were designed to meet the air conditioning needs of areas which, depending on the thermal loads during the various seasons of the year, require cold or hot isothermal air. By changing the positioning of an internal device, the direction of the outlet airflow is changed, thereby achieving a horizontal or vertical throw, as well as adjustment within several intermediate positions.

- The DGV-type diffuser was designed by the Research & Development Department of KOOLAIR, S.A., and tested and calibrated in our own Distribution and Acoustic Laboratory, which is equipped with the most advanced control and measurement systems. The most advanced theories on air diffusion in rooms have been used in its application, based on experiments and studies performed at the KOOLAIR laboratory in Spain.

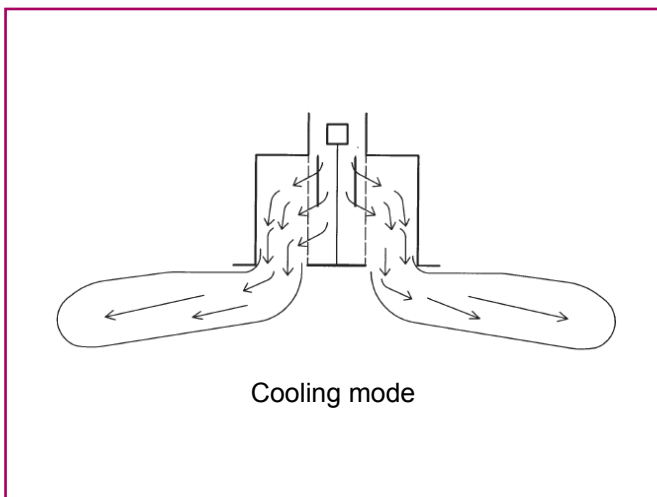
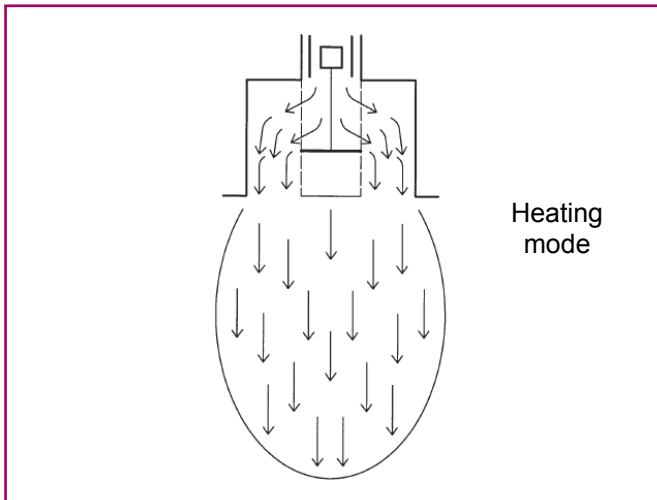

## Operating recommendations

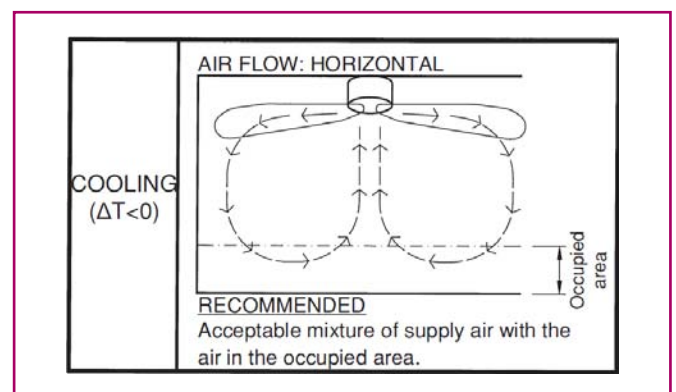
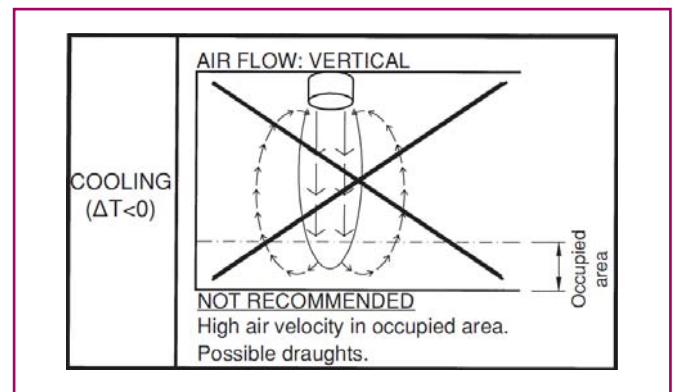
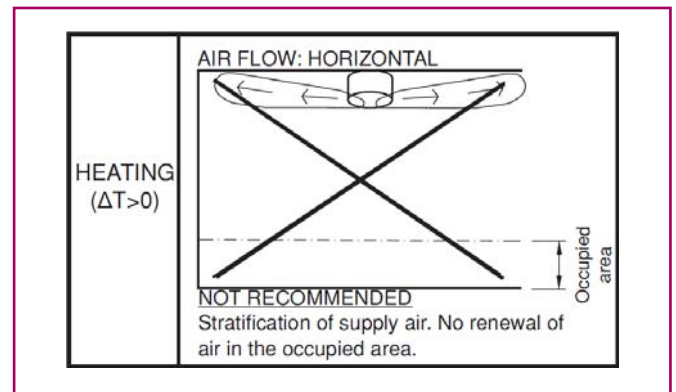
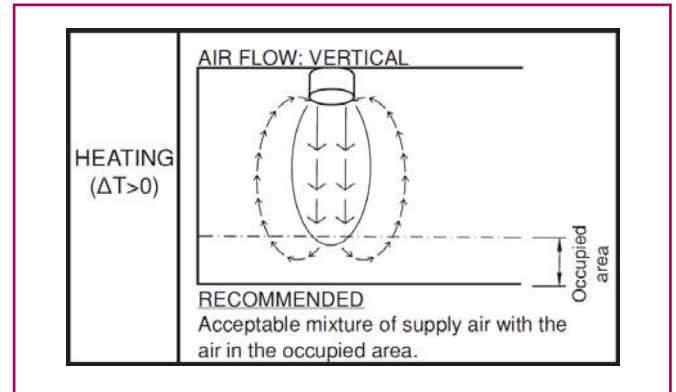

**Photographs of DGV diffuser tests in the R&D Laboratory of KOOLAIR S.A.**

**Plenum box for "DGV" diffuser (dimensions)**

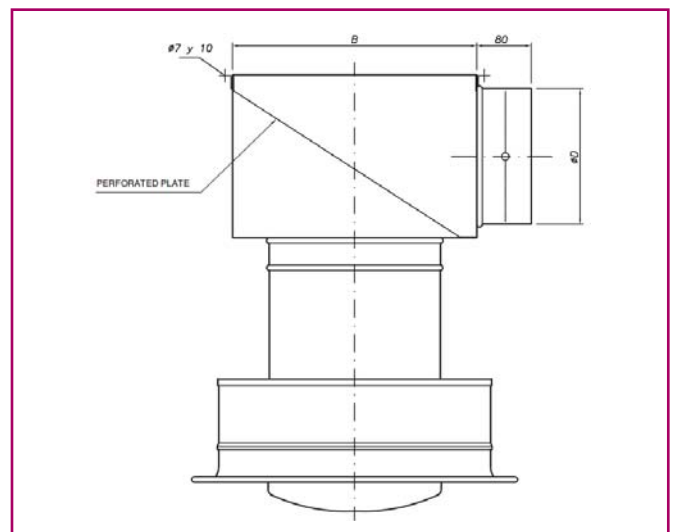
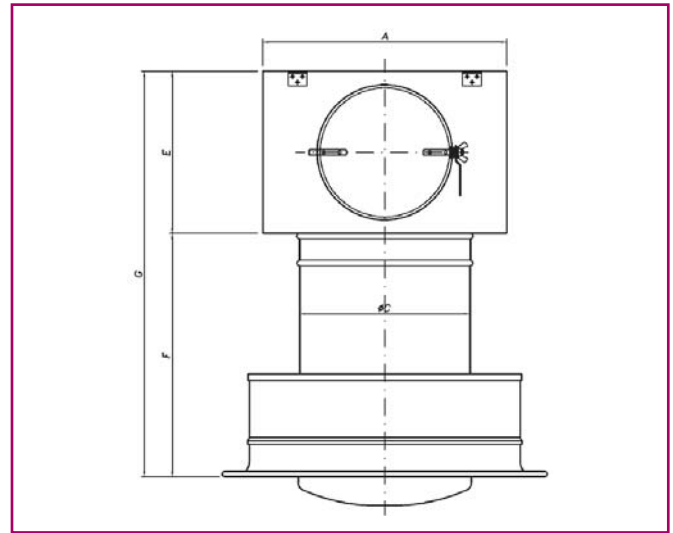

DIMENSIONS IN mm							
MOD.	A	B	E	Ø D	Ø C	F	G
250	350	350	300	250	250	440	740
315	450	450	400	315	315	440	840
400	550	550	450	355	400	440	890
500	650	650	500	400	500	440	940
630	800	800	600	500	630	580	1200

## Selection

### 1) DGV quick selection chart

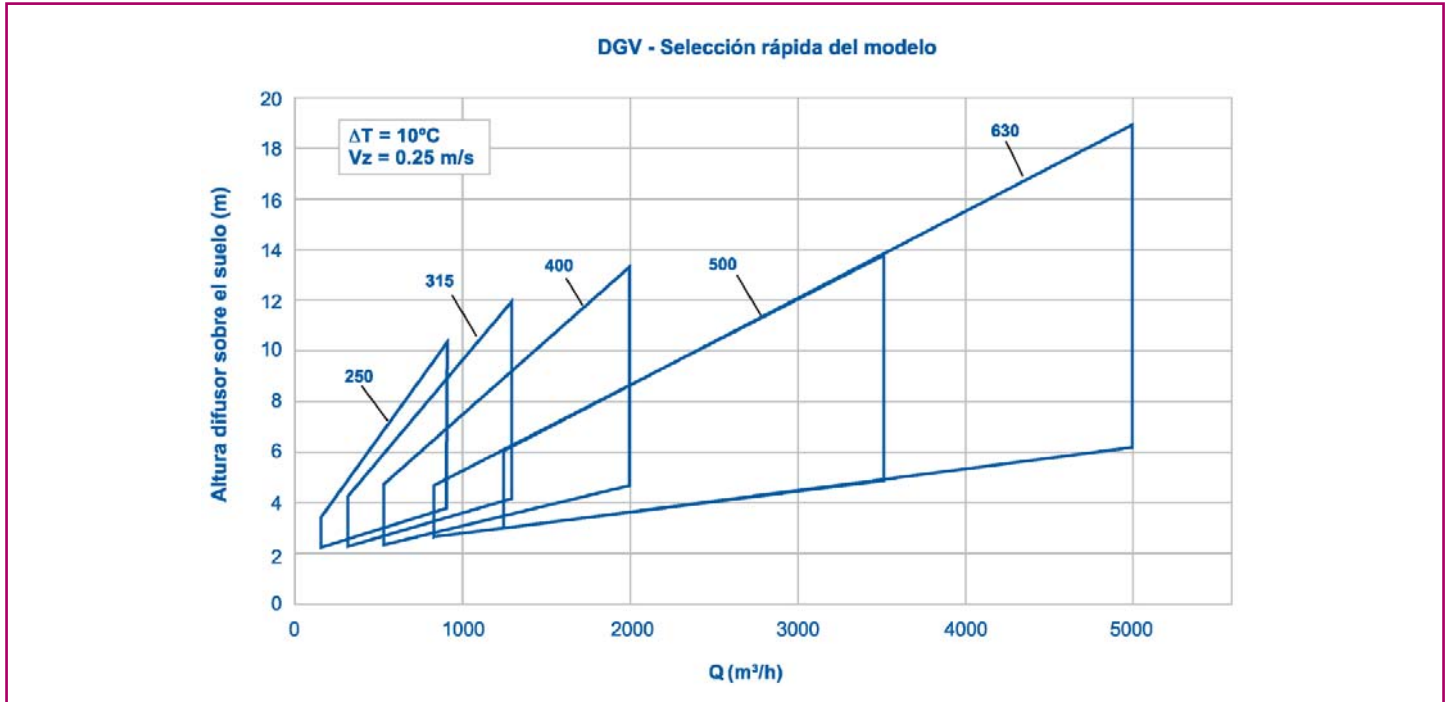

### 2) DGV noise level and pressure drop chart

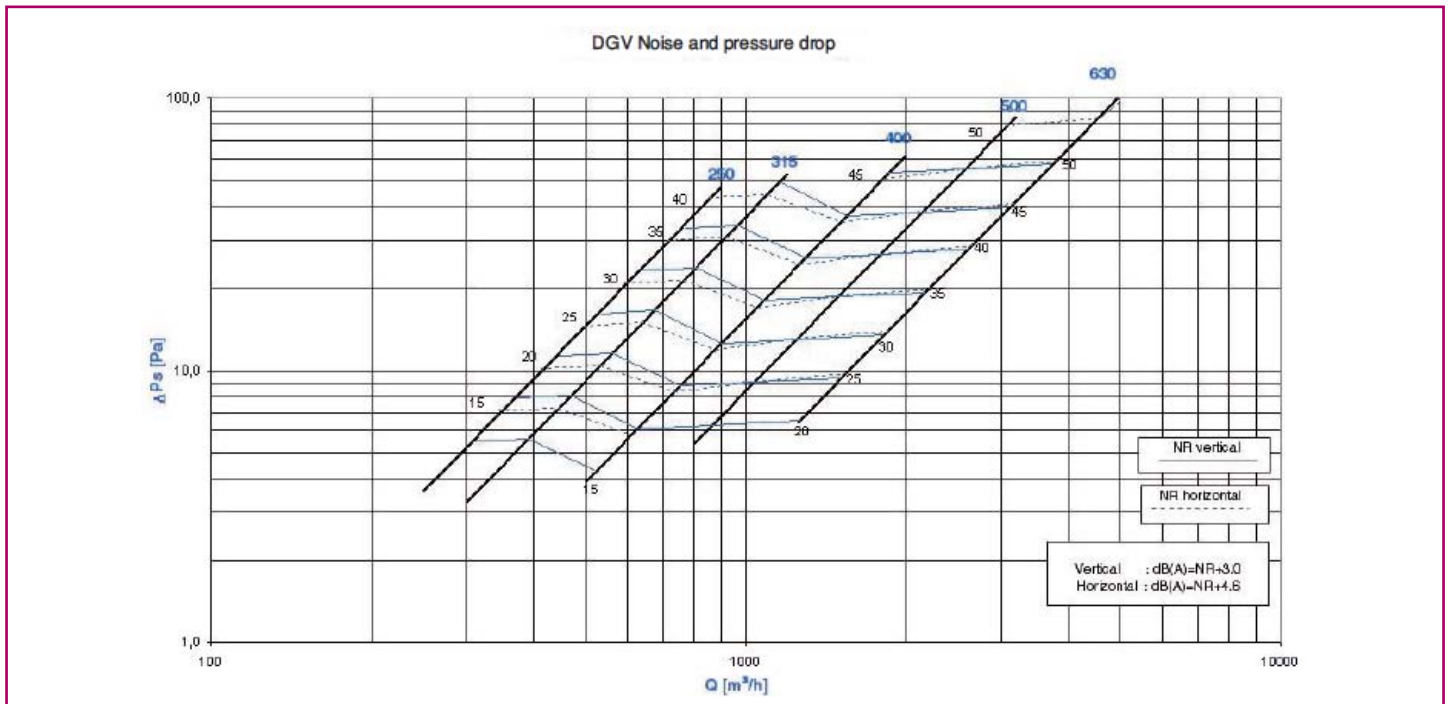

## Selection in a sample project

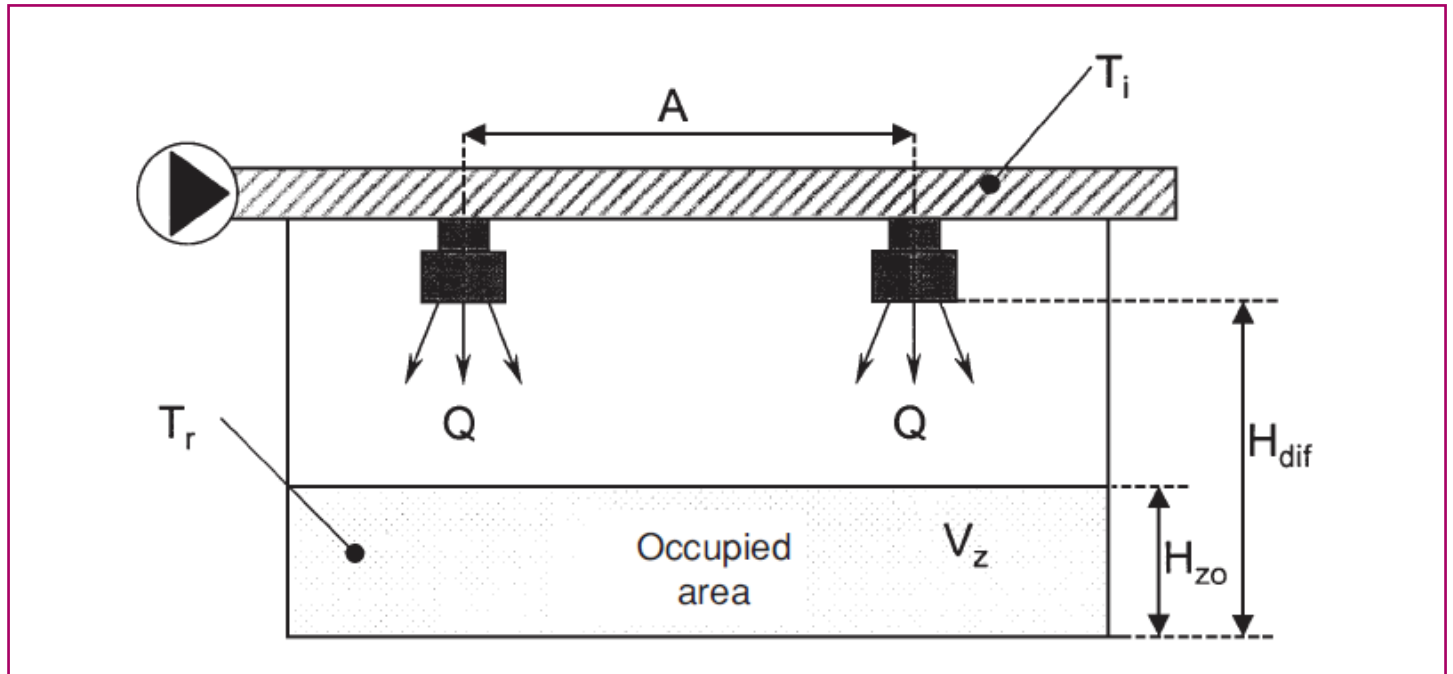

### Conditions

- $H_{dif} = 6.0 \text{ m}$
- $H_{zo} = 1.8 \text{ m}$
- $A = 5 \text{ m}$
- $Q = 800 \text{ m}^3/\text{h}$
- $T_i = 35^\circ\text{C}$
- $\Delta T = 15^\circ\text{C}$
- $T_r = 20^\circ\text{C}$
- $L_w < 40 \text{ dB (A)}$
- $P < 30 \text{ Pa}$
- $V_z = 0.25 \text{ m/s}$

### Symbols

- $H_{dif}$  = Distance from the supply mouth of the diffuser to the floor.
- $H_{zo}$  = Height of occupied area.
- $A$  = Distance between diffuser axes.
- $Q$  = Air flow in each diffuser.
- $T_i$  = Air supply temperature.
- $T_r$  = Room temperature.
- $\Delta T$  = Difference between supply and room temperature.
- $L_w$  = Sound power.
- $P$  = Pressure drop.
- $V_z$  = Maximum velocity in occupied area.

The above data are used for the selection, following the steps indicated below:

## Step 1.

### Quick selection tips for the model

Based on the flow rate and the distance,  $H_{diff}$ , from the diffuser supply outlet to the floor, the 250 or 315 models can be chosen.

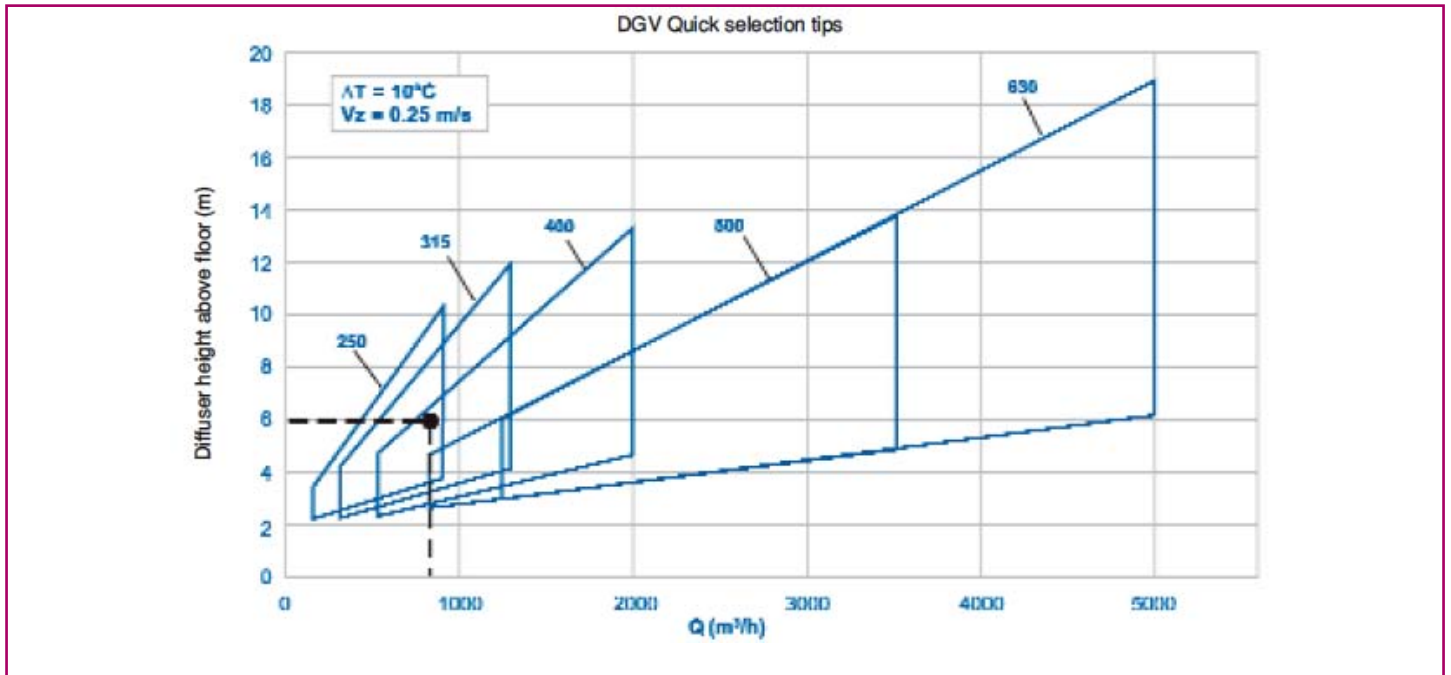

## Step 2.

### Verification by noise level and pressure drop.

The data are obtained from the flow rate and the diffuser model.

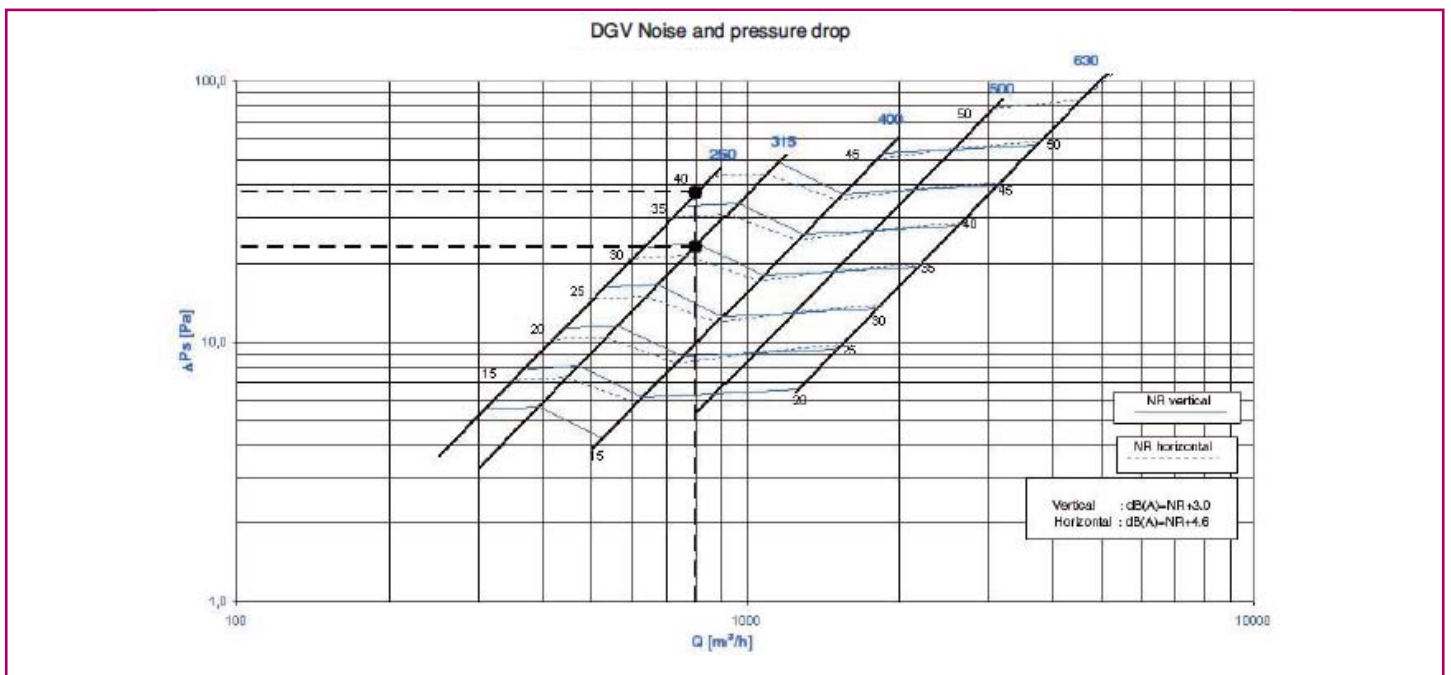



### Comparison

Thus, the charts indicate that the selected diffuser is DGV 315.

### Step 3.

#### Determination of the temperature correction factor (C<sub>y</sub>).

It is necessary to know if the diffuser throw is within the operating limits. The next step (n°4), is used to determine if the diffuser (in terms of throw) meets the needs required. This is determined by the temperature difference  $\Delta T$  (°C) and the maximum velocity in the occupied area,  $V_z$  (m/s), both specified in the conditions of the selection in the sample project.

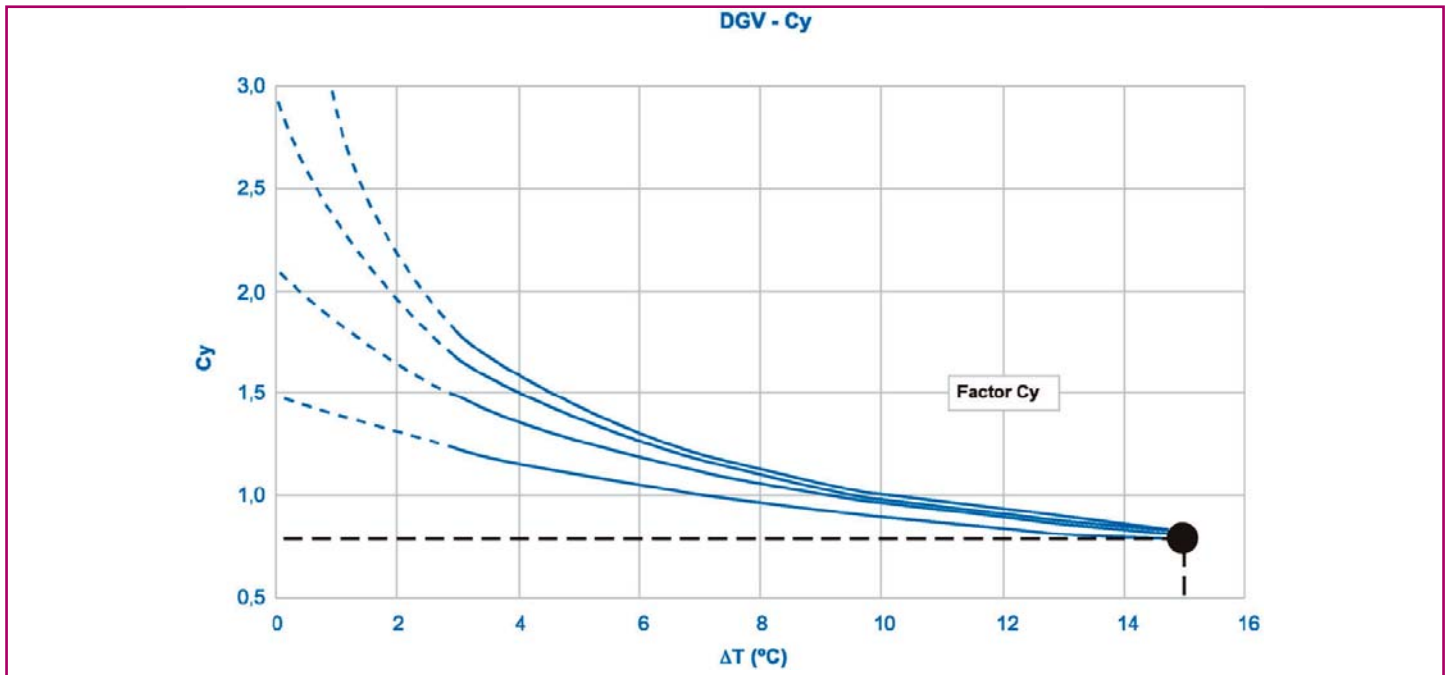

In this case, the factor «C<sub>y</sub>» = 0,8

### Step 4.

#### Verification of throw within the operating limits.

«A<sub>c</sub>», is obtained from the following equation:

$$A_c = [(H_{dif} - H_{z0}) / C_y] + H_{z0}$$

$$A_c = [(6 - 1,8) / 0,8] + 1,8 = 7,05 \text{ m}$$

Once the value of « $A_c$ », is determined, the following figure shows that the diffuser is within the operating limits (within the minimum and maximum lines). Likewise, it allows us to find the stroke (in mm) of the servo motor shaft that will keep the central core fixed at a convenient height, in order to ensure the performance for which it has been selected.

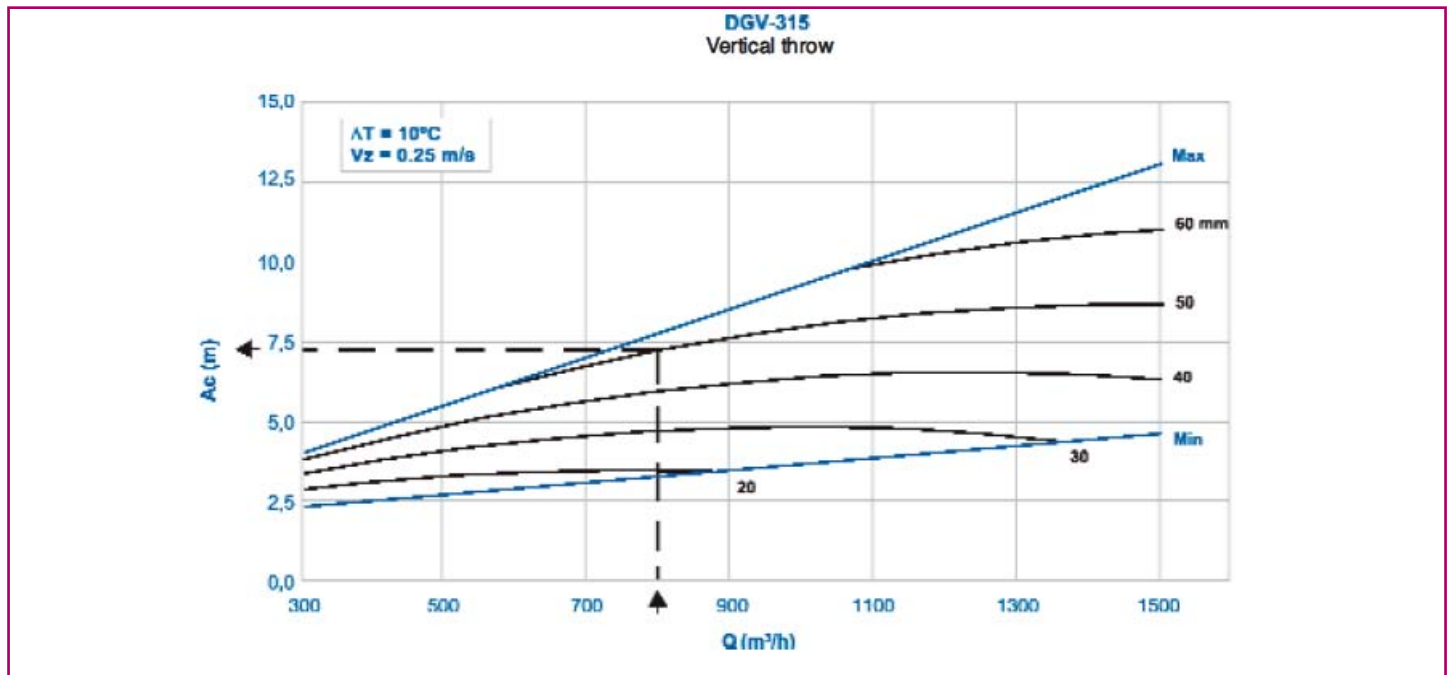

**Step 5.**  
**Determination of the correction factor to calculate the minimum distance between diffusers.**

This factor is known as  $C_a$ . and is obtained from the following chart, using the air flow per diffuser ( $Q \text{ m}^3/\text{h}$ ) and the maximum velocity in the occupied area ( $V_z \text{ m/s}$ ).

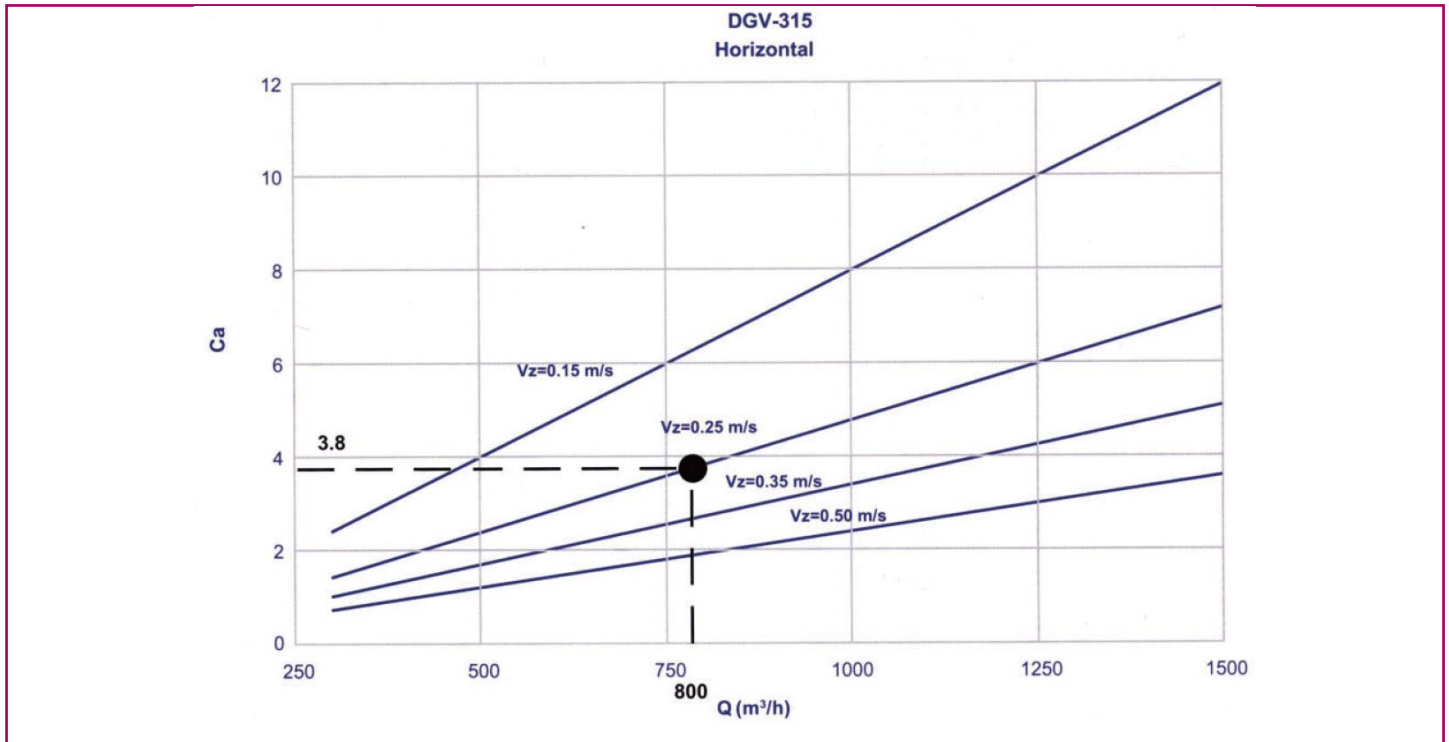

Where the factor  $C_a = 3.8$  from the following equation, yielding the following minimum distance,  $A$ , between diffusers:

$$A = C_a / (H_{\text{dif}} - H_{z_0})$$

$$A = 3,8 / (6 - 1,8)$$

$$A = 0,9 \text{ m}$$

As in the selection example, the projected distance between diffusers,  $A$ , is 5 m and the minimum distance recommended by the chart is 0.9 m. Therefore, the selection is correct.

## Conclusion

Diffuser selected: **DGV-315**

Air flow rate: 800 m<sup>3</sup>/h

Pressure loss: 24 Pa

Sound power: 38 dB (A)

Temperature difference  $\Delta T$ : 15°C

Maximum velocity in occupied area: 0,25 m/s.

Stroke of the electrical servo drive: 50 mm.

## Selection charts to determine the factor, $A_c$ (operating limits)

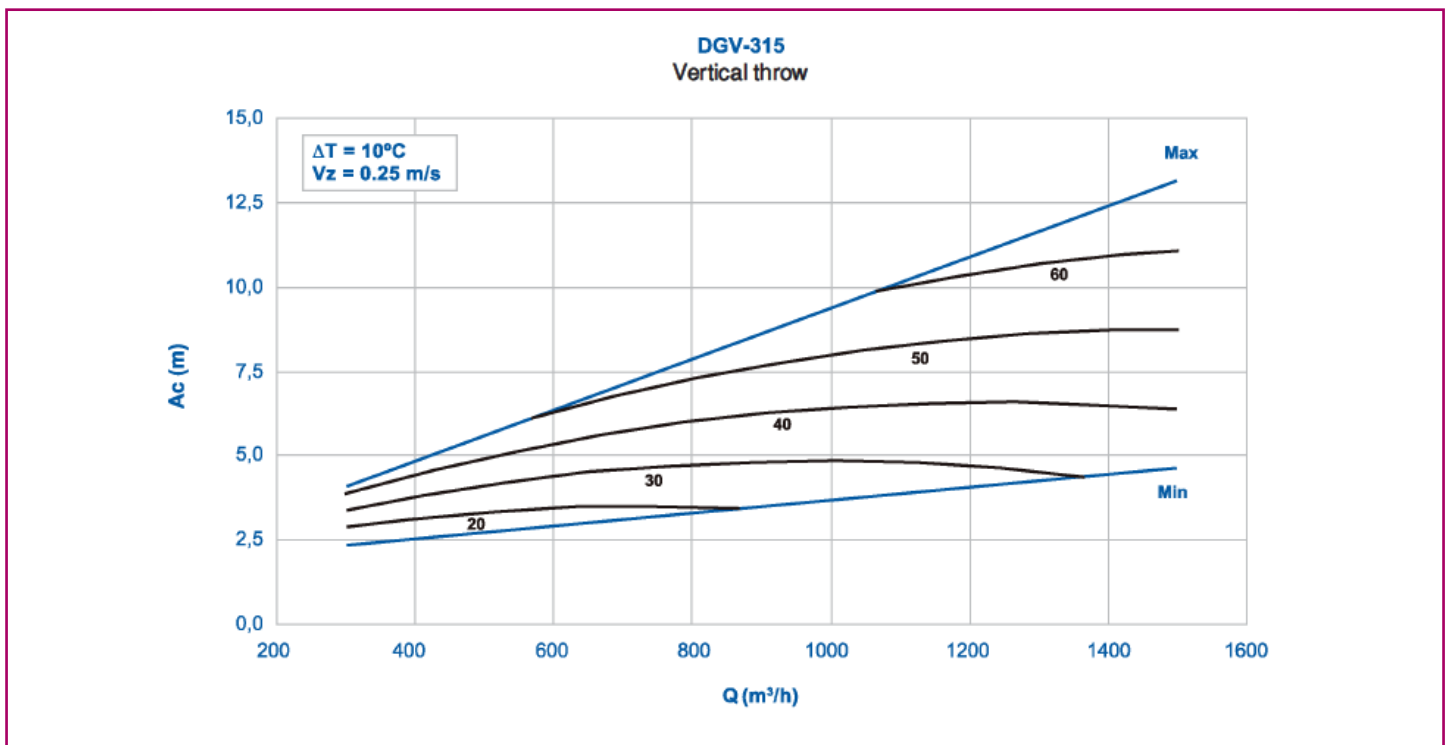
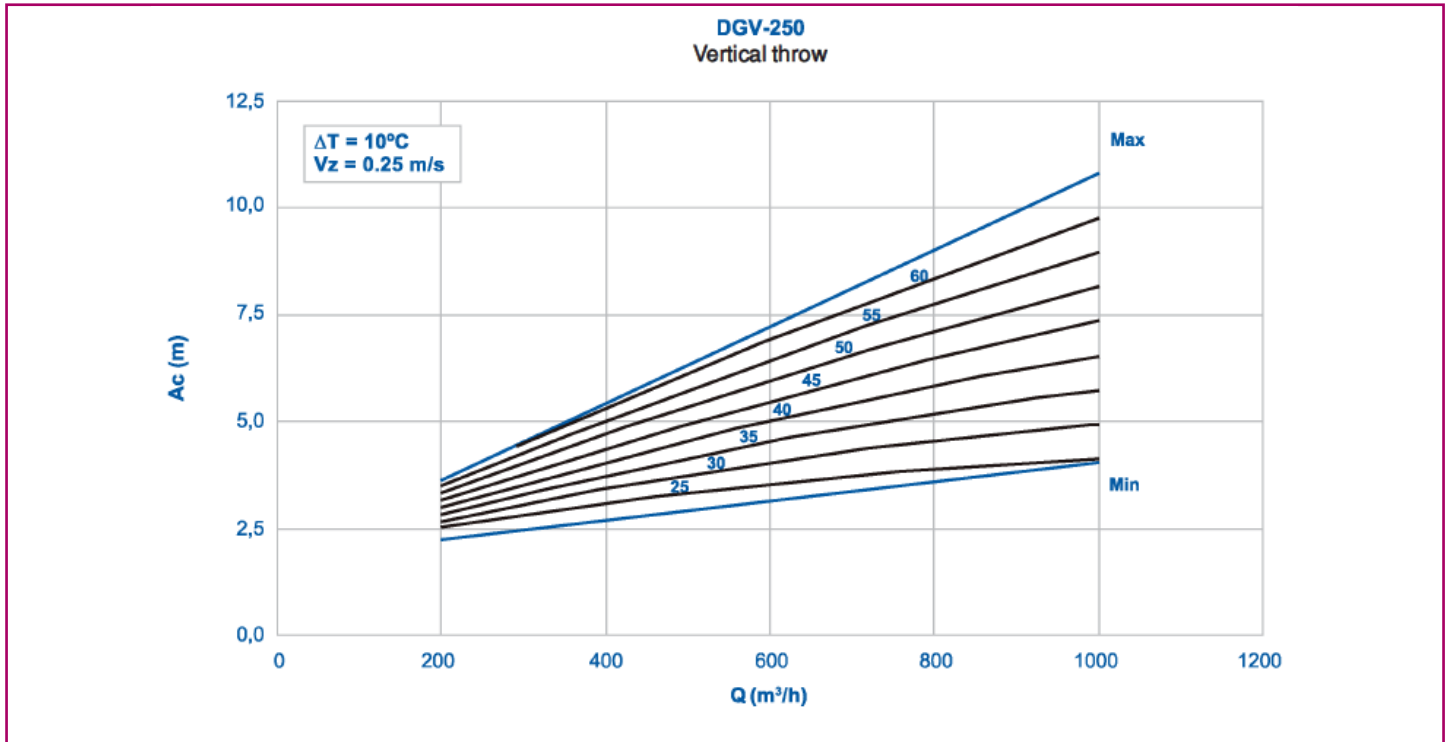

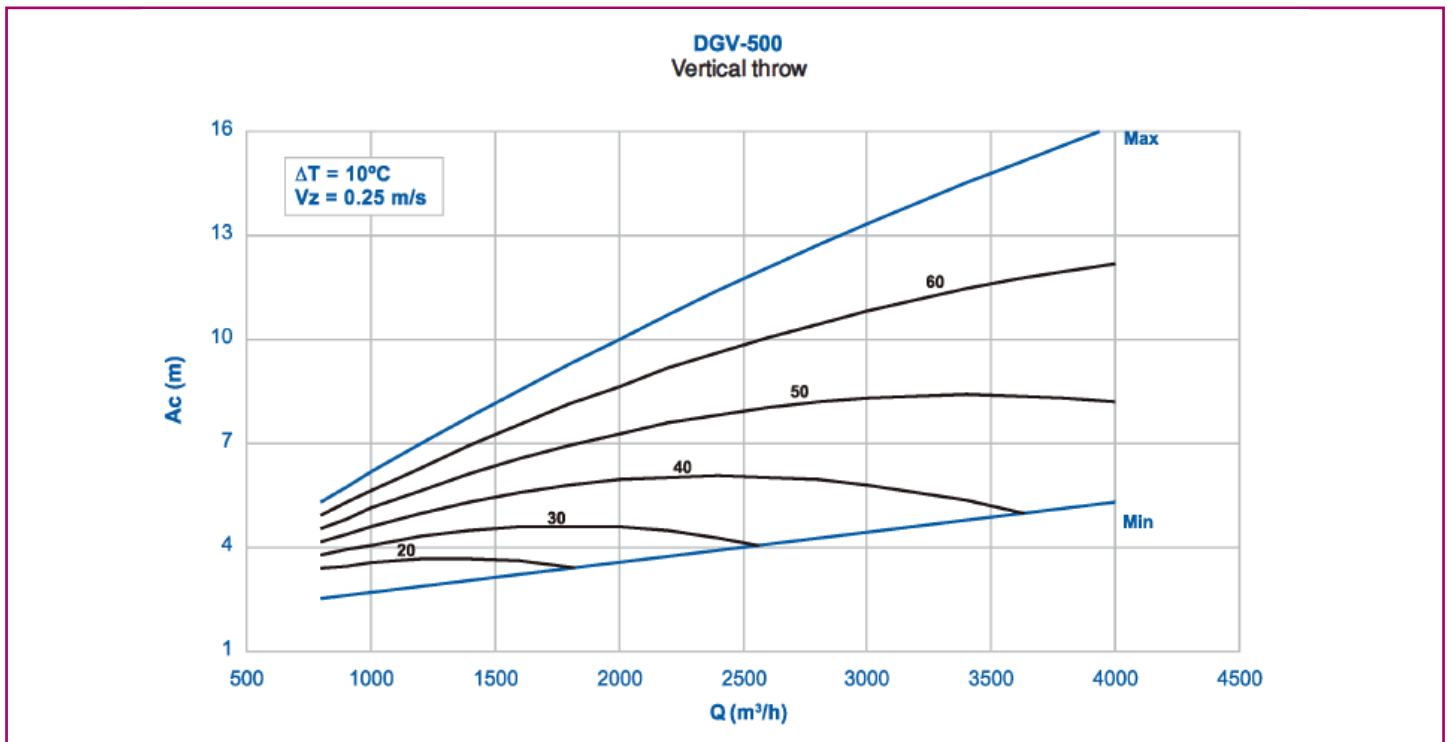
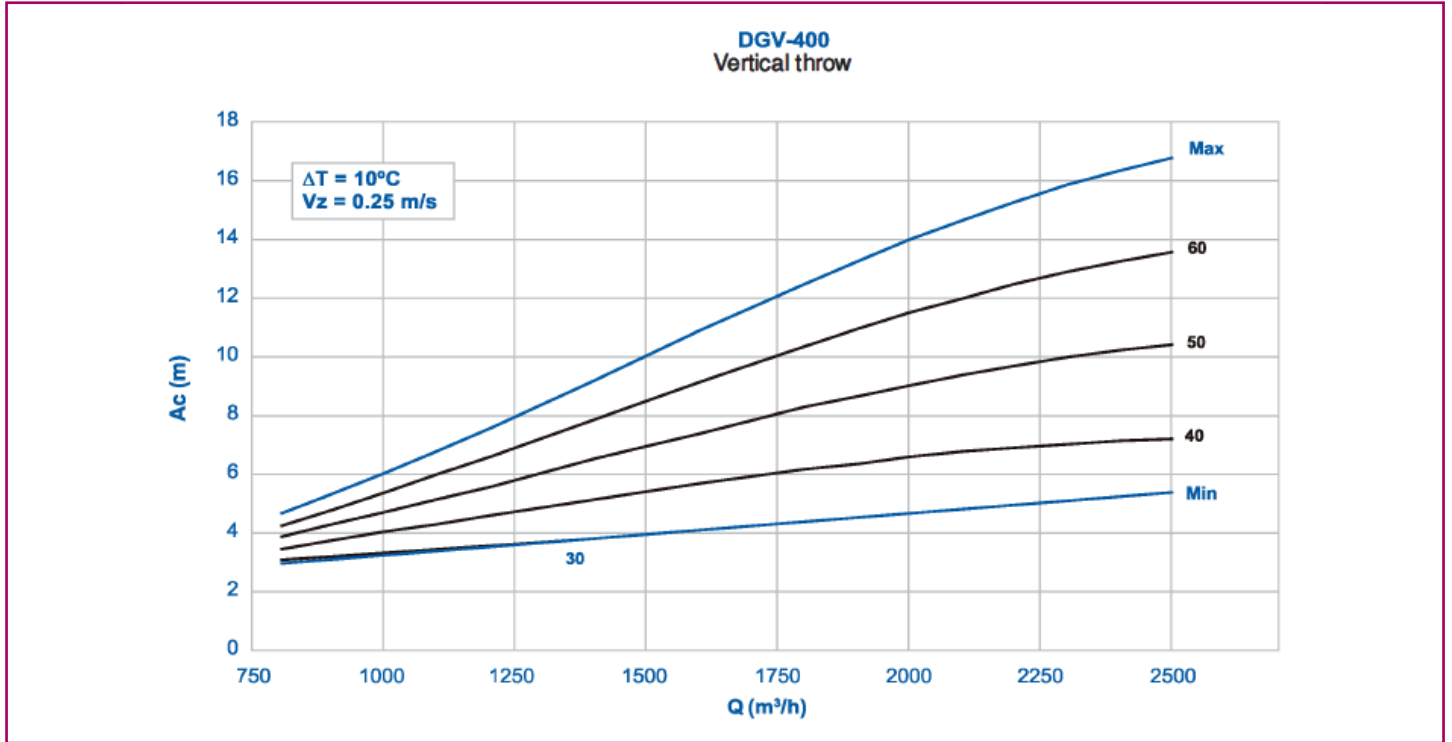

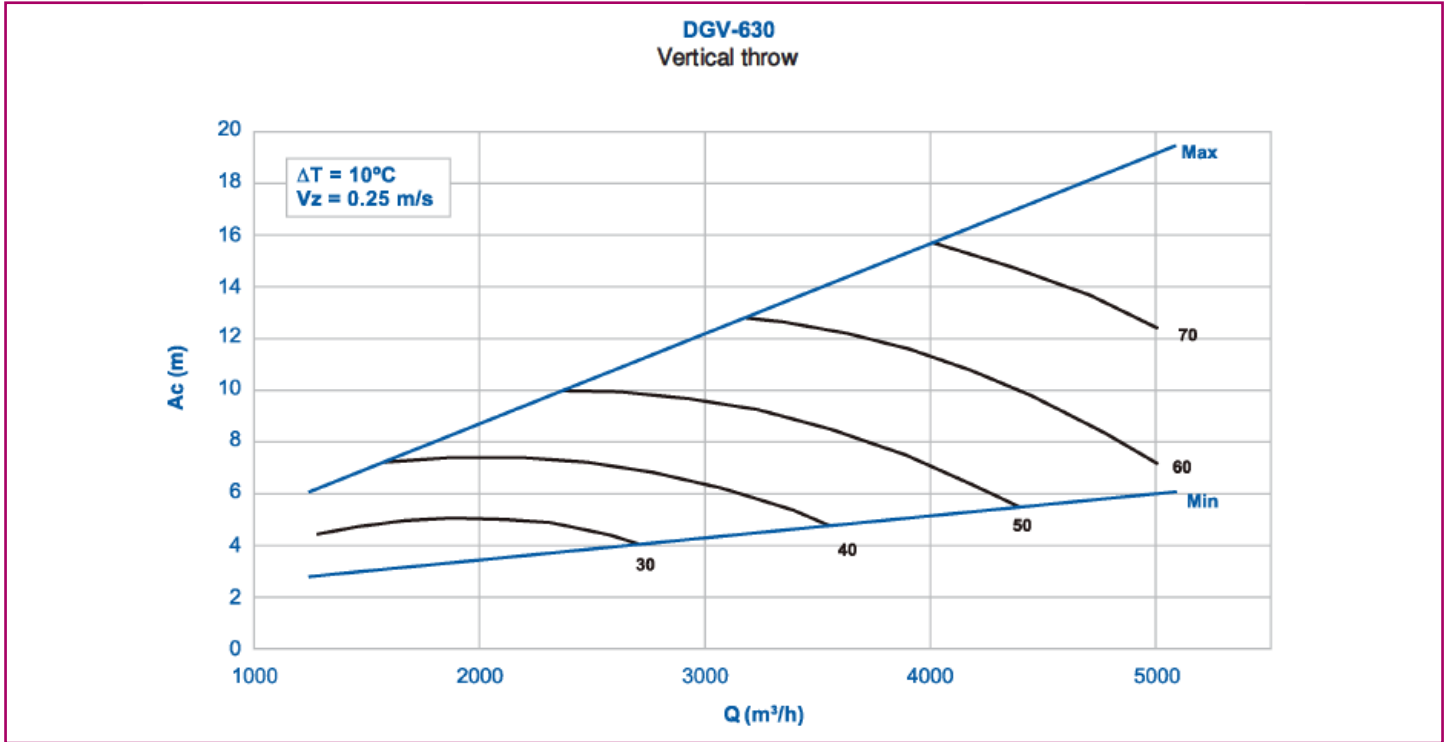

Where  $A_c$  is the vertical throw over the floor. The stroke (in mm) of the diffuser disc required to obtain the specified throw is shown on the curves.

The minimum and maximum values are the limits between which the throw can be changed.

## Selection charts to determine the factor, $C_a$ (minimum distance between diffusers)

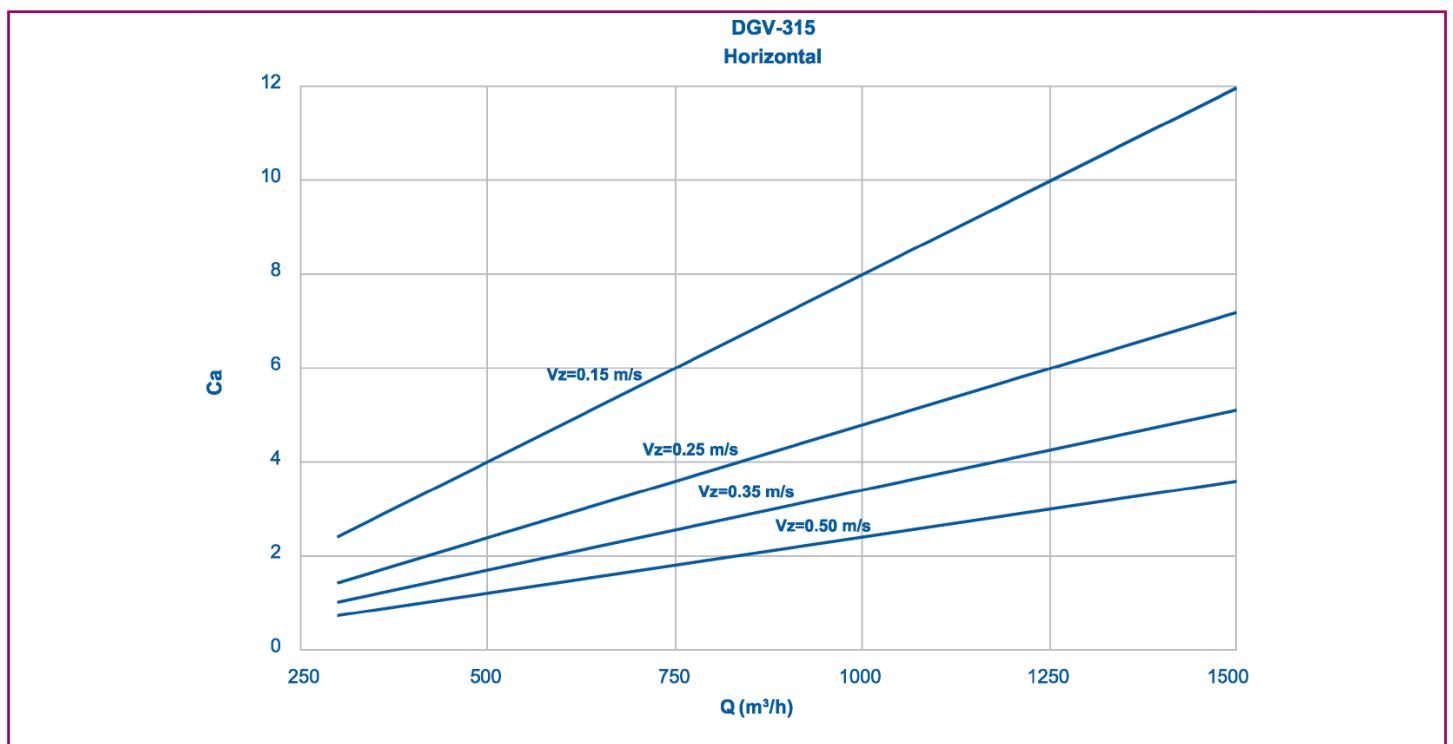
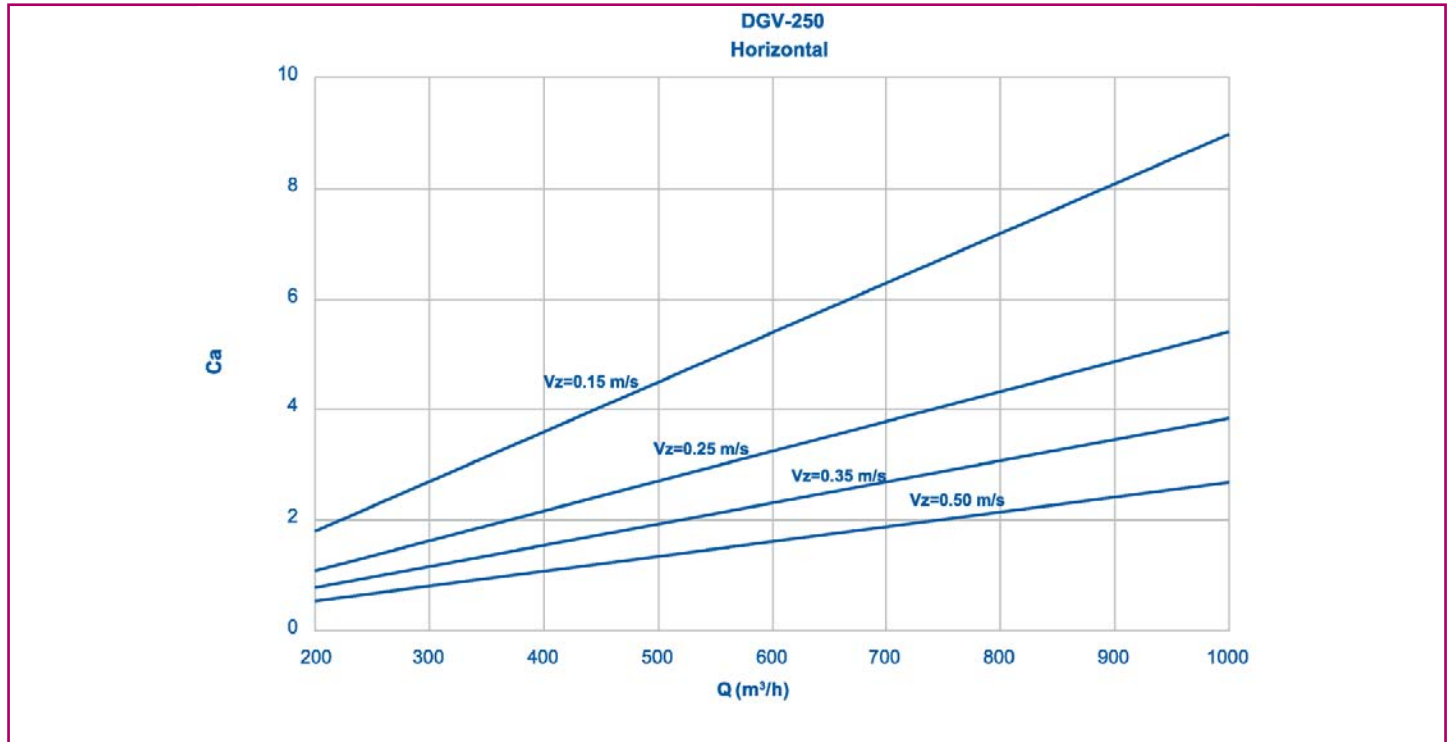

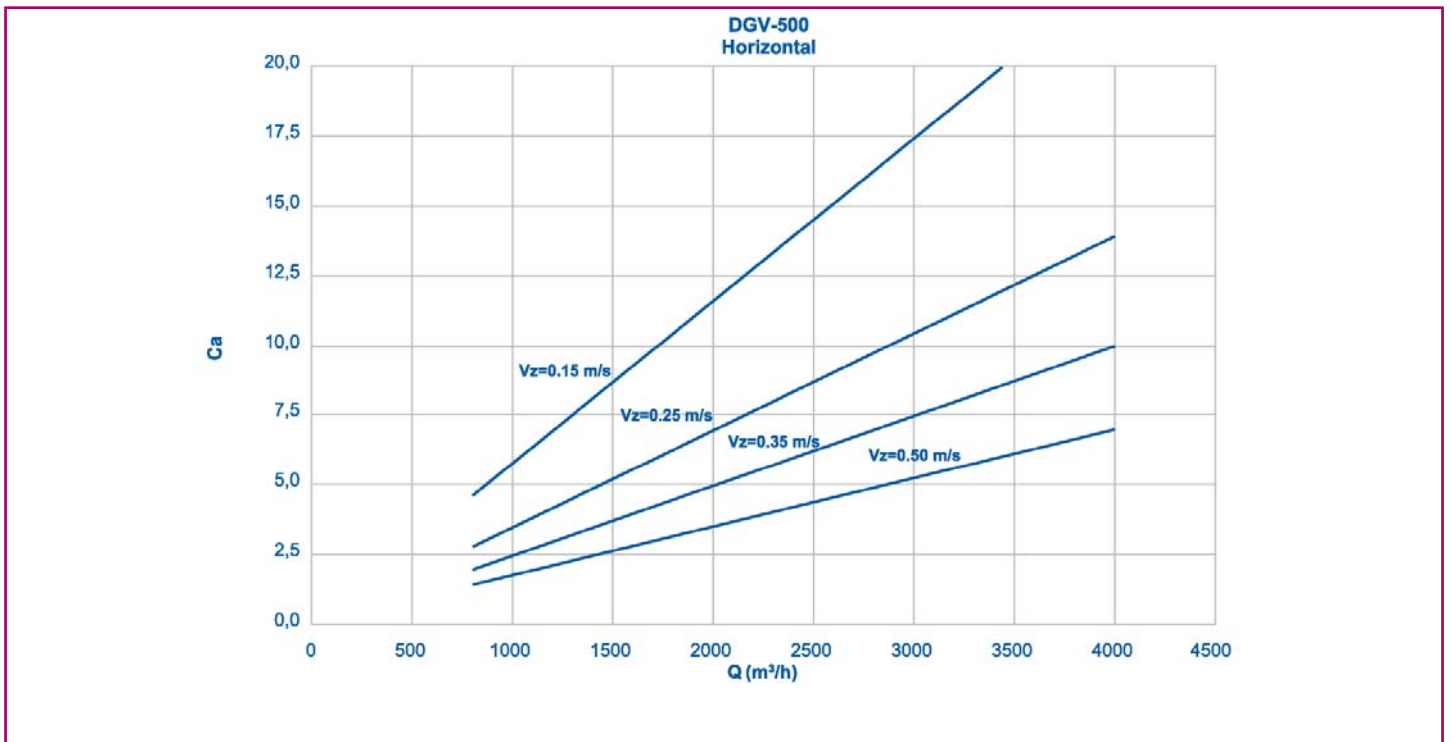
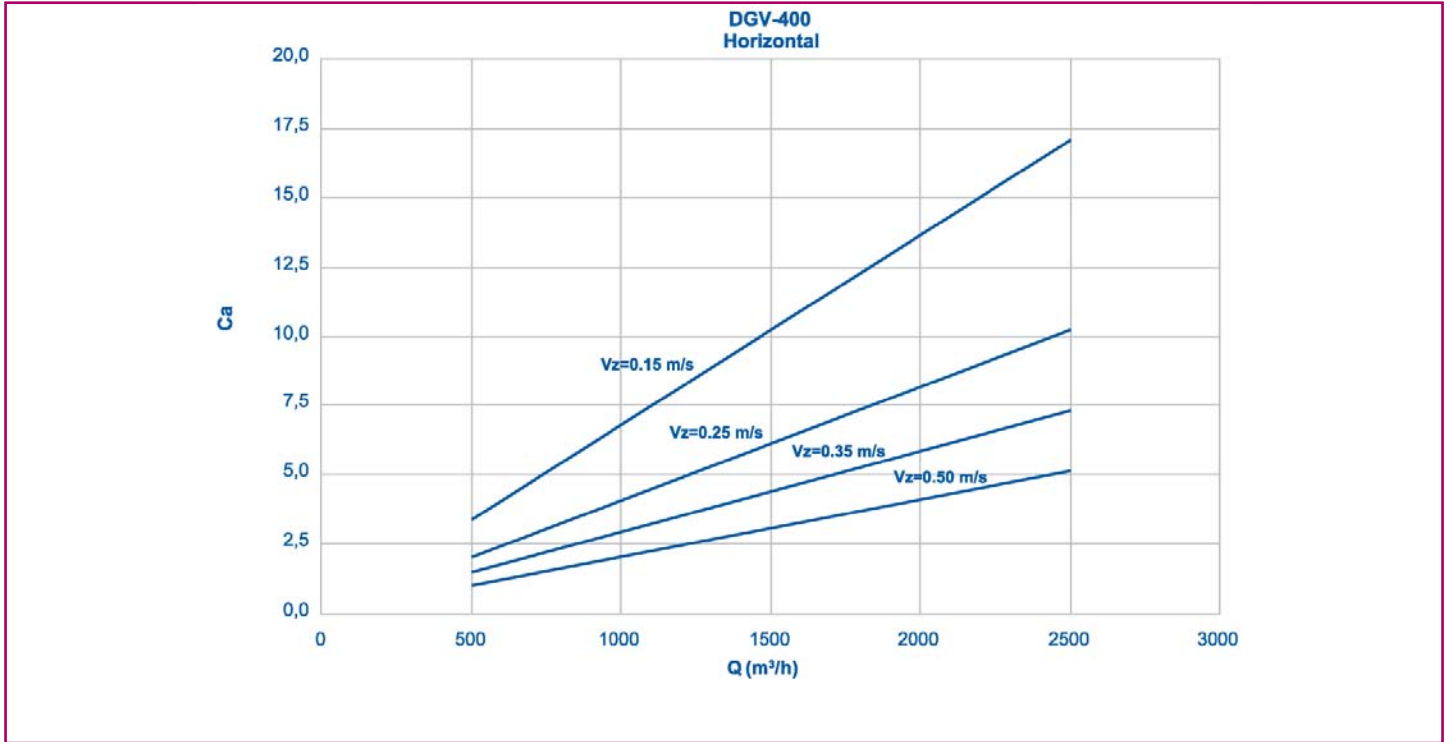



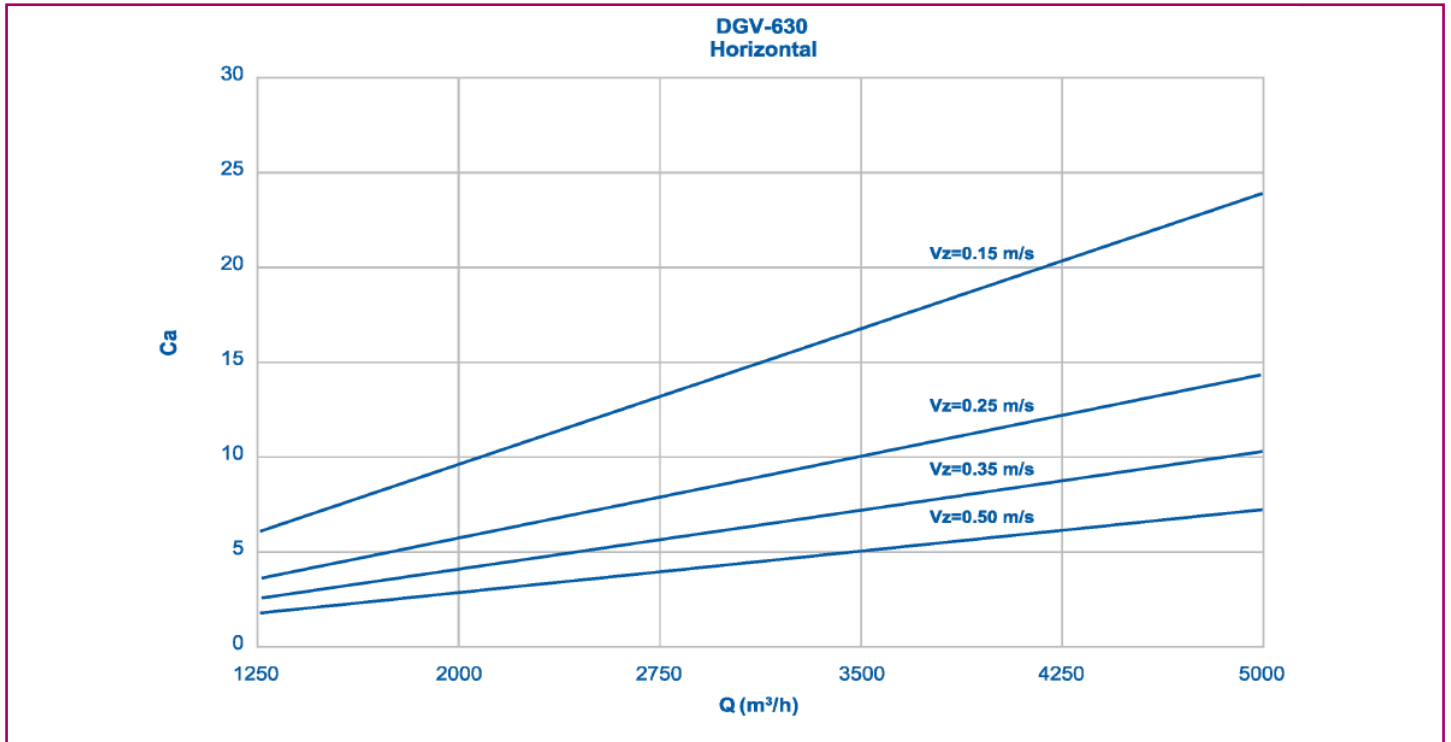

### Motor-driven operation

The motor-driven operation system should be determined for each specific case. Please contact our Technical Department to carry out the respective study.

**THIS CATALOGUE IS INTELLECTUAL PROPERTY.**

Reproduction, either partial or total, by any means, including electronic, is prohibited without prior written authorisation from KOOLAIR, S.A.



# KOOLAIR

**KOOLAIR, S.A.**

Calle Urano, 26

Poligono industrial nº 2 – La Fuensanta

28936 Móstoles - Madrid - (España)

Tel: +34 91 645 00 33

Fax: +34 91 645 69 62

e-mail: [info@koolair.com](mailto:info@koolair.com)

[www.koolair.com](http://www.koolair.com)